

Proceedings of the
Danish Institute at Athens · I

Edited by Søren Dietz



© Copyright The Danish Institute at Athens, Athens 1995

The publication was sponsored by:
Consul General Gösta Enboms Foundation.
The Danish Research Council for the Humanities.
Konsul George Jorck og Hustru Emma Jorck's Fond.

Proceedings of the Danish Institute at Athens

General Editor: *Søren Dietz*
Graphic design and Production by: *Freddy Pedersen*

Printed in Denmark on permanent paper

ISBN 87 7288 721 4

Distributed by
AARHUS UNIVERSITY PRESS
University of Aarhus
DK-8000 Århus C
Fax (+45) 8619 8433

73 Lime Walk
Headington, Oxford OX3 7AD
Fax (+44) 865 750 079

Box 511
Oakville, Conn. 06779
Fax (+1) 203 945 94 9468

The cover illustration depicts a Bronze Statuette
of a Horse found at the Argive Heraion. NM 13943.
Drawing by Niels Levinsen. See p. 55, Fig. 19.

The Early Sanctuary of the Argive Heraion and its External Relations (8th.– Early 6th. Cent. BC.)

THE GREEK GEOMETRIC BRONZES

Ingrid Strøm

Abstract

The Geometric bronzes from the Argive Heraion and Argos, primarily from the sanctuaries, are compared to clarify relations between the two sites.

The bronze statuettes, quadrupeds and birds, from the Heraion are of Thessalian, Central Greek, Peloponnesian, primarily Arcadian, or local origin, the local quadrupeds being influenced by Arcadia. Of three known figures from Argos, a local warrior shows Laconian relations and a Central Greek bird differs from the Heraion types. The personal ornaments from the Heraion come from the same regions as well as Macedonia, the ornaments found at Argos from Arcadia, in addition to insular fibulae of types unknown at the Heraion. EPC vases and pins local to the Corinthia and the Argive Heraion (Geometric I C and III) are absent in Argos, the Argos “Kalotten-schale” and pins of Geometric XVIII A and XX at the Heraion.

The EG/MG bronzes (in Argos known only from tombs) differ at the two sites. Although both show connections with Arcadia, the LG Heraion is more closely related to Corinthia than to Argos, which has ties to Laconia.

Bronze tripods are unknown at Argos, but develop at the Heraion from MG II to Subgeometric, presumably locally produced by itinerant artisans, connected especially with the eastern Mainland regions.

According to the evidence of the bronzes (the only Geometric material adequately published), the Argive Heraion developed slowly from around 900 BC or earlier, independently of Argos. From MG II onwards, inhabitants of Argos increasingly visited the Heraion, but never outnumbered other Mainland Greek visitors; apparently they were mainly women, not influential and wealthy men. The LGII/Subgeometric votive bronzes from the neighbouring

small Hera sanctuary are similar to those of the Heraion; the contemporary deposits in the surrounding Mycenaean tombs, however, are only similar in part, perhaps because they were made primarily by male visitors.

A. Introduction

In an earlier paper on the same general subject I discussed the monumental architecture of the Early Argive Heraion from the late 8th to the early 6th Cent. BC, comparing it with that of contemporary Argos. I reached the conclusion that the building program of the sanctuary seemed to be organized separately from the contemporary settlement.¹ However, the architectural remains at both sites are too scarce for definite results concerning the relations between sanctuary and settlement during this period of early urban development and the study material needs to be expanded.

Our basic information of the period in question is archaeological, but since only a small selection of the total pottery and terracotta finds from the Argive Heraion are published,² I have chosen the bronzes as supplementary study material. Those from the Argive Heraion are, to a large extent, published³ and those from Argos are well-known⁴ and they may inform us of interrelations between the two sites as well as of possible differences regarding production centres and foreign contacts, economic and cultural aspects.

The bronzes from the Argive Heraion will form the fundamental basis of my studies which after a few introductory sections will be divided chronologically. This paper examines the Greek Geometric bronzes.⁵

The studies of each main group of bronzes from the Argive Heraion will be followed first by those of the two nearby votive deposits of Late Geometric/Early Archaic date, the small Hera sanctuary close to the Early Mycenaean tholos tomb and the offerings in the Mycenaean chamber tombs in the surrounding hills,⁶ and second by those from Argos, primarily the bronze votives from the sanctuaries.⁷

There may have been several bronze workshops in the Argolid during the Geometric and Early Archaic Periods and there are, of course, bronze votives at other sanctuaries in the region as well.⁸ However, since the principal purpose of my studies is a deeper understanding of the relations between the Argive Heraion and the settlement of Argos at the time of the emergent city-states, I shall confine myself chiefly to the bronzes from the two sites.

B. Distribution of Finds in the Argive Heraion

The bronzes from the Argive Heraion, known today to number about 3,000, are nearly all in the National Museum of Athens. The greater part of the bronzes come from Ch. Waldstein's excavations, supplemented by smaller collections from the investigations of Blegen and Caskey and Amandry.⁹ Very few bronzes in other museums seem to have the Argive Heraion as their provenance.¹⁰ The present whereabouts of the bronzes found before Waldstein's excavations are not known to me. This applies, e.g., to a lion figure discovered in 1836 by General Gordon on the site of the Classical Temple, to some bronzes, not further specified, from General Kallergis' excavations in the 1840's, as well as to the finds of Rangabé and Bursian in 1854 east of the Classical Temple. They comprised: "... mehrere verbrannte und verrostete Fragmente von Bronze-geräthen wie Nägel, Nadeln, Ringe, Stücke, wahrscheinlich von Opferschalen, und unter anderen einen kleinen Stierkopf ... der als Weihgeschenk an der Wand angenagelt zu sein scheint."¹¹

There are bronzes of Mycenaean as

well as of Classical or later date,¹² but the majority are Geometric or Archaic, the periods which concern us here. The bronzes were found all over the area of the Classical sanctuary as well as immediately outside.¹³ The three primary in situ find spots are the following:

I. The Old Temple Terrace, where the monumental bronzes appear to dominate.¹⁴

II. The hill above with its votives of mainly miniature character.¹⁵

III. The area east of the Classical Temple, the supposed site of the Altar, where phialai and smaller votives were mingled with fragments of monumental bronzes.¹⁶

About 20 bronzes were found at the Northeast Stoa and the area east of that stoa. As their find spots thus border the Altar area to the north, it is possible that they were lying close to their original position.¹⁷ The same observation may apply to the bronzes stated to have come from the foundations of the Second Temple, bordering the Altar area to the west.¹⁸

Most of the votive bronzes from the sanctuary were found in a secondary position. The large fill west of the Classical Temple was presumably brought mainly from the Altar area.

However, the fill also contained building material belonging to the Archaic Temple and its Terrace, and therefore possibly other objects as well,¹⁹ which may have been thrown in after the destruction of the Temple in 423 BC. The bronzes of this fill²⁰ were generally of the same types as the numerous bronzes from the West Building, which comprised mirrors, phialai, miniature vases, personal ornaments such as rings, fibulae, pins etc. as well as a few figured bronzes²¹, and which presumably are also mainly altar refuse. The deposit of the same general character, found at the Eastern Retaining Wall, is identified as an altar discard from around 550 BC.²²

The many bronzes from the Back of South Stoa²³ and the Southern Slope²⁴ are of a similar appearance, although the latter find spot, in particular, yielded a considerable proportion of the Archaic bronze figures known from the Argive Heraion. As



Fig. 1 (A - B). Athens. National Museum. NM 14004. Casting waste with lion's paw. AH 2829. Museum photos.

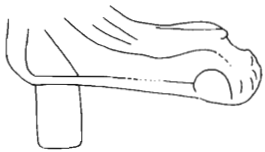

Fig. 2. Athens. National Museum. NM 14004. Casting waste with lion's paw. AH 2829. Drawing of detail.

both areas were situated outside the Archaic sanctuary,²⁵ the bronzes may chiefly represent votives fallen down from above.

The bronzes from the Northwest Building are few, consisting of one seal ring, four Geometric or Archaic bronze figures, and one fragment of an Archaic support with a lion's paw; it thus differs in character from the above-mentioned large discards from the altar with their many miniature votives.²⁶ As regards the North Stoa I have no information at all of any bronze votives.²⁷ This remarkable lacuna may perhaps indicate that the early bronze votives placed in the Altar area did not extend west of the Ramp which led to the Old Temple Terrace between the North and the Northeast Stoi.²⁸ In fact, the original placing of the Geometric/Archaic bronzes was apparently limited to the three primary find spots, the Old Temple Terrace, the Upper Hill, and the Altar area. The last-mentioned site would now and then be cleared of its accumulation of votives which were then used as fill wherever a levelling of the slope was required for building activity.

C. Technology

Like several other Greek sanctuaries,²⁹ the Argive Heraion also gives evidence of local bronze production. The faulty or unfinished bronze objects and the repaired

bronzes do not necessarily imply manufacture nearby.³⁰ Nor does a small terracotta mould for casting miniature ornaments; it may have served for votives in e.g. gold or silver.³¹ However, at the Argive Heraion we have examples of round copper or bronze ingots, the raw material for bronze working³²; of shapeless pieces of spill, the superfluous material from the melting process³³; as well as of bronze scraps collected for remelting.³⁴

In all, these finds indicate the existence of bronze working in the immediate vicinity of the sanctuary. The exact find spots are in most cases unknown and although some may point to a position to the west or south of the original sanctuary³⁵, the workshops cannot be located today.

Further proof of bronze working is provided by miscasts,³⁶ in particular a casting waste with a lion's paw, measuring 15.4 cm. in length. On the upper side of the paw is a deep crack, possibly the reason for rejecting this unidentified bronze object, which may have been meant as part of a vase or an implement, AH 2829 (NM 14004)(Figs. 1 - 2). Preserved are the funnel with its filling of bronze and the waste of the pouring cup with a jet (1.7 cm. long). The fragmentary object consisted of a "bowl-like" part, to which is attached the lion's paw (7 cm. in length). On one side of the "bowl-like" part, near the paw, are two raised curved parts. On the other

side is a series of irregular, semicircular cavities. On the underside of the paw a cylindrical dowel is preserved. Except for the lion's paw, the surface is rough and the "bowl-like" part shows several cracks. The inner surface of the paw is blurred and the toes are damaged. Nevertheless, the rendering of detail of the outside of the paw is precise; three of its four toes are distinguishable and there is a raised line along the heel and sole, giving it a sandal-like appearance. The schematic rendering of the details of the lion's paw indicates a date in the Early Archaic Period.³⁷

Often, the centre of production of the Geometric and Early Archaic Argive bronze votives is assigned to Argos,³⁸ a settlement which definitely yielded bronze objects of specific types and presumably of local manufacture as well as giving evidence of very early metal working.³⁹ On the other hand, the so-called Argive Geometric figure style was first distinguished on bronzes found at the Argive Heraion⁴⁰. Since a local bronze production has been recognized here, the origin of its local bronze votives should be restudied. For every group of Greek bronzes, I shall try to determine their most probable place of origin, taking into account the criteria of style, provenance as well as, to a certain degree, technique.⁴¹

Greek Geometric Bronzes

D. Tripods

The Argive Heraion

Although iron was not infrequently used at the Argive Heraion,⁴² there are no recorded finds of iron tripods here.⁴³ The Geometric tripods, the earliest known votives of monumental size, are all of bronze.⁴⁴ Only four fragments have an exact provenance, two of which indicate an original position near the Altar and on the Old Temple Terrace, respectively.⁴⁵

There is no sign of any tripod in the Argive Heraion belonging to the initial phase of Geometric production.⁴⁶ Nevertheless, we have representatives of all four

main groups, into which the tripods from the largest known collection, that of Olympia, are usually classified: Solid Cast Tripods (Dreifüsse mit massiv geformten Beinen und Henkeln), Relief Tripods (Relifizierte Dreifüsse), Tripods with Fanned Grooves (Gratbein Dreifüsse), and Hammered Tripods (Gehämmerte Dreifüsse). The four groups seem in general to represent a relative chronological development, in most cases with a technical improvement in relation to the preceding group and at the same time gradually increasing in actual as well as proportional height. Except for the hammered cauldrons, the three first-mentioned groups are made entirely of cast bronze, the hammered tripods are essentially of hammered bronze plate.⁴⁷ In size, the Olympia tripods increased from a height of about 60 - 70 cm., with a cauldron of almost the same diameter, for the earliest known examples, to an estimated height of about 3.50 m., handles included, for the largest hammered tripods, the cauldron diameter of which measured about half the height of their legs.⁴⁸

Most tripod fragments from the Argive Heraion are so small that neither their original height nor their proportions can be determined today. A few were definitely of miniature size, though of normal tripod types.⁴⁹ The specific miniature tripods, which were either cast in one piece or formed of sheet bronze and which are known from Olympia as well as from other sanctuaries,⁵⁰ do not appear to be represented here.

Solid Cast Tripods

The Solid Cast Tripods have solid cast legs as well as handles. The Olympia tripod legs develop from an early polygonal form to one roughly rectangular in section, the latest examples of which have a hollow back. The handles have a raised pattern which seems to imitate ropes. In some cases, the whole cauldron or parts of all its separate elements are preserved, giving us a good idea of the general appearance of this class of tripods.⁵¹

Willemsen divided the Solid Cast Tri-



Fig. 3 (A - B). Athens. National Museum. NM 16551. Solid Cast Tripod handle figure. Argive Heraion. Photo American School of Classical Studies, Athens.

pods from Olympia into several sub-
 groups, basing his classification on differ-
 ences in the sections and ornamentation
 of the handles.⁵² In my opinion, it seems
 possible to divide Willemsen's classes of
 Solid Cast Tripod handles in two main
 subgroups. Willemsen's "Strickhenkeln",
 "Kerbenhenkeln" and "Wulsthenkeln"
 have the same general characteristics. The
 handles show a rounded triangular section,
 as the ropes of the raised pattern are
 placed so close together that those in
 Willemsen's first two classes give the im-
 pression of a herring-bone pattern, in the
 last of a wavy surface, the ropes having
 been replaced by simple relief lines.⁵³ Ap-
 plied ornamentation of false spirals or vo-
 lutes sometimes decorate the handles or
 the handle straps.⁵⁴ The handle figures are
 soldered to the tripods; horses may be
 placed inside the handles on the handle
 straps, while horses, bulls' heads or birds -



the two last-mentioned types recalling the
 decoration of the Cypriot rod tripods -
 may decorate the top of the handles.⁵⁵ We
 have a few examples of whole tripods or
 of cauldron fragments with both handles
 and legs attached, showing a vertical rope
 pattern as decoration of the leg, the upper
 part of which might also have applied or-
 naments like those of the handles and
 handle straps.⁵⁶ Solid Cast Tripods with
 the above characteristics, I shall call Sub-
 group I, to which subgroup belong the
 early tripods of polygonal section.⁵⁷

Willemsen's remaining Solid Cast han-
 dle groups are more varied and do not all
 appear to be closely related. However, his
 "Doppelkranzhenkeln" and "Schnurrhen-
 keln" as well as some examples of his very
 heterogeneous groups of "Kranzhenkeln"
 and "Treppenhenkeln" correspond as to
 technical and decorative details. The han-
 dles have a pointed triangular section and



Fig. 4. Athens. National Museum. NM 20629 B. Solid Cast Tripod. fragment of leg. AH 2220. Museum photo.

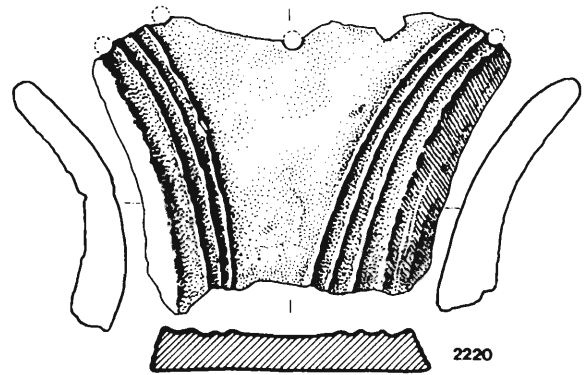

Fig. 5. Athens. National Museum. NM 20629 B. Solid Cast Tripod. Fragment of leg. AH 2220. Drawing.

their rope imitations or relief lines are distinctly separated by plain parts.⁵⁸ Applied ornamentation is rare and spirals apparently absent; in Olympia there is one example with applied volutes on the handle strap.⁵⁹ The handle figures which may be either soldered or nailed to the tripod are always placed on top of the handle, and consist chiefly of horses and an occasional horse leader. There seem to be no examples of bulls' heads or birds.⁶⁰ Again we have a few tripods with both handles and legs attached to the cauldron; the legs lack the characteristics of the former subgroup, and appear to be decorated with vertical relief lines only.⁶¹ I shall call the tripods with the above characteristics Subgroup II.⁶²

The manufacture of the tripods which I have called Subgroup I apparently started earlier than Subgroup II, but as shown by Maass both continued until the transitional phase to the Relief Tripods.⁶³ During the later phase of the production of Solid Cast Tripods there thus seem to be two main contemporaneous classes.

Not all Solid Cast Tripod fragments at Olympia can be connected with either of the two subgroups and they do not in all details conform with tripod collections at other sites.⁶⁴ However, the Argive Heraion fragments are closely related to the Olympia examples.

At the Argive Heraion, the Solid Cast Tripods are represented by one handle fig-

ure and two fragments of legs.

NM 16551 (Fig. 3) is a solid cast male statuette, representing a nude horse leader cast in one piece with a flat handle plate with two large, vertically placed nail holes. Including the handle plate, the figure measures 10.8 cm. in height. The lower part of the man's right arm is broken off, the left hand ends in a point, but is intact. There is no trace of the penis which must be broken off. The figure is long and slender with a pinched-in waist and a rather loose, curving outline. There is little modelling and there does not appear to be any intentional engraving of the details of the figure. The man is standing with his legs apart, his right arm stretched forward and the left one bent downwards, the hand barely indicated. His neck is long and his head extremely small; on top of it is a pointed, vertical depression. While the line of the neck is vertical, that of the forehead is oblique. He has short hair, the eye hollows are two small round depressions and there is no ear rendering. The only feature which is distinctly marked is the mouth, a large horizontal opening that gives the impression of protruding lips.⁶⁵

Willemsen observed that the vertically placed nail holes were characteristic of the few known handles of the Solid Cast Tripods with nailed figures and referred to an exactly corresponding handle fragment of a "Schnurrhenkel" from Olympia, of a



Fig. 6. (A - C). Athens. National Museum. NM 14008. Solid Cast Tripod. Fragment of leg. AH 2218. (A - B) Photos Deutsches Archäologisches Institut, Athen. Neg. nos. 72/355 and 72/356. (C) Museum photo.

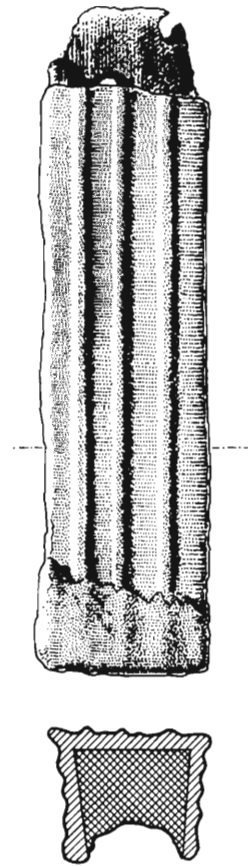

fig. 7. Athens. National Museum. NM 14008. Solid Cast Tripod. Fragment of leg. AH 2218. Drawing and section.

comparatively late date within the group of Solid Cast Tripods⁶⁶

AH 2220 (NM 20629 B) (Figs. 4 - 5) forms the upper termination of a tripod leg, where it bends round the cauldron. It is decorated with vertical relief lines. The fragment measures 10.2 x 7.7 cm. Although the actual upper edge is not preserved, there are remains of the upper central nail hole for fastening the leg to the cauldron as well as parts of three more nail holes. The plate is thin here, measuring only 0.4 cm. as compared with 1.1 cm. at the lower break.⁶⁷

AH 2220 has several close counterparts among the Olympia tripod legs, two of which are still connected with their handles of Willemsen's "Doppelkranzhenkeln" and "Schnurrhenkeln" types.⁶⁸

AH 2218 (NM 14008) (Figs. 6 - 7)

forms the lower part of a tripod leg with almost rectangular section, but hollowed out at the back, about 1.5 cm. in depth. The fragment which is broken above measures 18.1 cm. in height. It is very irregularly cast, varying in width from 4.6 cm. above to 4.9 cm. below and in depth from 3.7 cm. above to 3.3 cm. below. It has an extra coating of bronze at the bottom of the leg, due to an overflowing of liquid bronze during the casting process. Like AH 2220, the leg is decorated with vertical relief lines only; they are rendered on all three sides, but at the area of coating only in front.⁶⁹

The tripod leg seems to be most closely related to the same subgroup as AH 2220. Judging from its hollow back, it should be placed in a late phase of the Solid Cast Tripods, but according to

Maass' definition before the actual transition to the Relief Tripods.⁷⁰

The three Argive Heraion examples of Solid Cast Tripods all find their closest counterparts among the Olympia tripods which I have classified as Subgroup II, whereas they do not show any of the characteristics of Subgroup I.

Relief Tripods.

The Relief Tripods, named after the decoration of their legs, signify a technical improvement over the preceding group of cast tripods, their legs forming a hollow rectangle like the letter π .⁷¹ On technical criteria, Maass divided the Relief Tripods at Olympia into two main subgroups, the Application Tripods and the Matrice Tripods.⁷²

The decoration of the legs of the Application Tripods was applied to the wax mould of the whole leg, false spirals and multiple semicircles being the favourite ornaments.⁷³ Maass assigned handles with an upper open part as well as rib handles to the Application Tripods. The former handles have either two rows of small and rather closely set zigzags or one row may be replaced by spirals. Out of context these handles, especially the rib handles, are difficult to distinguish from those of the Matrice Tripods; however, the soldered handle figures, placed on top of the rim, rather thick-set horses, in one case a lion and in a few others a bird, are similar to those of the above-mentioned open work handles.⁷⁴

For the Matrice Tripods, separate matrices were used for each of the three sides of the leg, which were then joined in the mould. Unlike the Application Tripods, they have no spiral ornamentation or rows of semicircles. Their chief decorative repertory comprises zigzags and a dog-tooth pattern, combined in the more spectacular pieces with an upper and lower metope which may have either a figure motif or an ornament: a rosette, a wheel or a Maltese cross.⁷⁵ Some handles are seen in connection with either legs or handle straps with zigzag ornamentation in matrice

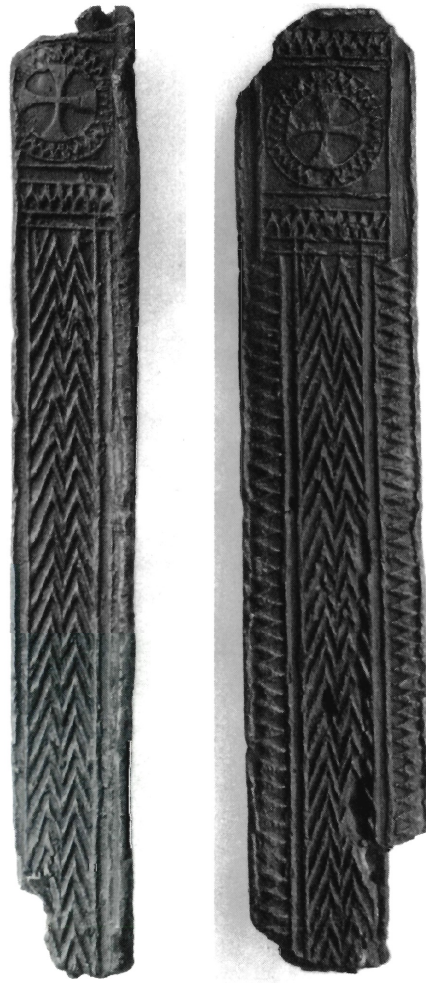

Fig. 8. (A - B). Athens. National Museum. NM 14007. Relief Tripod. Fragment of leg. AH 2221. Photos Deutsches Archäologisches Institut, Athen. Neg. nos. 72/682 and 72/683.

technique and thus definitely belong to this subgroup.⁷⁶ The handles are either partially open work handles or rib handles. The open work part of the former usually shows rather large, elegant zigzags, while the solid lower part is divided by double, sometimes triple lines, distinctly separated by plain parts. Found out of context, the handles, especially the rib type, can be difficult to classify, but both types of the Matrice Tripods have similar handle figures of a horse and often a horse leader, placed on top of the rim, the horses usually of a rather light appearance with a long trailing tail.⁷⁷

At the Argive Heraion, the Relief Tri-



Fig. 9.(A - B) Athens. National Museum. NM 20629 γ). Relief Tripod. Fragment of rib handle. AH 2222. Museum photo.

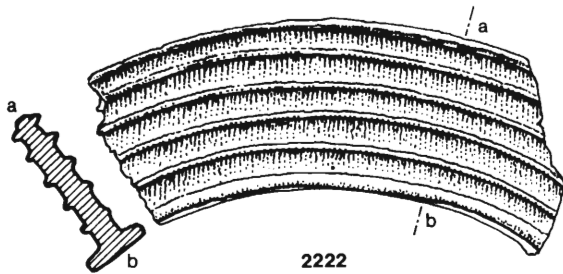

Fig. 10. Athens. National Museum. NM 20629 γ). Relief Tripod. Fragment of rib handle. AH 2222. Drawing and section.

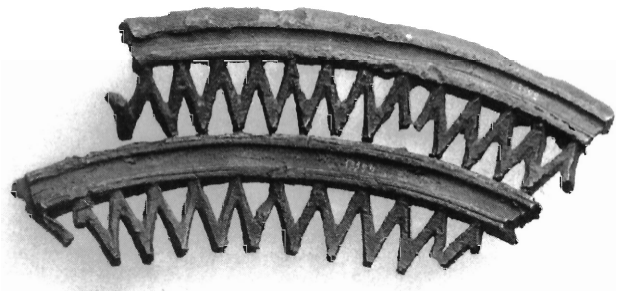

Fig. 11. Athens. National Museum. NM 13992. Relief Tripod. Two joining fragments of open work handle. AH 2223 - 2224. Photo Deutsches Archäologisches Institut. Neg. no. 72/357.

pod is represented by fragments of one tripod leg and three handles.

Most impressive is the fragmentary tripod leg AH 2221 (NM 14007) (Fig. 8). It is the upper part of a tripod leg which is broken above as well as below. The fragment measures 33 cm. in length, 6.1 cm. in width and 4.3 cm. in depth. Each side plate measures 3.7 cm. and the thickness of the plates varies between 0.6 and 0.7 cm. There is a heavy filling between the side pieces which are slightly bent towards each other. The filling measures in depth 2.3 cm. and in it are half embedded the two extant supports for fastening the cauldron. At the right-hand side of the front,

there is a deep fracture which seems to be secondary just above the lower break and there is some damage to the surface. The leg has the normal decoration of a Matrize Tripod: front and sides are decorated with a zigzag pattern, longitudinally framed at the front by a dog-tooth pattern. All three parts of the leg have an upper metope with a Maltese cross in a double circle and, in between the circles, a dog-tooth pattern, which also forms the upper and lower frame of the metope.⁷⁸ According to Maass, the same matrize was used for a tripod from Delphi, also with a heavy filling.⁷⁹ In several other instances, identical matrices were used for tripods in

the same sanctuary as well as for tripods from different sites.⁸⁰

AH 2222 (NM 20629 y) (Figs. 9 - 10) is a fragment of a rib handle with five ribs (including that of the rim). It measures 10.4 cm. in length and 3.7 cm. in width; its diameter is 23 cm. Found out of context, it cannot be definitely connected with either of the two subgroups.⁸¹

AH 2223 - 2224 (NM 13992) (Fig. 11) are two joining fragments of the open work part of one of the largest and most elegant handles of the Relief Tripods, 30 cm. in diameter. The fragments measure in length 11.1 and 11.3 cm. and in width 2.8 and 2.5 cm., respectively. The greatest thickness, at the rim, is 0.8 cm. The handle definitely forms part of the Matrice Tripods, its open zigzag sections of a very light appearance comparing well with the finest open work handles of this subgroup. A slight mutilation of the rim (AH 2223) suggests that originally one or more figures were soldered here, presumably a horse and possibly also a horse leader.⁸²

AH 2784 (NM 20817) (Figs 12 - 13) is a fragment of the lower solid part of a handle of the same type and belongs to the same subgroup. Only its lowest part is preserved; relief lines frame the plain part, double relief lines above and a single line below. At its front, there are still traces of the fastening of the handle strap and a small part of the fastening plate for the cauldron is preserved at the back. There is also a stump of one of the handle supports, measuring 0.6 cm. in diameter. The handle fragment measures 13.5 cm. in length; its outer diameter is ca. 29 cm.⁸³

For most fragments of the Relief Tripods at the Argive Heraion, a definite classification is possible: they belong to the Matrice Group. Only AH 2222, the fragment of a rib handle, cannot with certainty be connected with either of the two subgroups.

According to Maass, the two subgroups of the Relief Tripods form a continuous development from the earlier Application Tripods to the later Matrice Tripods over a transitional phase which combined technical and stylistic characteristics of both.

As pointed out by Maass, some tripods in application technique have the front of their legs decorated with zigzag or dog-tooth patterns, otherwise prevalent in the Matrice Tripods.⁸⁴ However, the same ornamentation, together with applied spirals, is observable also on one of the tripod legs from Delos, the section of which indicates a transitional phase from the Solid Cast Tripods.⁸⁵

Moreover, some Application Tripods definitely imitate the metope decoration of Matrice Tripods, while, on the other hand, one Matrice tripod from Olympia adopted the ornament of multiple semi-circles, characteristic of the Application Tripods; however, here it is used in a very restricted form, only as a horizontal border for the upper metope on the front of the leg.⁸⁶

As shown by Maass, at least three tripods from Olympia are of mixed style and technique. A supplementary plate was added to the front of their matrice legs at each side, in application technique and with the favoured spiral ornamentation of that style.⁸⁷ In my opinion, the above examples are indications of mutual influences and are to be interpreted as evidence for contemporaneity rather than as phases of development. It would be reasonable to view these tripods in the light of our evidence for Geometric bronze tripods having been cast close to the sanctuaries, where they were set up.⁸⁸ Most of the above examples come from Panhellenic sanctuaries and all the tripods of mixed style come from Olympia. Bronze workers from different Greek regions met at the Panhellenic Festivals, presumably working closely together and were thus exposed to influences from artisans with different traditions. The tripods of mixed style, in particular, actually seem to contradict Maass' theory, since the original tripod was in the suggested new style, the matrice technique, whereas the additions are in the suggested old-fashioned style, the application technique.

According to Maass, Application Tripods represent an intermediary phase between Solid Cast Tripods and Matrice

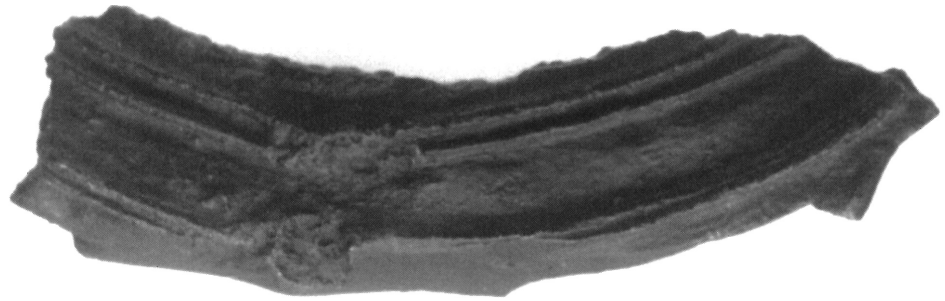

Fig. 12. Athens. National Museum. NM 20817. Relief Tripod. Fragment of open work handle. AH 2784. Museum photo.

Tripods, in stylistic as well as in technical respects. If this observation were correct, one should also expect to find a similar development of the tripods in local or regional sanctuaries. However, Application Tripods are not represented at the Argive Heraion at all. Although the tripods here are limited in number, we have fragments of seven, forming a continuous development from a comparatively late phase of Solid Cast Tripods to Matrice Tripods, but not one fragment of an Application Tripod.

Maass observed a transitional stage between Solid Cast Tripods, which I have classified as Subgroup I, and Application Tripods. These two subgroups may well form a continuous development. Both are also characterized by their favouring of applied spiral ornamentation and the handle figures of both comprise single animals (a horse and a bird). However, I also see connections between the tripods of Solid

Cast Tripods, Subgroup II and Matrice Tripods, although they are less striking, e.g. handle types of the former also have relief lines separated by plain parts and the handle figures of both groups consist chiefly of horses and horse leaders, whereas the handle figures of birds seem to be absent in both groups as well as the applied spiral ornamentation. Since both main subgroups of Solid Cast Tripods as well as of Relief Tripods show signs of contemporaneity, I find it reasonable to suggest that the two main subgroups of each category were contemporary, the Application Tripods probably having developed out of the Solid Cast Tripods of Subgroup I, the Matrice Tripods out of Subgroup II.⁸⁹

As stated above, the Geometric bronze tripods found at the Argive Heraion appear to form a continuous development from the Solid Cast Tripods of Subgroup I to the Matrice Tripods, the Application

Fig. 13. (A - B). Athens. National Museum. NM 20817. Relief Tripod. Fragment of open work handle. AH 2784. Drawing and section.

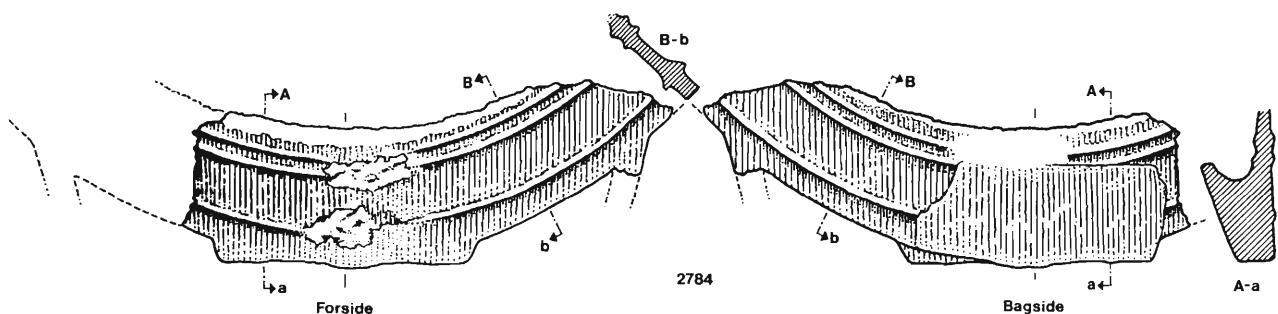



Fig. 14. (A - B). Athens. National Museum. NM 20629 α. Fanned Grooved Tripod. Fragment of leg. AH 2219. Museum photos.

Tripods being conspicuous by their absence.

Tripods with Fanned Grooves.

Tripods with Fanned Grooves have legs of the same construction and form as Relief Tripods, but differ in decoration as well as in handle types. The vertical grooves of the legs show an upper fan-like termination and the handles are either open work handles with flat triangles or solid step handles, to which figures of horses and horse leaders or, in one case, a rider, are either soldered or nailed.⁹⁰

Only one fragment from the Argive Heraion belongs here, AH 2219 (20629 α) (Fig. 14). It is the upper part of a leg with the edge preserved. Along the edge are three nail holes for the fastening of the leg to the cauldron and one nail hole at each side projection. At the back, the projections join the cauldron support which consists of a doubly curving plate, ending

in a cylindrical support. The fragment measures 7.7 cm. in length, 4.8 cm. in maximum width and 3 cm. in width at the lower break.⁹¹ Judging from its dimensions, it must be regarded as a miniature tripod, as Maass observed.⁹²

Hammered Tripods

The hammered tripods are made almost entirely of hammered bronze plate, both handles and legs showing the same stamped ornamentation of running dogs, concentric circles, false spirals, etc. Only the supports for the cauldron and handles - the latter often in the form of standing male figures - as well as the handle figures of horses and horse leaders, which were nailed to the upper rim of the handles, are solid cast.⁹³

At the Argive Heraion were found three fragments of hammered tripods. The largest came from Blegen's excavations below the NE angle of the Upper Hill, the so-called Acropolis. It is a side piece of a



Fig. 15. (A - B). Athens. National Museum. NM 20676 α . Hammered Tripod. Fragment of leg. AH 1748. Fig. 15 A from AH II, pl. CII. Fig. 15 B Museum photo.

hammered leg, ordinary in form as well as in decoration (NM 16555).⁹⁴

AH 1748 (NM 20676 α) (Fig. 15) is a small, very worn and incrustated fragment of a rectangular flat bronze plate, of which both long sides are preserved. It is almost broken in two and has several holes. At one of its long sides, a single tenon is still preserved, identifying the fragment as a side piece of a hammered tripod. Although its decoration is almost worn away, there are remains of engraved lines along its sides and, in between, of diagonal strokes, slightly curving at the ends; there are also traces of at least one circle. The stamped decoration obviously consisted of false spirals framed by vertical lines. The fragment measures 7.9 cm. in length, 0.8 cm. in width and is 0.4 cm. thick. Judging from its width, it must come from a hammered tripod leg of miniature size.⁹⁵

AH 1749 (NM 20676 β) (Fig. 16) is a small fragment of a rectangular bar of solid cast bronze, broken at both ends. The fragment measures 4 cm. in length, 0.8 cm. in width and 0.4 cm. in depth. The bar is slightly curved at one end and shows an irregularly stamped decoration of false spirals between two engraved vertical lines with two outer rows of semicircles. In dimensions as well as in form and decoration, the bar so closely resembles the cast handle supports for hammered tripods from Olympia that I interpret it as a small fragment of such a support.⁹⁶

As AH 1749 was found in the West Building, there seems to be no particular reason for connecting it with the above fragment of a hammered tripod of normal size, which most likely was placed on

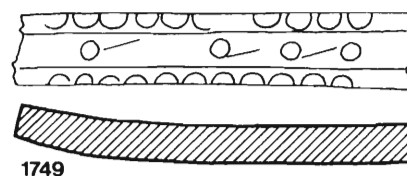

Fig. 16. Athens. National Museum. NM 20676 β . National Museum. Hammered Tripod. Fragment of support. AH 1749. Drawing and section.

the Old Temple Terrace.⁹⁷ The three fragments may well represent three separate hammered tripods at the Argive Heraion.

Chronology

The dating criteria for the Greek Geometric bronze tripods are few. Judging from the style of the figured handle supports of Attic hammered tripods, the greater part of this group should be dated to the late 8th and early 7th Cent. BC.⁹⁸ This seems a reasonable chronology also for the fragments of hammered tripods from the Argive Heraion, one of which presumably had its original place on the Old Temple Terrace built around 700 BC.⁹⁹

As regards cast tripods, only E. Kunze's dating to the last quarter of the 8th Cent. BC of the well-known leg of a Tripod with Fanned Grooves, depicting the fight over the Delphic tripod and with an Orientalizing motif of antithetic lions over a plant ornament, is accepted by most scholars.¹⁰⁰ This date must apply to the comparatively small group as a whole.

The chronology of the two earlier

groups of bronze tripods is less certain. Judging from the preliminary reports of the excavations at Kalapodi, this site may eventually contribute a new and stratigraphically determined absolute chronology. The one published representative of a Solid Cast Tripod of my Subgroup I, a handle fragment, is securely dated to the 9th Cent. BC.¹⁰¹

Most scholars agree to an absolute chronology for Relief Tripods in the third quarter of the 8th Cent. BC. Coldstream dates the whole group accordingly, but several German scholars place the initial phase in the first half of the century, an early chronology for which there does not appear to be any proof.¹⁰² An even later date may be contemplated. There is a close connection between Relief Tripods and Tripods with Fanned Grooves, as regards technical as well as decorative features.¹⁰³ Furthermore, Maass observed that the same moulds were used for the zigzag ornamentation of tripods of the Matrice Group and the zigzag ornamented base plates of the LG horse figures from the Argive Heraion, the production of which should most likely be placed towards the end of the 8th Cent. and the early 7th Cent. BC.¹⁰⁴ These observations indicate that the Matrice Group at least, the only subgroup represented at the Argive Heraion, lasted until the very end of the 8th Cent. BC. If I am correct in my suggestion of contemporaneity between Matrice Tripods and Application Tripods, the latter subgroup should have a similar chronology, i.e. I suggest a production period for the Relief Tripods throughout the second half of the 8th Cent. BC.

Although the initial phase of Geometric Solid Cast Tripods must be placed in the 9th Cent. BC, this date may not apply to the tripods of Subgroup II which apparently started later. As the Argive Heraion fragments of Solid Cast Tripods all seem to belong to a comparatively late phase of production, one even to its very end,¹⁰⁵ I find a date in the first half of the 8th Cent. BC reasonable for the fragments of Solid Cast Tripods from the Argive Heraion.

In sum, the Geometric bronze tripods at the Argive Heraion, representing all four main groups from Olympia, were presumably set up at the sanctuary throughout a period covering the greater part of the 8th Cent. BC and lasting into the early 7th Cent. BC.

Function

The two known find spots of fragments of Geometric bronze tripods which may inform us about their original position probably illustrate the situation at the sanctuary quite well. The early tripods were likely to have been placed in the Altar area only, while one monumental hammered tripod seems to have been placed on the Old Temple Terrace soon after its construction around 700 BC and thus in close connection with the Temple.¹⁰⁶

The function attributed to the tripods, which were originally kitchen utensils, in Greek Geometric sanctuaries is usually that of votive offerings, in particular, of prizes for victors at athletic contests. Undoubtedly, this is the correct interpretation for most bronze tripods, especially those found at the Panhellenic sanctuaries of Delphi and Olympia. However, in the Isthmia publication it is suggested that the iron tripod in the Pronaos of the Temple preceded the nearby perirrhanterion not only in date, but also in function. It might be worth contemplating a similar cultic function for other Geometric tripods, i.e. holding water for the ritual purification which was connected with the entrances to the sanctuaries and to the temple as well as with the altar.¹⁰⁷ It would agree well not only with the above-mentioned find spots in the Argive Heraion, but also with those at Corinth, where the bronze tripod fragments were found in close proximity to the Apollo Temple. However, our information to date is too restricted to allow a general interpretation.

Neighbouring Votive Deposits and Argos

There is no trace of a Geometric bronze tripod in any of the votive deposits near the Argive Heraion, nor, for that matter, in any other sanctuary in the Argolid. None are known from the town of Argos, from which site I know of only one Geometric tripod, in terracotta.¹⁰⁸

Production Centres

Apart from Crete,¹⁰⁹ hardly any of the production centres of the Geometric cast tripods are securely localized. The Tripods with Fanned Grooves are often attributed to Corinth.¹¹⁰ However, in my opinion, their handle figures of horses do not show the normal Corinthian stylistic characteristics¹¹¹. Nor are there any known examples from the Corinthia. They are found at the two Panhellenic sanctuaries of Delphi and Olympia and two local sanctuaries, the Argive Heraion and the Polis Cave on Ithaca, each of which has only one example.¹¹² The tripods stand apart at both of the last two sites, where several examples of Geometric bronze tripods form a continuous development. The metal analysis of AH 2219 shows a considerably higher tin percentage than that of any other tripod analyzed from the Argive Heraion, in accordance with the analyzes of these tripods from both Delphi and Olympia.¹¹³ AH 2219 is of miniature size and thus easily transported. It is most likely a dedication at the Argive Heraion that was manufactured elsewhere. On the existing, slight evidence and restricted distribution pattern, one can hardly expect to solve the problem of localizing the workshops of Tripods with Fanned Grooves and I prefer to leave the question open.

There seems to be a general agreement about a Northeast Peloponnesian manufacture of the Relief Tripods, either Argive or Corinthian, the former having the most supporters.¹¹⁴ As regards Solid Cast Tripods, several production centres are usually advocated,¹¹⁵ although some scholars regard the greater part as Argive.¹¹⁶

Above I have argued for a division into two main subgroups, not only of the Relief Tripods, as stated by Maass, but also of the Solid Cast Tripods, observing a continuation from Subgroup I of Solid Cast Tripods to Application Tripods and from Subgroup II of the former class to Matrice Tripods.¹¹⁷

For a discussion of possible production centres,¹¹⁸ I should like to look at the distribution pattern of the provenances of these four groups:

All four subgroups are represented at the Panhellenic sanctuaries of Delphi and Olympia. The finds from Delos are unusual, but apparently comprise examples of all subgroups in question except the Matrice Tripods. Subgroup I of Solid Cast Tripods are known also from Aigeira in Achaia, Ithaca, Kalapodi in Phocis, Philia in Thessaly and Thermon in Aitolia.¹¹⁹

Application Tripods were found at Dodone, at Ithome in Messenia, on Ithaca and in Laconia, in which last-mentioned region there are also terracotta imitations which may have had Application Tripods as models. A small fragment from Mon Repos on Corfu may belong here, but its subgroup is difficult to decide with certainty.¹²⁰

There are no discrepancies between the provenances of the two subgroups and in neither case do they favour a Northeast Peloponnesian origin. The Solid Cast Tripods of Subgroup I may well have been manufactured over the greater part of Greece, whereas for the Application Tripods a connection with Northwestern Greece, the Western or Central Peloponnese appears more likely, i.e. in the western part of Mainland Greece. At any rate, as far as regards these two subgroups of Solid Cast Tripods and Relief Tripods a Northeast Peloponnesian production centre seems to be out of the question.

Apart from the Panhellenic sanctuaries of Delphi, Olympia and Delos, Subgroup II of Solid Cast Tripods are known today only from the Argive Heraion and Kalapodi.¹²¹ Matrice Tripods were found in the same Panhellenic sanctuaries, with the exception of Delos, as well as at the Ar-

give Heraion, Corinth, Isthmia and Kalapodi. The classification of the above-mentioned small fragment from Mon Repos outside the Corinthian colony of Corcyra is uncertain.¹²² Moreover, we have a close imitation in terracotta from the Heraion of Perachora.¹²³

These two subgroups, Subgroup II of Solid Cast Tripods and Matrice Tripods, are, in particular, connected with the eastern part of Mainland Greece, the Northeast Peloponnese and the eastern part of Phocis, and only for these two subgroups does a Northeast Peloponnesian production centre seem worth considering. As the material presents itself today, an Argive workshop would perhaps appear more likely than a Corinthian one, considering the long line of development of the tripods in question at the Argive Heraion, compared with the few and comparatively late finds in the Corinthia.¹²⁴ Furthermore, at the Argive Heraion we have the zigzag-ornamented bases of the bronze statuettes which used parts of the same matrices as the Matrice Tripods,¹²⁵ and a detail in the figure decoration of one of the metope panels finds its parallels only in Argive pottery, as observed by Coldstream.¹²⁶

On the other hand, at Kalapodi, we find exactly the same line of development respecting the relevant subgroups, Subgroup II of Solid Cast Tripods and Matrice Tripods, and this site likewise gives evidence of local bronze work and even of production of Geometric bronze tripods, although of hammered type.¹²⁷

The evidence for manufacture of Geometric cast bronze tripods at Olympia, proving that cast tripods of monumental size were manufactured at or close to the site where they were erected, and the use of the same matrices for tripods at Isthmia and Olympia, at Kalapodi and Olympia as well as at the Argive Heraion and Delphi, should be taken as signs of itinerant artisans.¹²⁸ Nevertheless, the above distribution pattern indicates specific geographical relations and one should perhaps imagine that as well as frequenting the Panhellenic sanctuaries at their festivals, teams of such artisans had temporary connections with

the more important sanctuaries situated in the larger geographical areas to which they belonged, either the western or the eastern part of the Greek Mainland.

As regards the monumental cast bronze tripods found at the Argive Heraion, there seems no reason to doubt their local manufacture; but in my opinion, they were made by teams of artisans who also worked at other sanctuaries in the eastern part of Mainland Greece, especially in the Corinthia and Phocis, without being permanently connected with any. It is likely that such teams comprised bronze workers of the Argolid and possibly workers trained in the workshops at the Argive Heraion. One should expect a degree of collaboration during the working season between the bronze workers permanently attached to the sanctuary and the itinerant artisans; i. e. in a work-shop which would promote reciprocal stylistic influences.

An important centre for Hammered Tripods was located at Athens.¹²⁹ However, there are signs of more than one Greek workshop¹³⁰ and Hammered Tripods were found in many sanctuaries.¹³¹ At the Argive Heraion, there are a few published examples of Late Geometric/Early Archaic Attic vases, but no evidence for Attic Geometric bronze votives.¹³² Taking into account the continuous development of monumental bronze tripods of presumably local manufacture at the Argive Heraion for about a century, I see no reason why Hammered Tripods at the Argive Heraion should not likewise be considered locally made, although the few preserved fragments do not permit definite conclusions.

As Geometric bronze tripods are conspicuous by their absence in the nearby settlement of Argos and till now not recorded from any other sanctuary in the Argolid, the Argive Heraion may have been the only Geometric sanctuary in the Argolid where monumental bronze tripods were manufactured and set up.

E. Statuettes

When in 1964 H.- V. Herrmann first defined the main regional styles of Greek



Fig. 17 (A - B). Athens. National Museum. NM 13947. Bronze statuette. Horse. AH 12. Museum photos.

Geometric bronze figures, he based his definition of the Argive Geometric style primarily on the bronze figures from the Argive Heraion¹³³ In broad outline his results are still valid. However, the greatest contributions since his pioneer work, the detailed studies of Arcadian bronzes, not distinguished by him as a regional style, have altered our conception of other schools as well.¹³⁴ Thus it seems appropriate to re-evaluate the Argive Geometric style on the basis of our present knowledge.

The Argive Heraion

Apart from the horse leader of a Solid Cast Tripod (NM 16551) (Fig. 3), there are no human figures among the Geometric bronzes at the Argive Heraion.¹³⁵ Most of the quadruped figures are votive statuettes, whereas the birds often form part of pendants or other objects and will be studied separately.

Quadrupeds

The quadrupeds, which are known to number about 15, were found all over the sanctuary.¹³⁶ They consist chiefly of horses and a few deer; bulls and cows are absent, other animals rare.

K. Kilian has stressed the importance of

trying to distinguish bronzes of local manufacture and origin in Greek Geometric sanctuaries from those of local manufacture under foreign influences, from imports, etc.¹³⁷ One of the horses said to have been found at the Argive Heraion is Central Greek and, according to Herrmann's criteria, there are examples of Corinthian as well as Laconian animals.¹³⁸ Although there are still unsolved problems regarding the Arcadian bronzes, it is obvious that this region had a well established production of Geometric bronze figures and at more than one site.¹³⁹ Some of the Arcadian bronzes show such close stylistic affinities to the Argive Heraion animal figures that a strict division between them, which has often proved difficult,¹⁴⁰ will require separate studies of each of the remaining Argive Heraion statuettes.

As the few Argive Heraion animal statuettes of presumably local manufacture are of heterogeneous appearance and, in general, of mediocre quality, Herrmann expanded his study material for the Argive Geometric style to horse statuettes from Olympia as well as to handle figures from cast tripods. Since Herrmann's publication, the two last-mentioned groups have dominated as starting points for attributions to the Argive Geometric style.¹⁴¹ As a Panhellenic sanctuary, Olympia was a meeting place for bronze works and



Fig. 18 (A - B). Athens. National Museum. NM 13943. Bronze statuette. Horse. AH 13. Museum photos.

bronze workers from different parts of Greece. Only two subgroups of cast bronze tripods at Olympia have a distribution pattern which makes an Argive production centre appear at all possible.¹⁴² In my opinion, we are treading on very thin ground in most current attributions to the Argive Geometric style,¹⁴³ and I advise a return to Herrmann's original study material. Only in the local collections can we hope to find criteria for the local style, as Herrmann was the first to realize.

According to Rolley, the Argive Heraion animal statuettes are too varied to be used in a definition of an Argive Geometric style.¹⁴⁴ I should be inclined to agree, were it not for one constant trait which may form a starting point. In contrast with the very varied base plates of Arcadian bronze figures,¹⁴⁵ the base plates of the Argive Heraion Geometric bronze statuettes are almost all of one type and with the same few forms of decoration. All base plates are solid and, with one peculiar exception,¹⁴⁶ rectangular; they have no projection and the decoration of their undersides is primarily in matrice technique, either figured reliefs or zigzag or-

namentation. (Figs. 17 B, 18 B and 21 B).¹⁴⁷

The two horses, AH 12 (NM 13947) and AH 13 (NM 13943) (Figs. 17 -19), have figured reliefs on the undersides of their base plates, in the former statuette framed by a single relief line, in the latter by a double, and in both divided into two metopes by a cross line. In each metope a standing quadruped faces the centre. AH 13 has the most easily discernible decoration. In the left-hand metope, a horse stands tied to a trough with an upper ring, and above it is an indistinct animal, possibly a crouching quadruped with upward curving tail. The quadruped with a highly curving, bushy tail in the right-hand metope seems to be correctly interpreted as a lion; it has a long, narrow snout with open jaws, triangular, forward pointing ears, a round knob-like eye and feline paws. On the hindquarters of the rather damaged horse in the right-hand metope of AH 12 is placed an elongated wading bird, facing right; its neck and the upper part of its body form an almost horizontal line (there is no serpent as suggested in the AH publication). The wild animal in



Fig. 19. Athens. National Museum. NM 13943. Bronze statuette. Horse. AH 13. Drawing.



Fig. 20. Athens. National Museum. AH 13945. Bronze statuette. Horse. AH 11. Museum photo.



Fig. 21 (A -B). Athens. National Museum. NM 13964. Bronze statuette. Lion ? AH 16. Museum photo.

the left-hand metope of AH 12 has an upward curving tail; its head is damaged, but the strokes along the neck may be intended for the bristles of a wild boar. The details of the relief are difficult to understand, as the mould was apparently damaged. The figures of both reliefs are rather blurred and, apart from the horses, the above interpretation cannot be said to be conclusive.¹⁴⁸

Both relief horses have a slender body and thin legs; the horse of AH 13 is in a resting position, while that of AH 12 is walking. The upper line of their bodies is straight, almost horizontal, the lower one curving. Their rumps are high, fore- and

hindquarters broad. The hind legs have an accentuated outline and their tails a straight vertical fall. Both have slender, curving necks, but their heads differ: one is horizontal, the other bent and the only detail rendering appears to be the mane locks of the horse of AH 13.

A similar relief decoration is found on two base plates in Tegea, one of which is even made with the same matrice as AH 13. They must all have the same origin. However, at Tegea, in contrast with the Argive Heraion, they are just two examples of a wide variety of types.¹⁴⁹ Furthermore, the relief horses of the base plates of AH 12 and 13 seem to correspond stylisti-

cally with horses on Argive LG II vases as well as with intaglio horses on some stone seals of a series which, with a few exceptions, come from the Argive Heraion.¹⁵⁰ AH 12 and 13 were most likely local products at the Argive Heraion and the two Tegea statuettes brought from this sanctuary.

The base plates of AH 11 (NM 13945), AH 14 (NM 13965 + 13994) and AH 16 (13964) (Fig. 21 B) have zigzag ornamentation which, according to Maass, formed part of the matrices used for *Matrice Tripods*; this observation can, however, hardly apply to the detached base plate of AH 14 which shows a complete design, not part of a larger decoration. Apparently two more, detached base plates had zigzag ornamentation; they were recorded as coming from the fill west of the Classical Temple, but cannot be identified today.¹⁵¹ Very few base plates recorded elsewhere have similar decoration and apparently none are identical.¹⁵² Except perhaps for the base plate of AH 14, I see no reason to doubt local manufacture of the Argive Heraion examples.

The animal statuettes AH 11 - 14 and 16 (Figs. 17 - 21)¹⁵³ are all solid cast; in most cases the upper part of their legs are flat, although they do not exhibit the extreme flatness of Corinthian animal figures. In contrast to the accentuated outline and cylindrical bodies of Corinthian and Laconian animals, the Argive Heraion figures have a gently curving outline without any angularity or accentuation of details; their broad fore- and hindquarters gradually slant into the curving upper and lower lines of the body. They have a high rump and there is no indication of sex. Their forelegs are slightly bent, sometimes in a "pulling back" position and, except for AH 12, the protrusions of the legs are not articulated. The horses have round hoofs and their tails are long and round and rest on the base plate. Herrmann especially stressed their general impression of vivid movement.¹⁵⁴

Two of the figures do not represent horses but deer with short tails. AH 14 (NM 13965 + 13994); is presumably a

doe. Its clumsy body, flat muzzle and almost complete lack of details are features which are repeated in AH 20 (NM 13968). This is a stag, with one of its horns broken. The two deer are related stylistically; but I do not believe that the latter can be local; it is a much finer work than any other AH animal statuette and its smooth surface has an unusual, light yellowish patina. The underside of its base plate shows an incuse decoration which is not paralleled in those of the local AH animal statuettes.¹⁵⁵ With their flat muzzles, both animals are reminiscent of some Tegean deer, although they have no exact counterparts at Tegea either.¹⁵⁶ In my opinion, AH 14 has the essential characteristics of the above Argive Heraion animals and I am inclined to regard it as a local work, imitating a Tegean deer. AH 20 may be Arcadian.

The second exception is AH 16 (NM 13964)(Fig. 21). Although conforming well to the horses in its bodily characteristics, it has several peculiar features. E.g., its position is almost crouching and its long tail, broken at the tip, does not rest on the base plate, but trails backward, even curving slightly upward at the break. Its neck is thrust forward and is almost cylindrical. The head has a long, narrow, open mouth with indentation forming two rows of triangular teeth; the eyes which are placed so closely together as to be separated by a mere foil of bronze are two circular holes; it has forward pointing, triangular ears and the nostrils are indicated. The animal looks more like a fierce dog than a horse and shares some of the features of the relief lion on the base plate of AH 13 (Fig. 18 B), e.g., as to form and position of ears, position of eyes, form of snout and neck and the free waving of the tail. I suggest that it is also an attempt to render a lion and not much more successful.¹⁵⁷

The remaining bronze figures on local base plates are horses, AH 11 - 13 (Figs. 17 - 20).¹⁵⁸ All three horses are rendered with broad necks, slightly bent heads and manes raised above their foreheads. The heads are more diversified in detail than their bodies. Both AH 11 and AH 12

have cylindrical muzzles and a slight indication in relief of their ears; the latter horse shows hardly any details, whereas the former has a groove round the end of its muzzle and engraved details on the forehead. On the other hand, AH 13 is rich in details; its mane locks are engraved; its vertical ears are rendered in relief, the tips now broken; its mouth is open and its right eye is formed of two stamped concentric circles, an ornament which is repeated on both sides of the neck. On its neck and forequarters is an engraved and stamped decoration, indicating the harness of a chariot horse; presumably all three horses were meant as chariot horses, not riding horses (Fig. 19).¹⁵⁹

As observed by other scholars, the Argive Heraion bronze statuettes are very varied and the same observation may be applied even to horses of the same statuette, e.g. those rendered in relief on the underside of the base plate and those standing on the same plate. Although the closest stylistic counterparts of the former are found in LG II Argive vase-painting, those of the latter are rather Subgeometric than genuinely Geometric in style.¹⁶⁰

Some features were shared by all Argive Heraion animal figures, such as the gentle curves of their bodies with an almost complete lack of vertical or horizontal lines, their slightly bent heads and the restraint in detail rendering or any accentuation of angularity. Most of these traits may also characterize Arcadian bronze figures. Only the sense of vivid movement noted by Herrmann is specific to the Argive Heraion animals. Another peculiarity of the latter group is the distinct, horizontal division of the mouth of several of the animals, a large, horizontal opening which reminds one of the rendering of the mouth of the horse leader of Solid Cast Tripod, NM 16551 (Fig 3). The same trait is observable on the curious little sheep or sheep-like horse on the flat-iron shaped base plate with scratched decoration on its underside, AH 15 (NM 13962), presumably also a local product.¹⁶¹

Two Geometric animal figures remain

to be discussed, both presenting specific problems. The base plate of AH 10 differs from that of the definitely local animals, its underside being decorated with a single wavy relief line. The head of the horse is missing. At first sight, the conception of its body seems to conform well with that of the local horses, but one characteristic feature is lacking: the sense of vivid movement. The posture of this horse is static. Although the figure evidently represents a horse, its tail does not rest on the base as is the case with local Argive Heraion horses. AH 10 is so closely related to one of the Tegea horses (Voyatzis B 13), the base of which has the same decoration, that I am inclined to see a common origin.¹⁶² Although the latter does not actually form part of the most characteristic group of Tegean horses,¹⁶³ I think that an Arcadian origin is more likely for both statuettes than an Argive one.

One small quadruped, AH 22 (NM 13966), is a pendant in the form of a standing ram or sheep. Its base has the same incuse lines as a group of pendants with reclining oxen, most of which come from Tegea, although one example is from Sparta and a ram pendant is from Olympia.¹⁶⁴ However, in contrast with these animals, the Argive Heraion sheep does not turn its head. In this feature it has a parallel in a small stone seal from Philia in Thessaly, which is related to others from the Argive Heraion.¹⁶⁵ The bronze pendant, AH 22, may well be a local product at the Argive Heraion, with affinities to local stone cutting as well as to Tegean bronze pendants.

The Argive Heraion bronze figures were not found in stratified contexts, but are for various reasons usually dated to the 8th Cent. BC.¹⁶⁶ On the whole, we have very few datable contexts with Greek Geometric bronze quadrupeds, and they point, in general, towards the second half of the 8th Cent. BC or the years around 700 BC.¹⁶⁷ The stylistic affinities between the Argive Heraion bronze horses and the horses of the Argive LGII/Subgeometric vases indicate an absolute chronology for the production of Geometric bronze fig-

ures at the Argive Heraion in the late 8th and early 7th Cent. BC.¹⁶⁸ If the lion identifications made above are correct, they provide one more reason for a date late in the 8th Cent. BC, when lion representations became numerous. Apparently, the need for votive dedications of bronze figures was not felt at the Argive Heraion until very late in the Geometric period.

The stylistic characteristics of the Geometric Argive Heraion bronze horses are immediately continued in two horses, the fuller bodies of which mark an Early Archaic date, AH 17 (NM 13984 + 13986) and AH 18 (NM 13944). Only AH 17 preserves a base plate with Geometric zigzag ornamentation in matrice technique, although no longer of the same design as the Matrice Tripods. AH 18 with its more gentle posture and its definitely Archaic body is younger. It seems to be closely connected to a group of horses from Olympia of the first half of the 7th Cent. BC. and both figures should probably be dated to that period.¹⁶⁹

The local Argive Heraion Geometric bronze statuettes (AH 11 -16 and 22) are few and late and display a great variety of animal types. It is worth noting that, in spite of the role known to have been played by cows and oxen in the cult of the sanctuary, these animals are completely absent in the Geometric bronze statuary of the site.¹⁷⁰ The bronze figures are also varied in style. Actually, stylistic consistency is observable only in the reliefs, where the bronze workers were influenced by well-known local media, such as vase-painting and stone seal cutting.¹⁷¹ Considering the unsteady figure style of the statuettes, one would imagine that the bronze workers were also exposed to outside influences.

Contacts with Arcadian bronze work were particularly close. Although the stylistic characteristics separating Argive and Arcadian bronze figures are few and almost intangible, the many studies of the Lusoi-Mantineia bronzes make a distinction possible in most of these cases and the same applies to the typical Tegean animal

figures.¹⁷² There is a difference concerning Laconian traits, so often observable in Arcadian animal statuettes, which are not seen in the local Argive Heraion bronze figures.¹⁷³ It is customary to talk of Argive stylistic traits in Arcadian Geometric figure style.¹⁷⁴ Taking into account, on the one hand, the late date and rather insecure style of the Argive Heraion bronze statuettes and, on the other, the well-established Arcadian Geometric production of bronze figures with independent workshops of high quality at several sites, I am more inclined to reach the opposite conclusion and see the Argive Heraion Geometric bronze figures as primarily modelled on Arcadian bronze statuary, with a particularly close relationship with Tegea.¹⁷⁵

One more characteristic trait separates the two workshops. The life and vivid movement of the Argive Heraion Geometric bronzes are absent in the Arcadian figures and one must look elsewhere for such an inspiration. I find the horse figures of the cast monumental bronze tripods of the groups represented at the Argive Heraion a possible candidate. The Argive Heraion was, as far as we know, the only sanctuary in the Argolid with Geometric cast bronze tripods, all the monumental examples of which belong to Subgroup II of the Solid Cast Tripods or the Matrice Tripods. The horse figures are best known from the latter group and their stylistic features are in no way incompatible with those of the Geometric horse statuettes of the Argive Heraion. They have predominantly softly curving lines, bent heads, often with a distinctly horizontal division of the mouth; their forelegs are slightly bent, they have a high rump and long trailing tail; also they show a similar restraint in detail rendering. The Argive Heraion horse leader (Fig. 3), a handle figure of a Solid Cast Tripod of Subgroup II, also displays some of these characteristics, e.g. the gently curving lines and the prominent, horizontally divided mouth.¹⁷⁶ The essential stylistic differences in the figure style of the two schools of Geometric bronze statuettes in



Fig. 22. Argos. Mus. Inv. B. 75. Athena Sanctuary, Larissa. Bronze statuette. Horse. Photo Ecole Française d'Archéologie, Athenes. Neg. no. 29320.

question, the Argive and the Arcadian, may well be based on differences in their contacts with the bronze workers of monumental tripods. At least Geometric bronze tripods seem to be lacking in the Arcadian sanctuaries.¹⁷⁷ Nevertheless, I do not find the stylistic affinities between the above-mentioned tripod handle figures and the Argive Heraion Geometric bronze statuettes so close that a general attribution of the Matrice Tripods to the Argolid, where they are represented only at the Argive Heraion, would be worth reconsidering. The arguments for itinerant artisans are, in my opinion, too weighty and I should prefer to think in terms of reciprocal stylistic influences.¹⁷⁸

The Argive bronze figures are generally supposed to have a large distribution area. However, apart from the few base plates from the Athena Alea sanctuary at Tegea, no base plates of Argive Heraion statuette types have been published from any other sanctuary, a fact which should be contrasted with the many finds at Olympia for example of Corinthian, Laconian and Arcadian statuette base plates.¹⁷⁹ Keeping to the stylistic criteria of the Argive Heraion statuettes (and thus in accordance with

Herrmann's primary definition of the Argive Geometric style), there seem to be very few possibilities of attributing Geometric bronze figures from other sanctuaries to this workshop. The earlier attributions of Geometric bronze figures from the Athenian Acropolis for example are now recognized as local works, the horses from Sparta are placed on non-Argive base plates and the same applies to the so-called Argive horse from Perachora.¹⁸⁰

Olympia presents a special problem. More than 50 % of all imported Geometric animal bronze figures at this site are classified as Argive.¹⁸¹ Most Argive attributions were based on the handle figures of the central groups of the Solid Cast Tripods and the Relief Tripods, neither of which were definitely localized to the Argolid at the time of publication. The relevant groups comprise the Application Tripods as well as my Subgroup I of Solid Cast Tripods, two subgroups which are not represented in the Argolid at all nor in the Northeast Peloponnese.¹⁸² From stylistic comparisons with these tripods, including the two last-mentioned subgroups, a large Argive regional school has been constructed. It comprises bronze figures from



Fig. 23. Delphi. Inv. no. 3649. Bronze Statuette. Warrior. Photo Ecole Francaise d'Archéologie. Athènes. Neg. nos. 33118 - 33120.

the 9th and the first half of the 8th Cent. BC, when such votive dedications are unknown at the Argive Heraion. Almost 50 % are cows or bulls, animals which are conspicuous by their absence among the bronze figures of the Geometric Argive Heraion.¹⁸³ In general, comparative material from the Argolid is completely lacking for the groups of the so-called Argive bronze figures from Olympia (whether considered original Argive products or manufactured by Argive workers in Olympia). An Argive Geometric figure style constructed on groups of bronzes which have no counterparts in either of the two main sites of the Argolid (Argos and the Argive Heraion) is apt to cause confusion¹⁸⁴ and is hardly a suitable basis for theories about the homeland of the visitors to the sanctuary of Olympia.¹⁸⁵

Our only hope for obtaining a reliable insight into the Argive Geometric figure style and an expansion of the present very limited groups of Argive bronze figures of the 8th/Early 7th Cent. BC is in studies of basically local material.¹⁸⁶

Neighbouring Votive Deposits

There are no Geometric bronze figures from the votive deposits in the neighbourhood of the Argive Heraion.

Argos

I know of only one Geometric bronze statuette found in a sanctuary in Argos, the horse in the Argos Museum, Inv. no B75, from the Athena Sanctuary on the Larissa (Fig. 22),¹⁸⁷ a rather incrustated and damaged statuette. The horse is standing on a solid, rectangular base plate which measures 3 x 1.5 cm and 0.2 cm in height. The underside of the base has a raised rim, inside which are two raised lines forming an irregular, diagonal cross motif; near one end is a transverse raised line and along the long sides two raised triangles; it may possibly be a very schematic figure motif. The horse itself is 3.8 cm. in height. It has a brown patina with greenish spots. Its body is cylindrical and it has a high rump. The legs are round and straight, both fore-

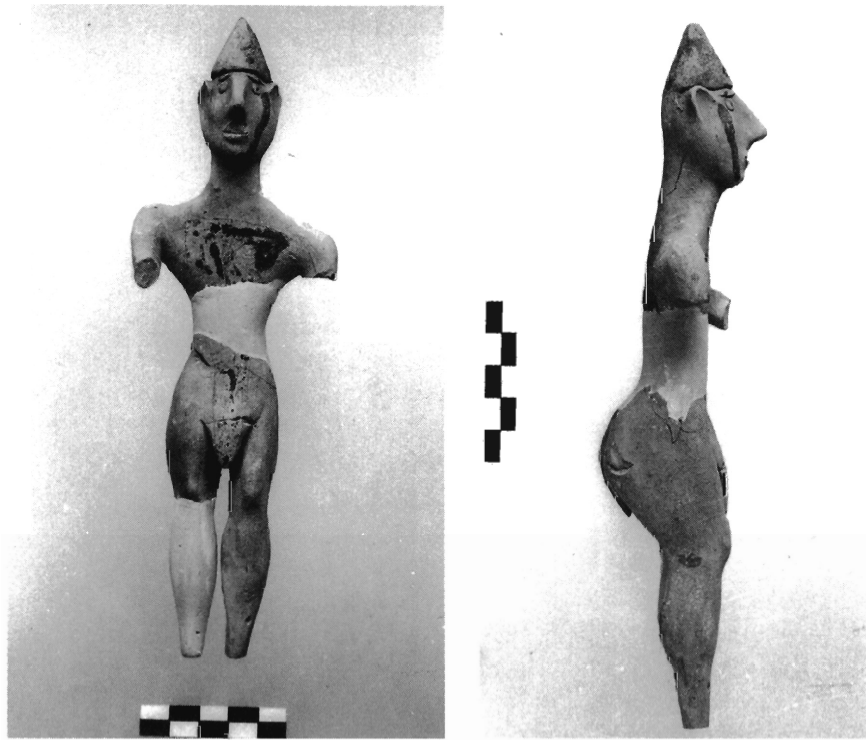

Fig. 24. Terracotta warrior statuette. Argos. Inv. no. C 7830. PhotoEcole Francaise d'Archéologie. Athènes. Neg. nos. 60397 and 60416.

and hindlegs giving the impression of being firmly planted on the ground, the forelegs in a “pulling back” position. The tail is broken off, but originally rested on the base. The head, which is slightly bent, is almost cylindrical, the mane rises high above the forehead; the ears are rendered in relief, turned backward and almost horizontal; the eyes are round and protruding and the mouth is distinctly horizontally divided. Because of the incrustation, the details are rather difficult to observe, but the general impression of the horse is one not incompatible with horses from the Argive Heraion, although it is more compact in build, more firm in posture and more static. It definitely lacks the characteristic feature of vivid movement of the Heraion animals. Nor is it related to the horses of the Matrice Tripods which have much more in common with the Argive Heraion horse statuettes. I have not found any exact parallel, either for the decoration of its base plate, or for the style of the horse and I am inclined to see it as a local product of the site where it was found, the settlement of Argos.¹⁸⁸

This is not the only representative of local Geometric bronze figure production at Argos. H. Sarian has convincingly attributed to Argos a Late Geometric statuette of a warrior from a chariot group, found at Delphi, because of its close stylistic affinities with similar Late Geometric terracotta groups from Argos (Fig. 23). The bronze warrior is naked, the terracotta warriors clad in short tunics; but all wear a large conical helmet and are strikingly similar in the very accentuated outline of their muscular bodies with broad buttocks, as well as in their large heads with large ears, prominent noses and very small mouths (Fig. 24). As the terracotta figures are definitely local, there seems to be no doubt that the bronze warrior is correctly attributed to Argos.¹⁸⁹

The main theme as well as some details connect the terracotta groups to Cyprus.¹⁹⁰ However, the motif of a warrior on a horse-drawn chariot is also known from some Geometric bronzes from Olympia to which the Argos bronze warrior is stylistically related; they are presumably of Laconian origin.¹⁹¹

The Delphic warrior differs considerably from the Argive Heraion horse leader from a cast tripod handle (Fig. 3), where just the opposite physical and facial features are stressed: a slender body and a diminutive face, the only conspicuous feature of which is the large, horizontal mouth. Nor is the theme of a warrior mounted on a horse-drawn chariot known from the bronzes or the published terracottas found at the Argive Heraion.¹⁹²

Apparently we have at least two main centres of manufacture of Argive Late Geometric bronze statuettes, at Argos and at the Argive Heraion, though there presumably were others. It is worth noting that the preserved examples of the two schools differ considerably in motif as well as in style and that we have no evidence of Argos statuettes having been dedicated at the Argive Heraion. The one definitely local Geometric bronze statuette manufactured at Argos shows stylistic affinities with Laconia, whereas the local bronze statuettes of the Argive Heraion do not have any visible ties with Laconia, but appear to be influenced partly by Arcadian bronzes, partly by specific handle figures of cast tripods which are not known from Argos. At both sites, the stylistic characteristics continued into the 7th Cent. BC.¹⁹³

Birds

The Argive Heraion

The Argive Heraion bird figures number about the same as the quadrupeds but were apparently not so widely distributed in the sanctuary. Apart from one bird on the "Upper Hill", they seem to be chiefly connected with the Altar area.¹⁹⁴

The basic studies of Greek Geometric bird figures are those of J. Bouzek, whose regional classifications, however, do not always hold true.¹⁹⁵

Few of the Argive Heraion bronze birds are separate figures, most form part of personal ornaments or other objects.¹⁹⁶

The plate fibula, AH 881 (NM 14033) (Fig. 25) is of island type with triangular bow and has a seated bird on the bow as well as on top of the plate. The latter setting is unusual for genuinely island fibulae and I know of only a few similar examples, one from Lusoi in Arcadia which, however, is a different type of plate fibula.¹⁹⁷

The birds of AH 881 are related to the most common bird type at the Argive Heraion, Bouzek's so-called "Corinthian" bird, a light and elegant small bird with highly swung neck and tail. Its distribution area covers the greater part of Mainland Greece south of Macedonia, with the Corinthia as a conspicuous exception. There is a preponderance of finds in Thessaly and Central Greece. In the former region they are connected with sanc-

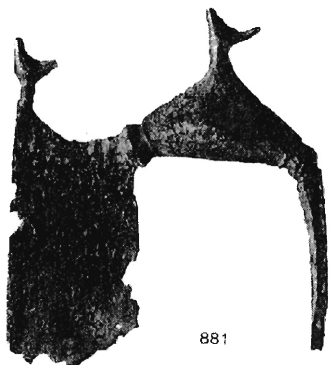

Fig. 25. Athens. National Museum. NM 14003. Plate fibula. AH 881. From AH II, pl. LXXXVII.



Fig. 26. Athens. National Museum. AH 13953. Bird pendant. AH 40. Museum photo.



Fig. 28. Athens. National Museum. NM 16971. Bird pendant. Argive Heraion.
Photo American School of Classical Studies, Athens.

object may be of Central Greek origin.²⁰²

The small, badly preserved bird, AH 38, on a broken cylindrical standard, has stylistic features that are typically Thessalian: protruding round eyes and a prominent breast. Its closest parallels are found in Pherai and Philia.²⁰³ The same general characteristics are shared by AH 42 (NM 13956), a bird on a circular open-work base, horizontally pierced through its neck, presumably likewise of Thessalian origin.²⁰⁴

AH 44 is a hollow cast duck with incised wings and modelled flippers. Judging from the square hole on its underside and the traces of wear around the hole, AH 44 was apparently placed on a separate vertical bar. It has counterparts among Thessalian birds, but because of its lack of suspension ring, it was presumably produced elsewhere and may be a local variety. As the Argive Heraion bird is comparatively naturalistic, it should be dated after 700 BC.²⁰⁵

NM 16971 (Fig. 28) is a bird on a vertical stem; with its plump body and short beak it is related to a bird type with rather long legs, especially known from Laconia.

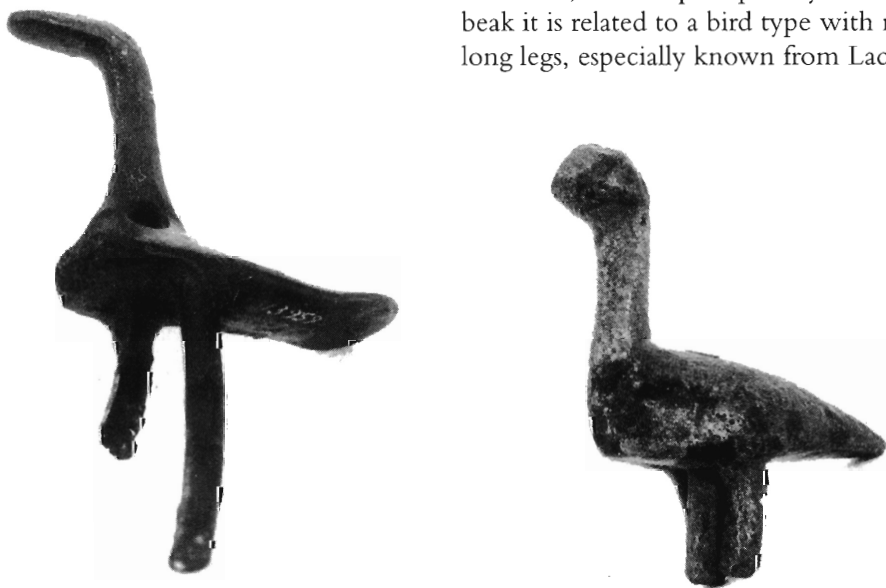

Fig. 29. Athens. National Museum. NM 13958 and 13959. Bird pendants. AH 36 - 37. Museum photos



Fig. 30 (A - B). Athens. National Museum. NM 13952. Bird pendant. AH 47. Museum photos.

However, the closest parallels for the cross decoration on the underside of its circular, solid base plate are found in some stamp pendants from Tegea. Perhaps it is actually an Arcadian figure under Laconian influence, a category into which several Arcadian birds as well as quadrupeds fall.²⁰⁶ In the irregularity of its vertical stem, it also resembles another Central Peloponnesian bird type with a horizontally pierced body and an open work, circular base. Although these birds usually have legs, not a stem, it seems to be within this latter group that the bird, AH 43, (NM 139611) with its long tail finds its closest parallels. The birds of this group have been found at Olympia, in Arcadia and Laconia and recently a production at Lusoï has been suggested for a very similar type. AH 43 seems to be the only bird figure at the Argive Heraion of possibly Laconian origin, but like NM 16971 it should perhaps be regarded as an Arcadian bird with Laconian influence.²⁰⁷

AH 36 - 37 (NM 13958 - 59) (Fig. 29) are likewise long-legged birds. They have long necks, hardly any detailed rendering, and bodies with flat, horizontal undersides. AH 36 has a horizontally pierced neck. One of its legs is broken. As the foot of its one well-preserved leg shows a rough underside, it probably was originally placed on a base plate. AH 37, of which

only the tip of its beak is missing, has a central hollow cylinder between its legs; since the underside of its body shows traces of wear, the bird was apparently meant for insertion into another object, just like AH 44. It is comparatively light and presumably hollow cast.²⁰⁸ The two birds have been compared to Thessalian as well as to Laconian birds, whereas Bouzek recognized them as Argive, in my opinion correctly. One of their two counterparts in the sanctuary of Tegea was placed on a base with a relief decoration on its underside, comparable with the horses on the bases of the Argive Heraion horse statuettes, AH 12 - 13. Most likely all four birds were produced in the same workshop, i.e. at the Argive Heraion.²⁰⁹

The remaining birds, AH 45 - 48, (without Inv. no.; NM 13979, 13952 and 13954) are all cocks, each with identical ornamentation on both sides, a variety of incised and stamped decoration of lines and concentric circles.²¹⁰

The badly preserved and incrustated bird, AH 45, seems to be of the same type as AH 46, a solid cast, small cock with flat crest and tail. AH 46 was vertically pierced and definitely served as a pendant.

The cock AH 47 is hollow cast, larger and with two profiled rings at the neck as well as at the base of the tail. Its eyes are round and raised and it has large triangular

feet. Originally functioning as a pendant with a suspension ring on top of its back, it was turned into a fibula when the ring was broken. At the side of its body is an irregular, oblong hole; soldered to the inside of the undamaged side was a bronze plate with a long vertical pin, preserved to a length of 5.3 cm.; its tip is broken (Fig. 30).

The body of AH 48 is likewise hollow cast. The bird has protruding, round eyes and long flat feet; its crest is broken off as well as the top of the suspension ring on its back.

The small, solid cast cocks, AH 46 (and presumably also AH 45), must be regarded as Thessalian imports, whereas AH 47-48 are Arcadian, probably of Tegean manufacture.²¹¹

The function of the Argive Heraion bird figures varies. There are a few statuettes and a few fibulae but most birds were pendants, presumably worn as breast ornaments. At least one of the cocks, AH 47, was a dedication of a used article of dress and also AH 37 and 44 may have been in use before being offered, but here as in many other cases, the exact function is not easy to determine.²¹² Like the quadrupeds, the bronze birds found at the Argive Heraion are of varied types and not particularly connected with Hera.²¹³

Presumably the chronology of the Argive Heraion bronze bird figures is about the same as that of the quadrupeds, i.e. a LG date, most likely the last quarter of the 8th Cent. BC. and the early 7th. Cent. BC. Judging from the few certain find contexts of chronological importance, the general chronology of Greek Geometric bronze birds seems to be Late Geometric. One of the closest parallels to the Central Greek birds at the Argive Heraion was found in a stratified context at Kalapodi, dating to the last quarter of the 8th Cent. BC.²¹⁴

The Argive Heraion had apparently an even more limited manufacture of Geometric bronze birds than of quadrupeds, the majority having been brought from outside. While there are birds of definitely Thessalian origin, the closest ties were with Central Greece and Arcadia. There existed also a local manufacture of bird figures at the Argive Heraion, a few ex-

amples of which were found at Tegea.

There are no certain Macedonian imports and the apparent influences from Laconia may well be indirect, via Arcadia. Geometric bronze bird dedications seem to represent a secondary tradition in the Northeast Peloponnese; in the sanctuaries of the Corinthia, we have even fewer such dedications and, as far as I know, no evidence for a local manufacture of Geometric birds.²¹⁵

Neighbouring Votive Deposits

There are no finds of Geometric bronze birds in any of the neighbouring votive deposits.

Argos

I know of no Geometric bronze birds from any of the sanctuaries of Argos and of only one from a cemetery. It was found in the earth above a Protogeometric tomb. It is of Central Greek bird type, but its base is four-legged in cross-form, a type which I. Kilian - Dirlmeier has recorded in only five examples. Two are without provenance, one is said to have come from Thessaly and one was found in a LG context at Amphikleia in Phocis.²¹⁶ This specific type is not known at the Argive Heraion; but although it may indicate outside connections different from those of the Argive Heraion, these connections also extended to Central Greece.

There is no reason to suppose the existence of a local production of bronze bird figures at Geometric Argos, nor at any other site in the Argolid apart from the very limited one at the Argive Heraion.²¹⁷

F. Personal Ornaments

In some cases personal ornaments of bronze which formed part of the dress were dedicated in a sanctuary together with the whole dress, although separate offerings also occurred.²¹⁸ As regards personal ornaments of bronze at the Argive Heraion, we have no evidence for any specific manner of dedication and only a



Fig. 31 (A - C). Athens. National Museum. AH 1557 - 1558 and 2753. (NM 13987 and 20909 α). Stamp pendants and pomegranate pendant. Fig. 31 A - B Museum photos. Fig. 31 C from AH II, pl. CXXXIV.

few objects are certain to have been in actual use before dedication.²¹⁹

Comparative studies of this very large group of objects must be based on detailed examinations by other scholars, especially in the German publications of "Prähistorische Bronzefunde".²²⁰

Pendants

The Argive Heraion

Apart from the bird pendants, very few pendants were found in situ at the Argive Heraion, the known find spots almost always being the secondary location of the Southern Slope.²²¹

Some of the pendants are of rather common types as e.g. miniature double axes and wheel ornaments, both of which are known from a single example at the Argive Heraion. The double axe (Fig. 27) measures 6.3 cm. in width and 0.2 cm. in thickness; it has curved sides and to its central part was attached a separate, presumably wooden, handle, the rivet for the fastening of which is preserved. According to I. Kilian-Dirlmeier, this type of double axe was widespread over the greater part of the Greek Mainland. The same observation applies to the wheel ornament which measures 20 cm. in diameter; each of its four circular holes, cut out of 2 mm. thin bronze plate, measures 6.6 cm. in diameter. Both ornaments may well be separate votives. Only miniature double axes with a fixed stem seem to be known as

dress ornaments and although counterparts to the wheel ornament have been seen in tombs as decoration of the neck or breast and one wheel ornament from Kalapodi was found fastened to a fibula, the Argive Heraion ornament is probably too large to have been used as a dress ornament. As isolated objects at the Argive Heraion, both pendants were most likely manufactured outside the Argolid. They may be of LG date, but in both cases the type continues.²²²

The rest of the bronze pendants at the Argive Heraion are imports and connected to two regions, Arcadia and Macedonia. Two stamp pendants, AH 1557 - 1558 (NM 13987) are of Arcadian, presumably Tegean, manufacture; the former is a pyramidal stamp, the quadrangular base of which shows a cross design, the latter has a circular base plate with a wheel design. The same origin must be ascribed to the only pomegranate pendant known from the Argive Heraion, AH 2763 (NM 20809 α) (Fig. 31). According to I. Kilian-Dirlmeier, stamp pendants may have had a double function: as ornaments, possibly amulets, and as signets. Their chronology is chiefly LG, but like the pomegranate pendants they lasted into the Archaic Period.²²³

The Macedonian type pendants at the Argive Heraion are partly Macedonian imports, partly Greek imitations. The former group comprises the lower part of a cast pyxis pendant, AH 2019 (NM 2079), a bell pendant, AH 1556 (NM 20672 γ) and different kinds of beads, AH 1548 -

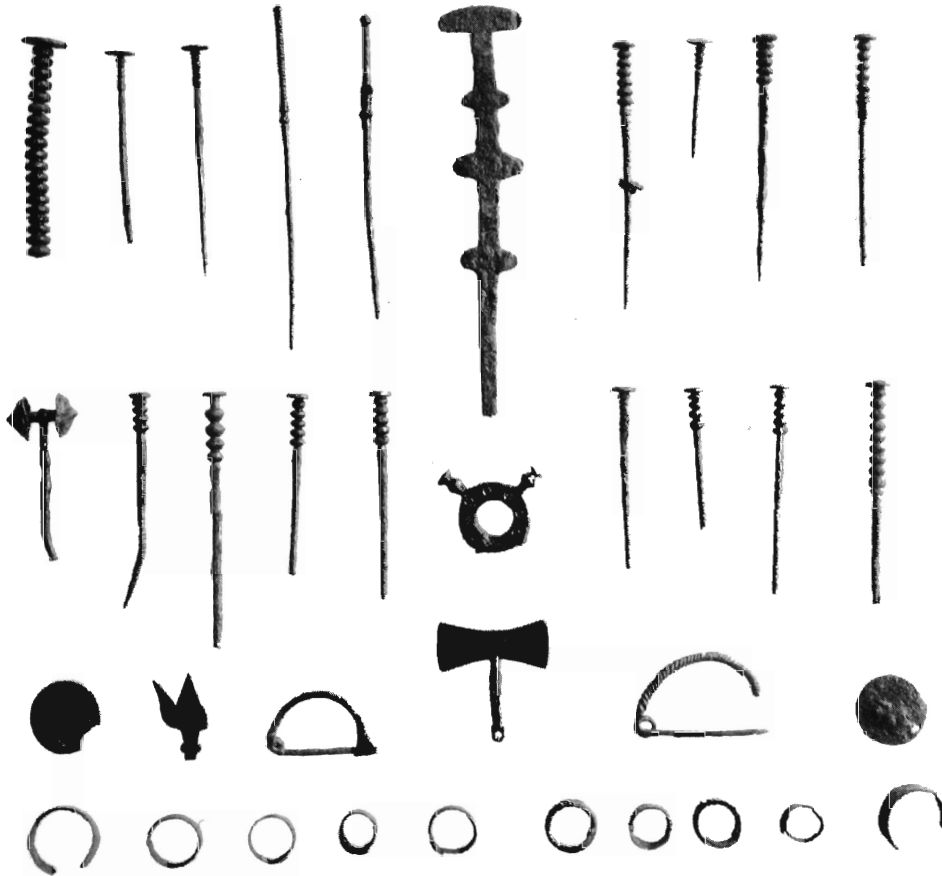

Fig. 32. Argos. Museum. Fibulae, pendants, pins and rings. Athena Sanctuary. Larissa. Photo Ecole Francaise d'Archéologie. Athènes. Neg. no. 53768.

1550 and 1552;²²⁴ among the beads are also Greek imitations, AH 1547 and 1551, with counterparts in many Greek sanctuaries.²²⁵ Whereas the Macedonian imports seem to be dated to the 8th or early 7th Cent. BC, the Greek imitations may be as late as the end of the 7th Cent. BC.²²⁶

Neighbouring Votive Deposits

There are no certain Geometric pendants from any of the neighbouring votive deposits, as a fragmentary wheel in lead from Tomb L at Prosymna presumably does not form part of a pendant.²²⁷

Argos

The one known miniature axe from a sanctuary in Argos, the Athena Sanctuary on top of the Larissa, B 76 (Fig. 32), differs from the Argive Heraion example in

being cast in one piece with its stem possessing a suspension loop. It has tremolo decoration. This type of double axe is connected, in particular, with sanctuaries in Sparta and Arcadia.²²⁸ A flat ring pendant with protuberances, also from the Athena Sanctuary (Fig. 32), is presumably an import from Tegea where an exact counterpart was found. A fragment of a similar pendant decorated with small knobs from the Aphrodision (70/1553) seems closer to a ring pendant from Pherai. A pyramidal stamp pendant from the Aphrodision (69/592) is probably Arcadian.²²⁹ Judging from their location, the two last-mentioned pendants should presumably be dated to the late 7th Cent. BC, at the earliest.²³⁰ As they are of the same types as the Geometric pendants, a later date is possible also for the corresponding ring pendant from the Larissa sanctuary and the stamp pendants from the Argive Heraion.

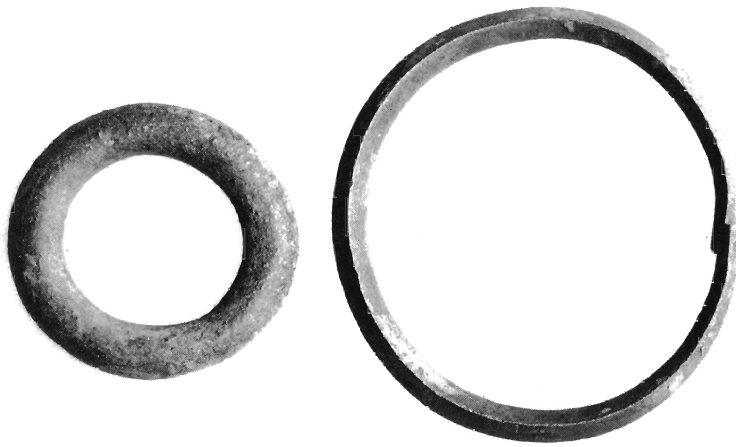

Fig. 33. Athens. National Museum. Armrings. Argive Heraion. Photo American School of Classical Studies, Athens.

As regards non-figurative bronze pendants, the Argive Heraion and the sanctuaries of Argos all had their strongest ties with Arcadia, in particular Tegea. However, pendants from the two sites show differences in types as well as in details; for example, the ring pendant with protuberances is not found at the Argive Heraion and the two miniature double axes had different stems. In the sanctuaries of Argos there are no certain Thessalian or Macedonian Geometric bronze pendants.²³¹ The Argive Heraion shows a wider variety of non-figurative pendants, but both sites give the impression that bronze pendants never played such an important role as to promote a local production and, apart from the Northern Greek connections observable only for the Argive Heraion, imported pendants indicate contacts with the same Greek regions, although not always with the same workshops.

Rings

The Argive Heraion

The different types of rings were found all over the sanctuary. There are only two ear-rings which may be Geometric, AH 1553 (NM NM 20672 α) and AH 1554 (NM 20672 β), the latter of which was found near the Altar.²³² Both are hoop ear-rings. AH 1553 is formed as a spiral end-

ing in knobs. The type has a wide distribution in the Greek Mainland, Eastern Greece and the islands, and may be of Near Eastern origin. The loop of AH 1554 ends in flat disks. There are several counterparts in terracotta from the Argive Heraion, at least some of which have disks with painted cross division. They are known in gold from the Hera Akraia and the so-called Hera Limenia deposits at Perachora as well as from two Geometric tomb contexts said to have come from Corinth. All of these have disks with incised cross decoration. Both this type and a variant with the disks formed into cones have a wider distribution area, but they seem to be especially favoured in the Northeast Peloponnese. The latter variant is represented in terracotta at Tiryns, also with painted cross division. From its counterparts in the Corinthia, AH 1554 should most probably be dated to the 8th - 7th Cent. BC and a corresponding date may be given to AH 1553.²³³

There are a few arm rings at the Argive Heraion which may be Geometric. Mostly they are plain rings. Some have overlapping ends such as AH 1359 or the slightly elliptical AH 971. Other rings were closed, as the rings with angular section, AH 1361 and 1362. The latter has tremolo decoration. Like the Macedonian ring with rhomboid section found by Blegen (Fig. 33), the type indicates relations with Thessaly/Macedonia; but, although they have earlier northern counterparts, they should presumably be dated to the 8th or 7th Cent. BC.²³⁴ There seem to be a few fragments of flat arm rings with rolled ends, AH 816 and possibly AH 815, dated to the 8th - 7th Cent. BC. To the same period belong the Boiotian arm rings; their flat central parts have ornamental tremolo decoration and their rounded ends have raised rings, AH 1597 - 1599 (NM NM 210531α, β and γ)(Fig. 34). They are found in 8th - 7th Cent. contexts, in particular, in and around Thebes, and are known also from Attica, Aegina, Locris and Olympia, as well as in a varied form from Thessaly. The examples outside Boiotia are too few for any theories of a

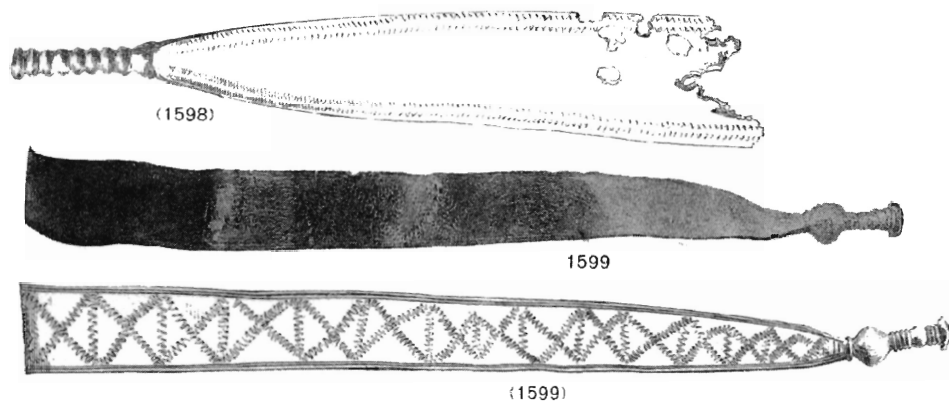

Fig. 34. Arm rings. AH 1597 - 1599. NM210531 β , γ . Drawings. From AH II, pl. XCIX.

possibly secondary production in another Greek region. Two arm rings have profiled rings at their ends, AH 972 (NM 20914) which is a wire decorated plain arm ring, and AH 972 a, possibly a child's arm ring. Both are presumably of Geometric or Early Archaic date and their types are widely distributed in Greece.²³⁵

The Argive Heraion has a large collection of plain finger rings (AH 950 - 960 and 975 - 1356), the date of which is often difficult to determine but presumably several belong to the Geometric Period. Like the other personal ornaments, they must be regarded as dedications to Hera, although we have only one example with such a dedicatory inscription, an Archaic gold ring which possibly came from the Argive Heraion. There are a few wire rings, as e.g. AH 1464, which are also difficult to date. Finger rings with an angular section, as AH 1363 - 1380, are known in the Geometric Period from many Greek regions. One finger ring, AH 1509 (NM 20671), is made of a flat piece of bronze ending in spirals, a type which is common all over Greece from the Submycenaean Period until well into the 7th Cent. BC. Its spiral is rather small and the ring probably belongs to the later production period, the 8th or 7th Cent. BC. There are several band rings made of a plain piece of sheet bronze, sometimes with a central ridge and often with tremolo decoration that secures their Geometric or early 7th

Cent. date (AH 1480 - 1482, AH 1495 and AH 1505 - 06).²³⁶

Neighbouring Votive Deposits

The Hera sanctuary west of the Argive Heraion has one example of the same type of ear ring as AH 1553 as well as two plain arm rings and several plain finger rings (Fig. 35). The latter type was discovered also in some Prosymna Tombs (Tombs II, X and L) and here there are several band finger rings, one of which, from Tomb IX, has an incised decoration along the edge (Fig. 36).²³⁷

Argos

Plain bronze finger rings, sometimes in the form of band rings and often with tremolo decoration, are found both in sanctuaries (Fig. 32) and tombs in Argos and in the former contexts there are also wire finger rings (Fig. 43) as well as finger rings of angular section. The chronology of all these types of finger rings seems to cover the greater part of the Geometric Period lasting into the 7th Cent. BC and they are found all over the Argolid.²³⁸

The ordinary finger rings, presumably locally made at both main sites, do not differ noticeably and are represented also in the votive deposits near the Argive Hera-

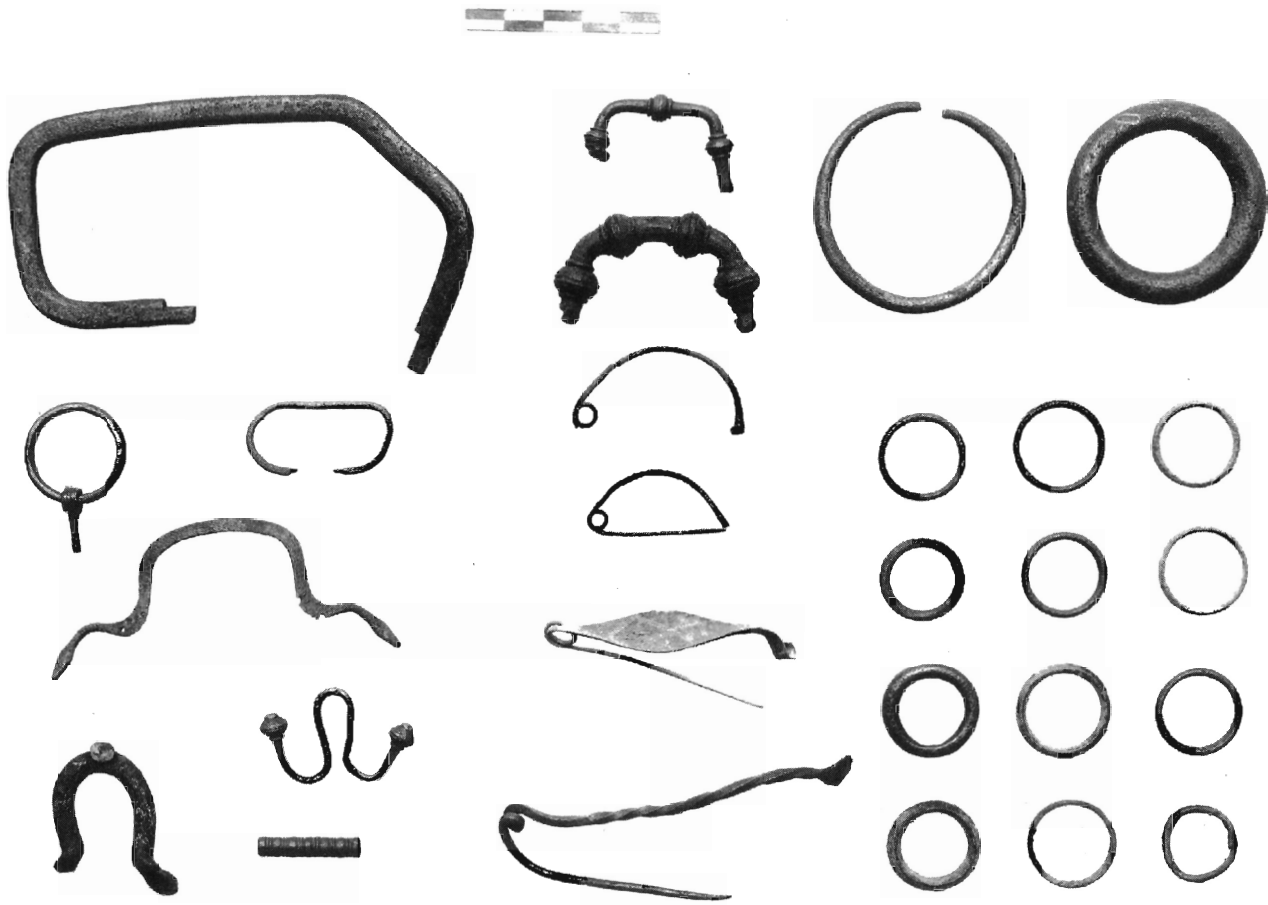

Fig 35. Athens. National Museum. Ear ring, fibulae and finger rings. Hera Sanctuary west of Argive Heraion. Photo American School of Classical Studies, Athens.

ion. The other ring types known from the Argive Heraion seem to be absent in Argos. The hoop earrings with disks indicate participation in a common tradition over a large part of the Northeast Peloponese, including the Corinthia. The Argive Heraion arm rings, not paralleled in Argos, are in several cases of either Central Greek or Northern Greek types.

Fibulae

The pioneer studies of Greek fibulae published in 1926 by the Danish scholar Chr. Blinkenberg have been followed by detailed studies by many scholars; in particular, some of the PBF publications have contributed new information on chronology and regional attributions.²³⁹

The Argive Heraion

The fibulae at the Argive Heraion form a comparatively large group of personal ornaments, in all about 110 examples, including Near Eastern and Italic fibulae as well as close imitations of both categories. They were found all over the sanctuary but with a preponderance of finds in the West Building and on the Southern Slope.²⁴⁰

Of the Greek Geometric fibulae, the arched fibulae, chiefly Blinkenberg's Groups II and III, are well represented at the Argive Heraion.²⁴¹ Although the type originated in the Sub-Mycenaean/Proto-geometric Periods, there is no secure evidence for Blinkenberg's early date for e.g. AH 831, as its type continued into the Archaic Period.²⁴² AH 844 - 845, both

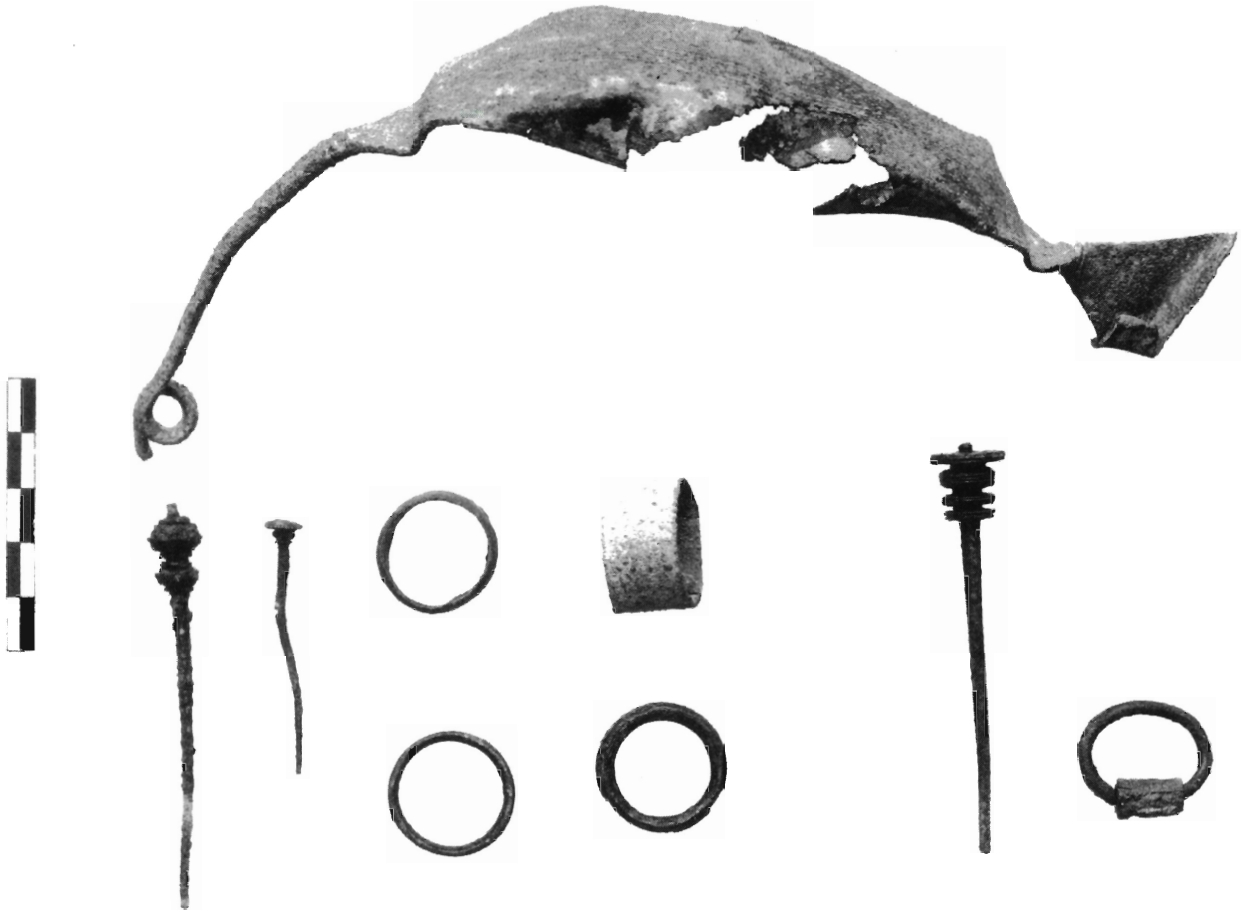

Fig. 36. Athens. National Museum. Bronze fibula, rings and pins. Prosymna Tombs. Photo American School of Classical Studies, Athens.

with a twisted bow which Blinkenberg considered intermediary between Submycenaean and Advanced Geometric, may date to the late 8th or the 7th Cent. BC. The fibulae are of a variety especially known in the Central Peloponnese: Sparta, Lusoï and Tegea, but found also elsewhere in the Peloponnese, e.g. in Perachora, as well as on Ithaca. There are a few well-preserved simple arched fibulae, as e.g. AH 829, AH 839 and the miniature fibula, AH 830²⁴³, but most are too fragmentary for classification and some are definitely remnants of Italic type fibulae, originally decorated with disks of bone or other material.²⁴⁴

The more specific forms of Greek arched fibulae at the Argive Heraion are to a great extent either insular types or of Thessalian origin. AH 838 and 841 have an arch of slightly swollen form, a type which is also found in Exochi on Rhodes

as well as at Perachora, in the so-called Hera Limenia deposit, but is well-known also in Thessaly. Their date is late 8th - 7th Cent. BC. and so is that of the Thessalian fibula AH 833, a large number of which type were found in Pherai, while there are representatives also from Philia, Perachora, Amyklaion and Lindos. AH 843, with a rhombic arch bordered by double incised lines, is of an island type which continues into the Archaic Period.²⁴⁵

Ring fibulae, AH 919 - 934, consisting of a solid ring, a few cm. in diameter, with a pin attached to the back, reach back at least as far as the LG Period/Early 7th Cent. BC, but their exact chronology is not easy to establish.²⁴⁶

Spectacle fibulae from the Argive Heraion, Blinkenberg's type XIV, are known mostly in small fragments with only one fully preserved example, AH 818 (NM

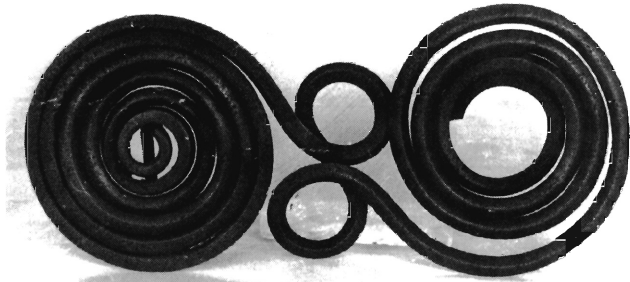

Fig. 37. Athens. National Museum. Spectacle fibula. AH 818. NM 14035. Museum photo.

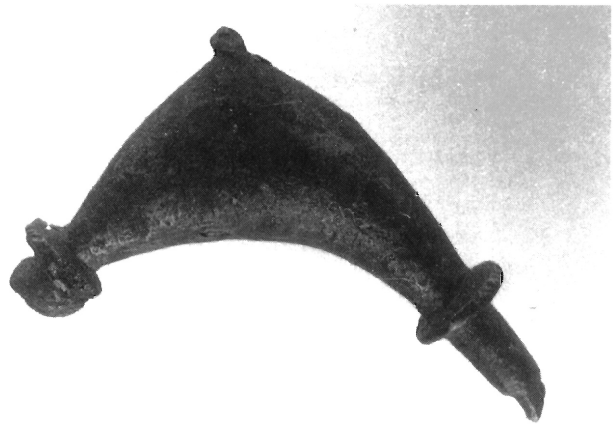

Fig. 38. Athens. National Museum. AH 880. NM 20888. Arched Fibula. Museum photo.

14035)(Fig. 37). It is of the type normally found in the Peloponnese, made of one piece of wire, quadrangular in section, except for pin and hook, and with a double central loop in a so-called “Achter-Schleife”. Spectacle fibulae which originated in Central Europe and the Northern Balkans apparently reached Southern Greece via Macedonia and Thessaly. They are found in Macedonian and other Northern Greek tombs in the 9th Cent. BC and there are Central Greek and Peloponnesian contexts of the late MG and LG periods indicating an 8th - early 7th Cent. date as also likely for the Argive Heraion specimens. Double spectacle fibulae with four spirals are not represented at the Argive Heraion, while there are some examples of related spectacle fibulae of bone or ivory, Blinkenberg’s type XV.²⁴⁷

A violin fibula type with a rectangular plate where two small rivets, as suggested by Blegen, may have fastened a decorative oblong piece of ivory, bone or wood is common at the Argive Heraion. Their distribution area covers many Greek islands as well as the Peloponnese and their chronology extends from LG until some time in the 6th Cent. BC.²⁴⁸

Among the plate fibulae at the Argive Heraion are one arched fibula with a very small catch plate, AH 836, and two island type fibulae, AH 881 and AH 880. AH 881, with birds both on the catch and on the bow (Fig. 25), is possibly an Arcadian variety, whereas AH 880, with a triangu-

lar, swollen arch bordered by two rings, and decorated on the top with a small round projection (Fig. 38) is presumably a Thessalian variant, both dated to the late 8th or early 7th Cent. BC.²⁴⁹

The very fragmentary fibulae, AH 869 - 870 (NM 14032), with a central globe on the arch and probably a small catch plate are definitely island fibulae. They have a large distribution area over almost all Greek islands. Having developed from an older type known in Euboea and Skyros, they continue into the 7th Cent. BC. They are also well-known at Pherai, but apparently not north of Thessaly, and there are examples on the West Coast of Asia Minor, at Artemis Orthia at Sparta and in Central Greece.²⁵⁰

The large plate fibulae, the arches of which are decorated with large pearls and globes, AH 871 - 875 and 877 - 879 (NM 20889, and 14032 - 33) (Fig. 39), Blinkenberg Type VII, are basically of Thessalian type, a large percentage of which come from Pherai. However, as shown by B. Philipp, who bases her conclusions on earlier studies by Payne and Schweitzer, the fibulae found outside Thessaly form two different subgroups. AH 873, one of the Artemis Orthia fibulae, two from Andritsena and the Olympia fibulae, Ol 1009 and 1011, are considered genuinely Thessalian, whereas the bulk of the Argive Heraion fibulae as well as most of the other fibulae from outside Thessaly are considered variants of the Thessalian type. A

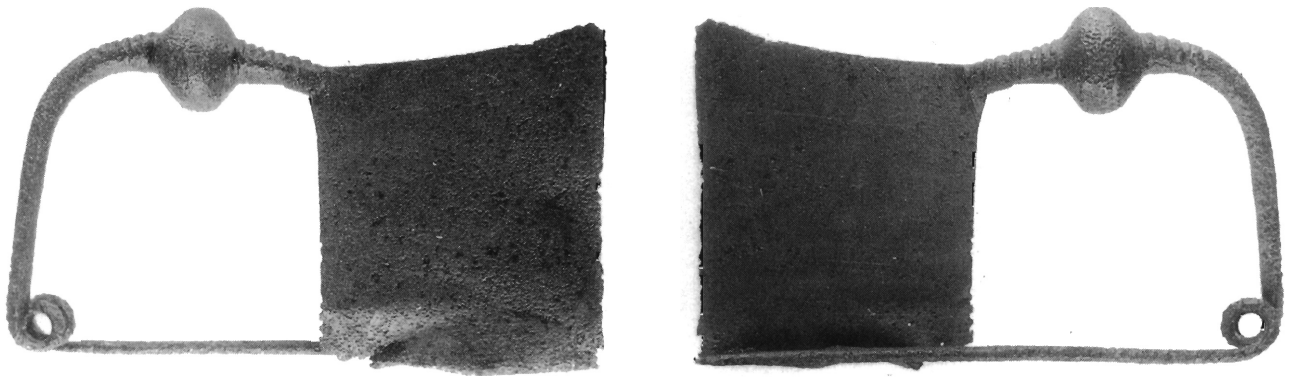

Fig. 39 (A - C). Athens. National Museum. Plate fibula. NM 14033. AH 879. Fig. 39 A - B Museum photos. Fig. 39 C Drawing.

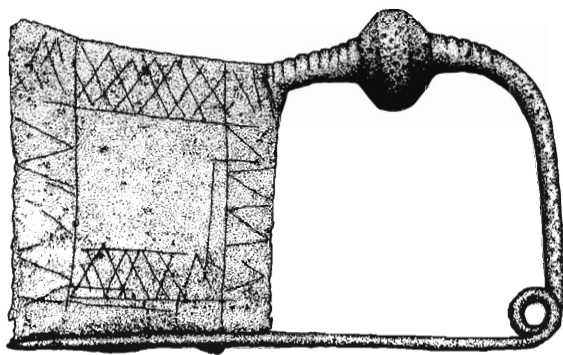

Fig. 39 C.

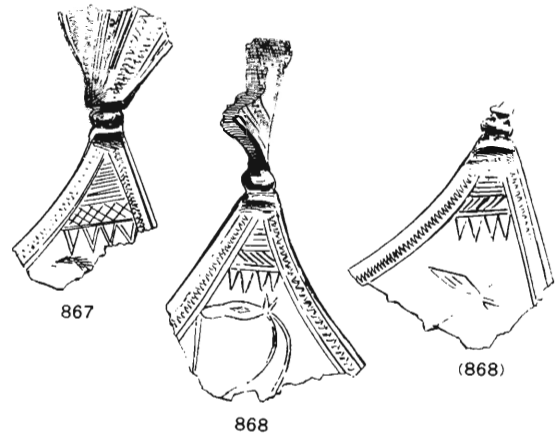

Fig. 40. Athens. National Museum. Fragmentary plate fibulae. AH 867 - 868. Drawings. From AH II, pl. LXXXV.

Central Greek as well as a Peloponnesian workshop are possibilities. B. Philipp does not localize the place of manufacture, whereas other scholars advocate an Arcadian origin for most fibulae found in the Peloponnese. The arch fragments, of which most of the Argive Heraion fibulae consist, cannot contribute to the discussion. Their chronology is late 8th - early 7th Cent. BC.

Only AH 879 (NM 14033) is well preserved, although badly worn (Fig. 39). It measures 8.7 cm. in length and 5.2 cm. in height. Along the border of the inside of the fibula, the decoration is still observable, a rather crudely engraved cross-pattern which leaves a central square open and apparently undecorated. A possible engraved ornamentation of the outside of the fibula cannot be observed. As this specific kind of linear ornamentation is not

found on the other Thessalian or Thessalian type fibulae, it may be an indication that AH 879 was actually manufactured at the sanctuary.²⁵¹

Among the plate fibulae at the Argive Heraion are also examples of Blinkenberg Type VIII, the so-called Attic-Boiotian fibulae which developed in MG Attica and had their main LG production in Boiotia. There is one fragment of a bow with three disks, AH 858, six stems, AH 859 - 860 and 862 - 865, and two uncertain stem fragments, AH 861 and 866, as well as two fragments which comprise the lower part of the stem and the corner of the plate, AH 867 - 868 (Fig. 40). Most fragments have incised decoration, on the stems of Geometric ornaments, on the plates of animal figures, only one of which is definitely a horse (Fig. 40 b). The figures are framed by zigzags between double



Fig. 41. Athens. National Museum. Plate fibula. Argive Heraion. From Hampe 1936, pl. 17.

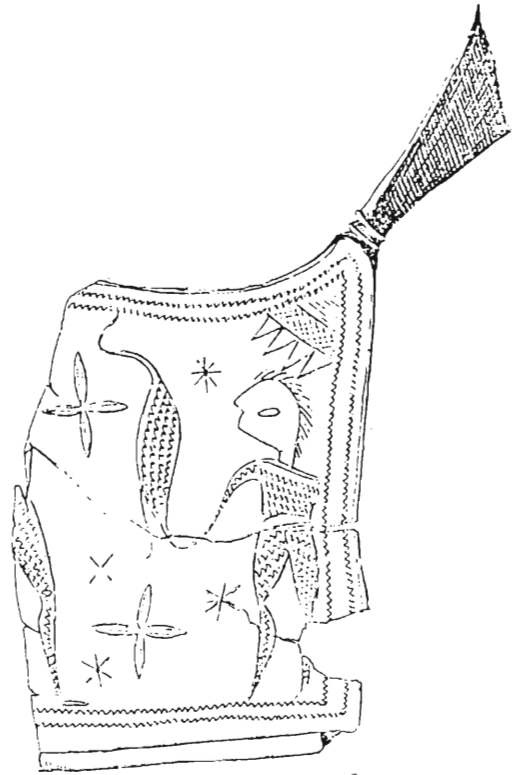

Fig. 42. Athens. National Museum. Plate fibula. Argive Heraion. Drawing. From Blegen 1939, 441, fig. 28 B.

lines and the corner decoration consists of horizontal lines nearest the stem, chequer pattern (AH 867) or diagonal lines (AH 868) and near the figure decoration a series of triangles.²⁵²

One fragmentary Boiotian plate fibula was found in Blegen's excavations. Almost the whole catch-plate of a very large fibula is preserved, measuring 14.5 cm. in length and 8.5 cm. in width. The figure scene is framed on both sides by a double zigzag line and it has the same corner decoration as AH 867. Two apparently unarmed men stand facing each other; they are drawn in outline with the normal zigzag filling of their bodies. In the field are scattered rosettes and stars and in the centre a strange curved object, also in outline, with a filling of zigzags. Hampe identified it as a bird; it differs considerably from the normal bird representations of these fibulae in being thin and distorted. The heads

of the men are disproportionately large and point towards a date some time after 700 BC. (Figs. 41 and 42).²⁵³

The earliest Boiotian plate fibulae are MG II; plate fibulae with figure decoration of more than one figure began shortly after 725 BC, a date which is provided by one of the latest fibulae with a single figure from a securely dated tomb context at Lerna.²⁵⁴ Most likely all the examples from the Argive Heraion belong to the two quarter centuries on either side of 700 BC.

K. DeVries considers the Lerna fibula a Boiotian import, but B. Philipp compares it with AH 867 and 868 and a Tegean fibula and shows that about 40 of the then known LG fibulae came from the Peloponnese, compared to 70 from Boiotia and 30 from other regions outside Central Greece. She considers the existence of a Peloponnesian production quite possible.

The remaining Argive Heraion fibulae of the type are badly preserved but may, as suggested by Phillip, be connected with the Lerna fibula and several other fibulae from the Peloponnese which include a considerable number from Arcadia. I agree with Philipp in her attribution of these fibulae to a Peloponnesian workshop.²⁵⁵ The Blegen fibula is isolated stylistically but it may be just a late example of the same class as the other AH fibulae.

However, I cannot accept the attribution to the Argolid, advanced by Kilian, Philipp and other scholars, of the greater part of the above fibulae as well as of two other bronzes with stylistically related engraved decoration. One is the Tegea disk where a goddess holding poppies is standing on the back of an animal and with a large bird to her right. The other is the bronze horse in Bonn with an engraved bird on its neck. For the former object I follow Voyatzis in regarding the disk as a local Tegean work and the stylistically related engraved fibulae as Arcadian; the horse statuette I cannot see as an Argive work, although I fully agree with the view that its engraved decoration is stylistically related to that of the above bronzes.²⁵⁶ Considering that the very varied Arcadian Geometric bronze work found inspiration in many Greek regions, I regard an Arcadian workshop for the fibulae and the other objects with similar engraved decoration as much more likely than an Argive one.²⁵⁷

Most Argive Heraion fibulae were imports, which like several other groups of Greek Geometric bronzes at this sanctuary, showed connections in particular with Thessaly, Central Greece and Arcadia. The insular types of fibulae have been mostly shown to be either Thessalian or Arcadian variants, apart from a few fibulae with a wide distribution area. Judging from the plate fibula of specific character, AH 879 of Thessalian type, there may have been a limited local fibula production at the Argive Heraion around the year 700 BC and, if so, it presumably also produced simpler fibula forms as e.g. some of the arched fibulae.

Neighbouring votive deposits

The few fibulae from neighbouring deposits are, with one exception, of types known from the Argive Heraion. In the Hera sanctuary west of the Heraion was found a fibula with a leaf-shaped bow and incised decoration of crossed lines (Fig. 35). The fibula type had its origin in the Submycenaean Period, but lasted into the Archaic Period with a large distribution area, including Thessaly, Epirus and the Peloponnese as well as Southern Italy.²⁵⁸ At the same sanctuary were two simple arched fibulae besides a large one of twisted rectangular wire of the same type as AH 844 - 845. (Fig. 35).²⁵⁹

A violin fibula type with two small rivets for a decorative addition in another material is known from the votive deposit of Prosymna Tomb XXVI and the leaf-shaped bow with incised decoration of a large Boiotian plate fibula from Tomb IX (Fig. 36). It has incised lines along the edge and six such lines follow the longitudinal axis.²⁶⁰

Argos

In the Late Geometric/Early Archaic sanctuaries of Argos there are several examples of the same Greek Geometric fibula types represented at the Argive Heraion.

In the Athena sanctuary on top of the Larissa hill were several arched fibulae, e.g. Vollgraff Br. 1855, without specific characteristics, and B 67 and B 68, the former with a triangular catch, the latter with a twisted arch (Figs. 32 and 43) and one with twisted arch and triangular catch like AH 844 - 845 (Fig. 43).²⁶¹ One more arched fibula comes from the Aphrodision, No. 72/1013; thus its absolute date is presumably Archaic.²⁶²

Also the violin type fibula with rivets for fastening an ivory or bone plate is represented at the Athena sanctuary, B 22 (Fig. 43) and in the same sanctuary were two fragmentary spectacle fibulae of bronze, Vollgraff Br. 1855.²⁶³

Fig. 43. Argos. Museum.
Athena Sanctuary. Larissa.
Fibulae and pins. Photo Ecole
Francaise d'Archéologie,
Athènes. Neg. no. 22649.

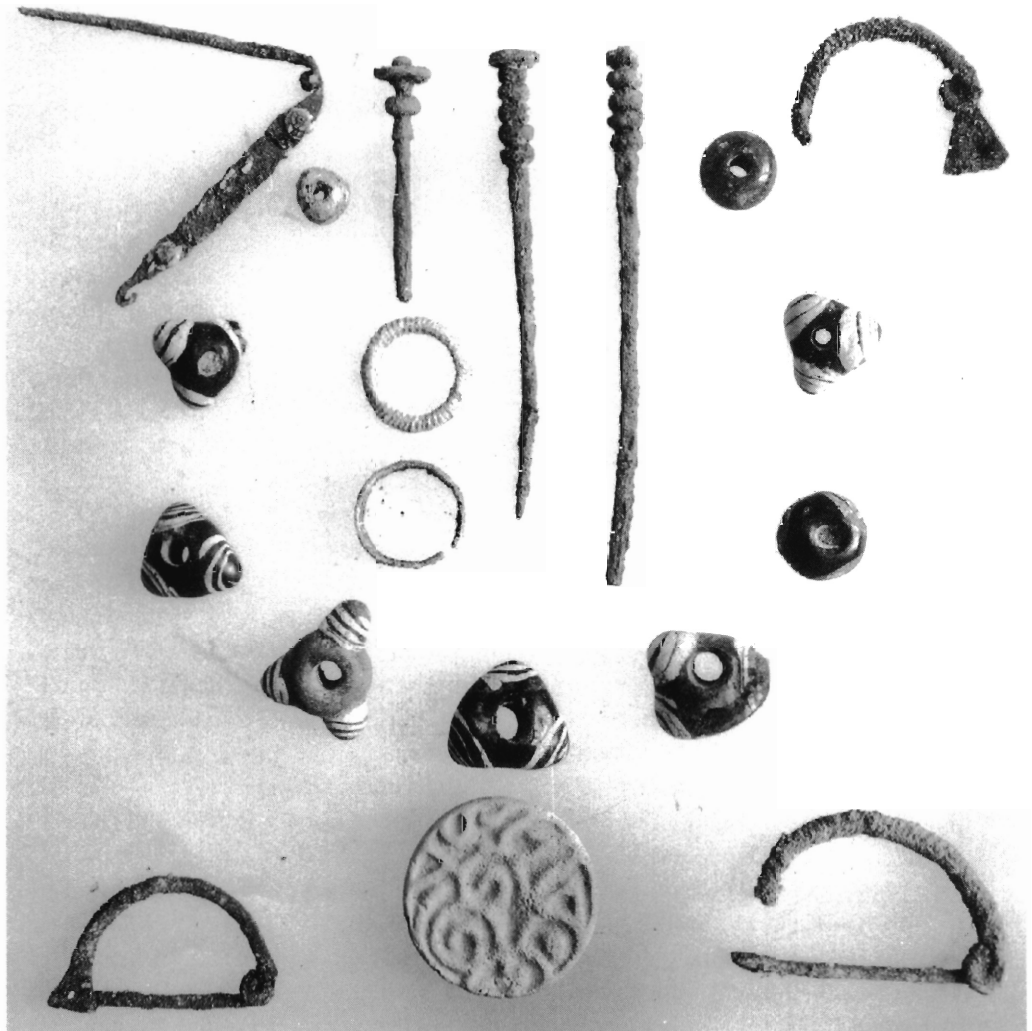

From Vollgraff's excavations of the Athena sanctuary come an Thessalian type plate fibula and two insular plate fibulae. Vollgraff Br. 1854 is well preserved; the arch has a central globe with a rather large double-conical globe on either side and its plate ends above in a small cylindrical knob. Its closest counterparts are found in Blinkenberg Group VII 8; presumably it is a Peloponnesian variant of a Thessalian fibula. The two insular plate fibulae are without counterparts at the Argive Heraion. They both belong to Blinkenberg, Group IV. One, Br. 1855, is very close to some fibulae from Schiff's tomb on Thera of Blinkenberg Type IV 11 and has counterparts also at Tegea. It is well preserved, only the end of its plate is broken; it has a central globe between two double-conical

rings. Of Br. 1854, only a fragment of the centre of the arch is preserved, of a triangular, almost pyramidal form with two rings originally on either side; it is closely related to a fibula from Crete of Blinkenberg's Group IV 2, as well as to one of the two fibulae of this type found at Olympia. This type of insular plate fibulae is rare in Mainland Greece. All the above plate fibulae from Argos may be Late Geometric or Early Archaic.²⁶⁴

There are MG/LG fibulae in Argive Geometric tombs, including Boiotian plate fibulae (of which there possibly also was a small fragment in the Athena sanctuary), and there are a few fibulae at other sites in the Argolid.²⁶⁵

As regards the fibulae, there seems to be some correspondence in finds between

the Argive Heraion and Argos. Nevertheless, among the few fibulae from sanctuaries at Argos, two are of an insular type not represented in the large body of material from the Argive Heraion and rare in the Greek Mainland with the exception of Arcadia and Olympia.

Pins

This part of my work can hardly be more than a summary of the results of the extremely thorough study of Greek bronze pins in the Peloponnese by I. Kilian-Dirlmeier.²⁶⁶

The bronze pins which fastened the woman's peplos in Attica as well as in the Peloponnese from the Submycenaean Period onwards and which were also used for male dress, were rare outside the Greek Mainland.²⁶⁷ In the tombs they were found singly, in pairs or in rather large numbers, but we know very little of the way in which they were offered in the sanctuaries.²⁶⁸

The Argive Heraion

There are offerings of pins in hero cults as well as in sanctuaries of male gods, but they are most abundant in sanctuaries of goddesses. As pointed out by K. Kilian, pin offerings greatly outnumber fibulae in four Greek sanctuaries, all of which are Peloponnesian: the Artemis Orthia Sanctuary at Sparta, the Athena Alea Sanctuary at Tegea, the Heraion of Perachora and the Argive Heraion. At the lastmentioned site, 110 bronze fibulae were found as compared with between 700 and 800 pins of ordinary size and more than 2,000 of the so-called "spits". Only in one case do we know that the pin was made as a specific dedication to Hera. Probably some of the pins had actually been in use before being offered.²⁶⁹ The pins were found all over the sanctuary.

I. Kilian - Dirlmeier observed that the earliest pins at the Argive Heraion were of Protogeometric types and might be taken as evidence of votive offerings in the early Post-Mycenaean Period.²⁷⁰ The two Pro-

togeometric pins offered at the Argive Heraion were both of Kilian-Dirlmeier's Type B, decorated with a large globe and an upper end disk, in one case partly of iron.²⁷¹ It is this pin type which develops into the earliest Geometric pins, classified by Kilian-Dirlmeier as Geometric I.²⁷²

The Geometric pins which Jacobsthal divided into three main groups were classified by Kilian-Dirlmeier into more than 20 groups, of which several again were divided into subgroups, Geometric I thus into I A - I D.²⁷³ Like Protogeometric B, Geometric I is decorated with a globe and an end disk and it has a small decorative part above the disk.

Geometric I A is simple without any rings on either side of the globe; both shaft and stem (between globe and disk) are round. The type is known all over Central Greece and the Peloponnese with examples also at the Argive Heraion. As immediate typological development of Protogeometric pins, it reaches back into EG; it is well known in MG and lasts into LG.²⁷⁴

Geometric I B is characterized by differences in the sections of the upper part of the shaft and stem; when one part is round in section, the other is quadrangular. There are closed EG tomb contexts at Mycenae and the type apparently does not continue after MG. There are relatively few examples known, four of which were found at the Argive Heraion; of these, three have tremolo decoration at the upper part of the shaft. Geometric I B is known also from other sites in the Argolid as well as from Corinth and Perachora, Delphi, Olympia, Sparta and Tegea.²⁷⁵

Geometric I C has a quadrangular or hexagonal section of the stem. It covers both the MG and the LG periods and, judging from its distribution area, it seems to be essentially a Corinthian type, although it is also represented in Central Greece. There are a few examples in the Argolid, one pin at Tiryns and three at the Argive Heraion.²⁷⁶

On the other hand, Geometric I D with a quadrangular stem and a round shaft which changes just below the globe

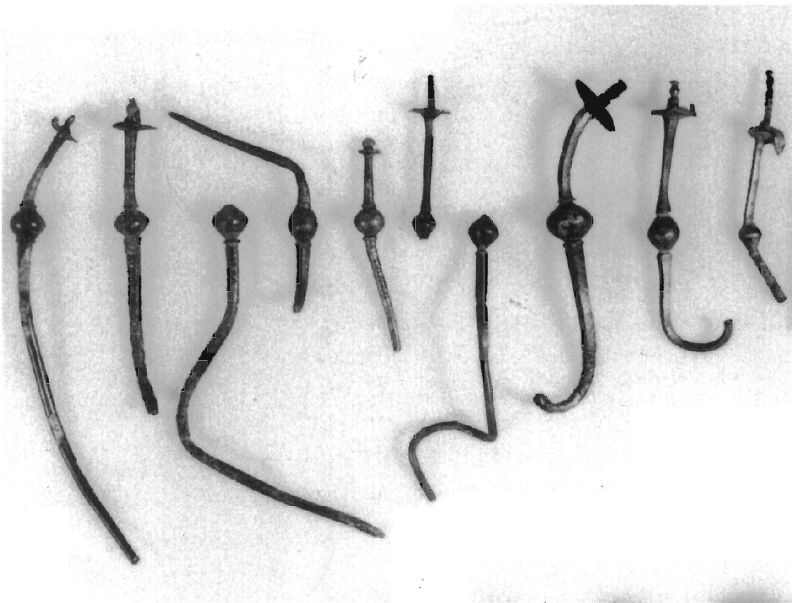

Fig. 44. Athens. National Museum. Pins. Geometric I. Argive Heraion. Photo American School of Classical Studies, Athens.

into a rhombic or quadrangular section, often with tremolo decoration, is extremely favoured at the Argive Heraion (with about 350 examples) as well as elsewhere in the Argolid and the Corinthia. There are datable contexts in the EG Period, and the type continues into LG, with an overwhelming majority of finds in the Northeast Peloponnese where it must have been locally manufactured, probably at several sites. However, there are finds in the sanctuaries of Arcadia and Laconia, as well as one specimen from Messenia and one from the island of Aigina. It is possible that a corresponding production took place on Rhodes (LG finds at Lindos and Ialysos). It is worth noting that it does not appear to be found at Olympia. (Fig. 27 (Geometric I D, Centre) and Fig. 44 (Geometric I A, C and D).²⁷⁷)

Geometric II has two globes separated by plain elements, the upper globe as a rule larger than the lower one. Kilian-Dirlmeier sees her pin class Geometric II, for which she also has several subgroups, as an intermediary between Geometric I and III; but there are no datable contexts. Less than 20 examples were found at the Argive Heraion and a few others at other sites in the Argolid, the Corinthia and on Aigina. There are some Geometric II pins from Laconia and many from Arcadia, in particular Tegea with between 20 and 30

pins. This distribution pattern suggests an Arcadian production.²⁷⁸

Geometric III with three globes has a wide distribution area. Geometric III A 1 consists of only one pin from Olympia, whereas pins of Geometric III A 2 were found almost over the whole of the Peloponnese, although with only a few pins at most sites except for the Corinthia and the Argive Heraion. There is only one fragment at another site in the Argolid, Tiryns, and a few examples outside the Peloponnese. The chronology of Geometric III is MG and LG, lasting into the 7th Cent. BC. By far, the greatest number of Geometric III pins come from the Argive Heraion which, as observed by Rolley, is also the only certain provenance for two of the subgroups, Geometric III A 3 (Fig. 46, AH 2623) and III B. Kilian-Dirlmeier localizes the production of Geometric III to the Corinthia where there are five examples of III A 2 at Perachora as well as about a dozen from Corinth, including three tombs with two or more pins. For subgroups III A 3 and III B, I consider a local production at the Argive Heraion as most likely, possibly influenced by the Corinthian production of III A 2.²⁷⁹

The following four groups, Geometric IV, V, VI and VII, are decorated with several globes, the first with four, the second with five and the last two with one large central globe and either three (Geometric VI) or four (Geometric VII) smaller globes both above and below it. All four types have a very limited production. Geometric IV is represented by only one pin in each of the sanctuaries: Athena Alea at Tegea, Artemis Orthia at Sparta, the Heraion of Perachora and the Argive Heraion.²⁸⁰ Geometric V was apparently produced throughout the 8th Cent. BC., but in limited numbers. The largest group (11 pins) is at the Argive Heraion, several of which have tremolo decoration (Fig. 46, AH 2631 and AH 2633). There are only a few examples at Corinth, Perachora, Olympia, Sparta, Tegea, Delphi and Samos²⁸¹ Of the known six examples of Geometric VI, one comes from the Argive Heraion and one from the Hera sanctuary west of

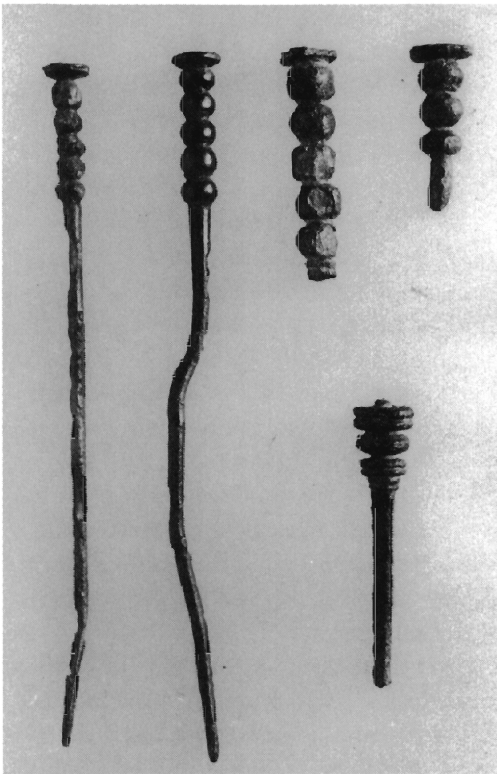

Fig. 45. Athens. National Museum. "Mehrkopfnadeln". Argive Heraion. Photo American School of Classical Studies, Athens.

it, two from Olympia and two from Perachora. Like Geometric IV - V, they are not found outside the Peloponnese. They are dated to LG and the 7th Cent. BC.²⁸² Geometric VII consists of only two pins, both from Perachora.²⁸³ A great number of fragments which cannot be exactly classified within the groups Geometric II - VII were found at the Argive Heraion (Fig. 46).²⁸⁴

In Geometric VIII - XI, the elements of construction do not form separate parts, but only differentiated details of head and shaft, and the same applies to Geometric XII which also has a reduced disk (Fig. 27 above, Geometric XI, and right, Geometric XII). They are chiefly found in Laconia and Arcadia and must be of Central Peloponnesian manufacture. Most pin types are dated to the second half of the 8th Cent. BC. and the 7th Cent. BC. There are limited finds outside the Central Peloponnese, in the Corinthia, including Perachora, at Tiryns, Olympia and Delphi and on Samos and,

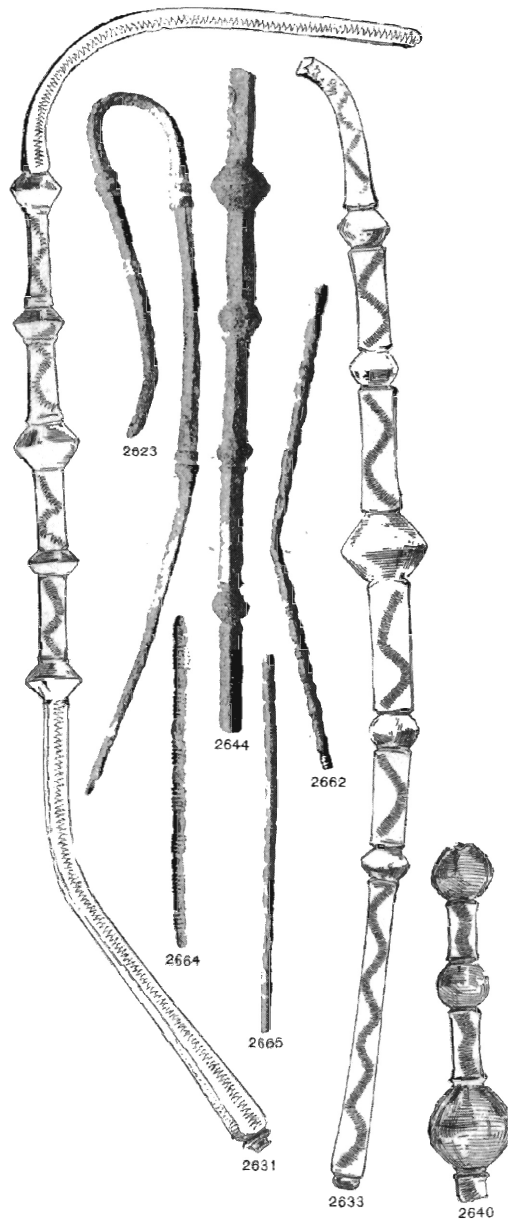

Fig. 46. So-called "Spits". Drawings. From AH II, pl. CXXXII.

except for Geometric X, each group is also represented at the Argive Heraion.²⁸⁵ Geometric XIII - XV, of the same general type and also with reduced disks, must be Central Peloponnesian, too. Only Geometric XIII is represented at the Argive Heraion (with two pins), while there is one fragment of Geometric XV at Tiryns. Of the LG Geometric XVI, also Central Peloponnesian, there are about 15 examples at the Argive Heraion. Geometric XVII is, apart from a single find at Tiryns,

known only from Arcadia where its centre of production must have been.²⁸⁶ One pin fragment from the Argive Heraion cannot with certainty be attributed to either of the classes, Geometric XII - XVII.²⁸⁷

Hammer pins, Geometric XVIII, some of which had iron heads, were found in tombs of Argos in a gradual development from EG to LG and presumably continued into the 7th Cent. BC. The later pins were decorated with larger side disks. Undoubtedly, they are products of Argos. There are several examples at Tiryns, one at Corinth and some at Tegea, but they seem to be absent at many Peloponnesian sanctuaries, as e.g. Olympia, Artemis Orthia at Sparta and the Heraion of Perachora.²⁸⁸ There are about 30 hammer pins at the Argive Heraion, although not of the type XVIII A which is found only at Argos and possibly was the earliest of this type. Most examples at the Argive Heraion belong to XVIII C (Fig. 27, left).²⁸⁹

On the other hand, the following groups are rare at the Argive Heraion. Of Geometric XIX with a conical head, presumably Arcadian and also lasting into the 7th Cent. BC, there are only a few finds at the Argive Heraion and one at Tiryns.²⁹⁰ Neither Geometric XX, the so-called flat head pin, nor Geometric XXI are represented at the Argive Heraion. The latter is a West Peloponnesian type, not known from the Argolid at all.²⁹¹ Some pins at the Argive Heraion are of types not immediately classifiable in the above groups.²⁹²

Of the remaining Geometric pin types, the so-called "Mehrkopf-Nadeln" (Jacobsthal Group III) with a vertical row of beads were found in almost all Peloponnesian regions as well as in Northwest Greece including Ithaca, at Delphi, on Aegina and in the Western Greek colonies. Their date seems to be the second half of the 8th - 7th Cent. BC. They were found in most Peloponnesian sanctuaries and were especially popular at the Argive Heraion where they number more than 200, as well as at Sparta. According to I. Kilian-Dirlmeyer, her types A and C -D had a widespread distribution, including both major finding places, the Argive

Heraion (Figs. 27 and 45) and Sparta. Her variants B and E - G were found only at Sparta, H and I almost exclusively there except for a few examples in other Central and Western Peloponnesian sanctuaries. Type K comprised different pin types, which were mostly found in Laconia but were represented also at the Argive Heraion, Perachora and in Arcadia, while variant L, mostly found in Laconia and at Olympia, is represented by only one find at the Argive Heraion and one in Achaia. The more widely distributed groups (A and C - D) may have been manufactured at the Argive Heraion as well as at other sites; the variants of presumably Laconian manufacture (B and E - I), however, were not represented at the Argive Heraion, at all.²⁹³

The so-called "Pilzkopf-Nadeln", presumably also a Laconian product of the Late Geometric and Early Archaic Periods, are among the few Geometric pin types not represented at the sanctuary of the Argive Heraion.²⁹⁴

Not all roll pins, were recorded by Kilian-Dirlmeyer, apparently because of the difficulty in distinguishing Geometric/Archaic pins from earlier and later ones.²⁹⁵ However, roll pins are known from Greek sites without any Mycenaean connections and there are a few roll pins at the Argive Heraion.²⁹⁶

Neighbouring Votive Deposits

At the Hera sanctuary west of the Heraion, there are examples of the following classes of Geometric pins: Geometric I D, Geometric VI, a hammer pin Geometric XVIII and three "Mehrkopf-Nadeln" (Types A and C), all types represented also at the Argive Heraion.²⁹⁷

Of the few pins from votive deposits in the Mycenaean tombs around the Heraion only two are of Geometric type; one of the so-called "Mehrkopf-Nadeln" (Type C) was found in Tomb XL and a so-called "Pilzkopf-Nadel" in Tomb IX (Fig. 36). Apart from this pin, one in Olympia and a few in Messenia, all pins of the type come

from Laconia. According to Kilian-Dirlmeier the first two are not Laconian; however, she offers no evidence for her conclusions, and at any rate, their manufacture must be under Laconian influences. This pin type is not represented in the large collection of pins at the Argive Heraion.²⁹⁸ In contrast with the many pin offerings in the Argive Heraion, the votive deposits in neighbouring Mycenaean tombs give the impression of a different tradition with only two Geometric pins, one of which is a type foreign to the collection at the Hera sanctuary.

Argos

In the sanctuaries of Argos, pins do not appear in such overwhelming numbers as at the Heraion of Argos. Apart from a few examples from Vollgraff's excavations of the Athena Sanctuary on top of the Larissa hill and some fragments of Geometric type, but presumably of later date, in the Aphrodision, they are all listed in Kilian-Dirlmeier's publication. As the bronzes from the sanctuaries in Argos do not precede the Late Geometric Period, insight into the pin material from Geometric Argos must be sought also from the tomb finds. In the Geometric tombs of Argos, pins continue from Submycenaean - Protogeometric types. To a certain degree pins of both sanctuaries and tombs at this site represent the same classes as at the Argive Heraion. There are, however, also differences.²⁹⁹

Of Geometric pins, there are examples of Geometric I A as well as I B in Argos tombs, but not of Geometric I C, which is basically a Corinthian type with a few examples in the Argolid, one at Tiryns and three at the Argive Heraion. By far the most common Geometric I pins in the tombs of Argos were Geometric I D, also well represented at the Argive Heraion. Definitely a Northeast Peloponnesian product, it may well have been manufactured at both sites, Argos and the Argive Heraion.³⁰⁰

According to Kilian-Dirlmeier, one fragment of an iron pin from a tomb be-

longs to Central Peloponnesian, possibly Arcadian Group Geometric II, which also had a limited presence at the Argive Heraion.³⁰¹

Geometric III, of Northeast Peloponnesian, primarily Corinthian manufacture with one, possibly two subgroups presumably having been produced at the Argive Heraion, is as far as I know not represented in Argos,³⁰² nor are the rather limited groups of Geometric IV - VI, with a few finds at the Argive Heraion.³⁰³

The Central Peloponnesian groups, Geometric VIII - XII, of which a few were found at the Argive Heraion are not known from Argos, nor is Geometric XIII, also not well represented at the Argive Heraion.³⁰⁴ Geometric XIV - XV and Geometric XVII were found neither in the Argive Heraion nor in the sanctuaries of Argos,³⁰⁵ whereas at both sites there are a few examples of Central Peloponnesian Geometric XVI pins. Two of the three Geometric XVI pins from Argos come from the Athena sanctuary on top of the Larissa (Fig. 32) and there seems to be another fragment in the Aphrodision.³⁰⁶

On the other hand, as regards Geometric XVIII, the hammer pins, it is in Argos that we see their gradual development throughout the Geometric Period and down into the 7th Cent BC and, from the LG Period, in the sanctuaries (Fig. 32 left). The production of pins, Geometric XVIII, must be located in Argos, whereas one of the subgroups, Geometric XVIII A, probably the earliest, is not represented at the Argive Heraion at all.³⁰⁷

Of Geometric XIX, with three examples at the Argive Heraion, there are five pins from tombs in Argos and possibly a few fragments from the Aphrodision.³⁰⁸ Geometric XX, the flat-head pin, was not represented at the Argive Heraion, but there are several finds elsewhere in the Argolid (Mycenae, Tiryns) as well as in Argos itself (tomb finds from MG II onwards). According to Kilian-Dirlmeier there was a production centre in Argos as well as in Arcadia.³⁰⁹

The so-called "Mehrkopf-Nadeln"

which were found in large numbers at the Argive Heraion are also frequent in Argos, in tombs as well as in sanctuaries, and in general comprise the same subtypes (Types A, C and K) (Figs. 32 and 43).³¹⁰

Both at the Argive Heraion and at Argos we have a continuous development of bronze pins throughout the Geometric period and lasting into the following centuries. Foley's observation of differences between pin types in the tombs and sanctuaries of Argos in the 7th Cent. BC do not apply to the Argolid in LG, the only Geometric phase where we have comparative material from the Argos sanctuaries. In several cases pin types known at the Argive Heraion were included in the burial equipment at other Northeast Peloponnesian sites and this explanation cannot be used for differences between the pin types at the Argive Heraion and Argos.³¹¹

Comparing the pin types found at the Argive Heraion and in Argos – for the earlier part of the Geometric period in tombs only, from LG onwards also in the Argos sanctuaries – one observes a certain correspondence in the material of the two sites, as regards the more general Peloponnesian types such as Geometric I A and the so-called “Mehrkopf-Nadeln” as well as some Northeast Peloponnesian pin types, e.g. Geometric I D. It is no wonder that the large body of material at the Argive Heraion is so much more varied, while some types represented here are absent in Argos, as e.g. Geometric IV – VI with a very limited production or the Central Peloponnesian types of Geometric VIII – XII. However, when it comes to some Northeast Peloponnesian types, there are striking differences. For example, the MG/LG Corinthian pin types, Geometric I C and Geometric III (presumably manufactured in the Argive Heraion as well as in the Corinthia) both appear to be absent in Argos. On the other hand, early hammer pins, Geometric XVIII A, were found in Argos only, not in either the Argive Heraion or the Corinthia, and in the very large collection of pins at the Argive Heraion there is not a single fragment of the flat-head pins, Geometric

XX, which were apparently manufactured in Argos as well as in Arcadia.³¹²

From the Geometric pin finds, especially the local Northeast Peloponnesian manufacture of more specific types, one gets a clear impression of differences between the two sites chiefly studied here as well as of closer connections between the Argive Heraion and the Corinthia than between that sanctuary and Argos.

In other respects, both sites seem to be part of some of the same traditions common in the Peloponnese, although particularly favoured in the Northeast Peloponnese. In Peloponnesian sanctuaries as well as tombs were found very long pins, which may be undecorated simple pins, pointed at both ends, or may belong to the above pin types, primarily Geometric I A and I D and Geometric III – VI, the so-called “spits”, often showing tremolo decoration (Fig. 46).³¹³ They generally measure 30 – 40 cm. or more, the longest known examples from the Argive Heraion even in their fragmentary state, measuring around 80 cm.³¹⁴ Although definitely of ordinary pin types, such very long pins could probably not be used for the customary fastening of the peplos on each shoulder. In the tombs of the Argolid they are sometimes placed crosswise in tubes and in the Corinthia they were in a few instances found alongside the body, perhaps as a separate offering. A few such tubes were found at the Argive Heraion.³¹⁵ As suggested by Courbin, the pins placed in tubes may in the tombs have been used for the shroud and, in the sanctuaries, were perhaps sometimes offered in an analogous way.³¹⁶ For long pins in the sanctuaries, Jacobsthal suggests a ritual character, Kilian-Dirlmeier a representational one, whereas Foley distinguishes between long pins of type Geometric III for which she re-introduces the term “spits” and the actual function of roasting meat, and Geometric I D which she believes were meant especially for the cult statue.³¹⁷ I am inclined to agree with Jacobsthal or Kilian-Dirlmeier and do not find either of Foley's suggestions convincing. Jacobsthal had already given good

arguments against the former theory and as regards the latter there is no evidence that the find spots of the long pins include the Old Temple Terrace, where the cult statue was placed in the Archaic Temple. Apart from a few long pins in the Altar Area, the majority come from the West Building and the Southern Slope or the Back of South Stoa.³¹⁸

Although present in tombs, I do not know of any certain finds of long pins in the sanctuaries of Argos. However, another tradition connected with the offering of pins seems to characterize the sanctuaries of Argos as well as the Argive Heraion and other Peloponnesian sanctuaries: often the pins were bent, not just in the wellknown single bend of the shaft meant for hindering further use (Figs. 27, 32 and 44 - 46),³¹⁹ but into various complicated ornaments such as loops and spirals. For example, one of the pins from the Athena sanctuary on the Larissa formed a double loop, another a quadrangle with small spirals along the edges, a specific type not found at the Argive Heraion but which apparently had close parallels in Arcadia.³²⁰

G. Other Objects

The Argive Heraion

Among the Argive Heraion bronzes there are no vases of secure Geometric date, although it is possible that the Protocorinthian pyxis and skyphos fragments reach back into the late 8th Cent. BC.³²¹

There are a few remnants of Macedonian horse trappings and fragments of carriages, but like most implements and instruments, they are presumably to be dated after 700 BC³²² and the same probably applies to the few fragments of spears.³²³ There are no Geometric votive finds of definitely military character, although one fragmentary object, AH 2737 (NM 13990), is very close to the Geometric shield or belt buckles, well known, in particular, from Olympia. It shows, however, no trace of an internal ring fastening nor any circle ornamentation like the Geometric buckles.³²⁴

Bronze sheet with tremolo decoration

is very common at the Argive Heraion (AH 1779 - 1793). It varies in length from 4.5 - 6.6 cm. and may have a raised central axis; in many cases, the sheet has been bent along the edges, thus presumably serving as a coating for objects in a different material. Two more objects show tremolo decoration (AH 1847 - 1848). In the publication they are described as leaves. They have a raised central axis and a small tang and were decorated on both sides; apparently, they were cast and afterwards hammered.³²⁵

Neighbouring Votive Deposits

The Hera sanctuary west of the Heraion as well as some of the votive deposits of the Prosymna tombs yielded examples of Protocorinthian skyphos and pyxis types. One kind of bronze vase not represented at the Argive Heraion or the neighbouring small Hera sanctuary was found in the votive deposit of Prosymna Tomb XL, the so-called "Kalotten-Schale" (Fig. 47). Presumably of Cypriot origin, the bowl has a very early development in Greece having been found throughout the Geometric Period in tombs of Argos.³²⁶

Argos

I do not know of any Geometric bronze vases from the Argos sanctuaries, but the Argos tomb finds differ from those of the Argive Heraion and the neighbouring small votive deposits in the apparent absence of the Protocorinthian skyphos and pyxis types. The most common bronze bowl is the so-called "Kalotten-Schale", unknown at the Argive Heraion although found in one of the Prosymna votive deposits.³²⁷

There are examples of the use of tremolo decoration at Argos; but apparently no bronze sheet with this ornamentation was found in the Geometric sanctuaries of Argos. I do not know of exact parallels for one large flat bronze ornament (Fig. 32, Upper Row, Centre), but it somewhat resembles an ornament from Thermon -



Fig. 47. Prosymna. Tomb XL. "Kalottenschale". Photo American School of Classical Studies, Athens.

which Kilian connects with votive swords from Tegea and Sparta.³²⁸ In the Athena sanctuary on top of the Larissa as well as at the Aphrodision were found votive arrow heads, a type which is also known from Tegea, but not paralleled at the Argive Heraion or neighbouring votive deposits.³²⁹ Although it is a well known fact that local bronze manufacture at Geometric Argos specialized in weapons and armour, a bronze cuirass and several helmets having been found in Geometric tombs of Argos,³³⁰ there are no such votive dedications in the sanctuaries of Argos apart from the above-mentioned bronze arrows.

For this group of varied objects, the differences between the Argive Heraion and Argos appear chiefly to be connected with the divergent specialization of local Geometric bronze production at the two sites. It is not surprising that objects of military character were not considered appropriate dedications at the specifically female sanctuary of the Argive Heraion and, apart from votive arrow heads, such dedications were apparently absent also in the local sanctuaries of Argos. On the other

hand, not only votive arrow heads, but also miniature weapons and shields are known from Arcadian sanctuaries, including the Artemis sanctuary at Lusoi and the Athena sanctuary at Tegea.³³¹ It is worth noticing, however, the differences in vase types; Corinthian vase forms apparently were not being produced or imported in bronze to Argos and there seems to be a complete absence at the Argive Heraion as well as at the neighbouring small Hera sanctuary of the favoured Argos bronze bowl, the so-called "Kalotten-Schale". Its appearance in one of the votive deposits of the Prosymna tombs cannot be used to infer dedications to Hera.

H. Conclusions

In concluding my study of Greek Geometric bronzes at the Argive Heraion, a chronological division into three main phases seems appropriate. The first covers the initial Post-Mycenaean phase, not actually included in this study, until about 800 BC (PG/EG/MG I); the second is, in general, equivalent to MG II, lasting until

ca. 750 BC, and the third extends into the early 7th Cent. BC (LG/Subgeometric).³³² For the first two phases, the study material is very restricted and since the Argos sanctuaries have not yielded any bronzes definitely earlier than the LG Period,³³³ the tomb contexts of Argos must supply the comparative material.

Only two bronze pins at the Argive Heraion are of PG types, but it is suggested that they may be later dedications,³³⁴ and definite evidence of a possible Post-Mycenaean cultic activity at the site before 900 BC will presumably have to wait for the publication of the early Post-Mycenaean pottery.³³⁵

During the 9th Cent. BC (EG/MG I), pin offerings continue in increasing numbers and still constitute the only certain bronze remnants at the site. Pin types, Geometric I and XVIII, all begin in this period, Geometric I C during MG I, the others already in EG. Geometric I A pins were found all over the Peloponnese, while Geometric I B and the much favoured type, Geometric I D, are of Northeast Peloponnesian manufacture, found in the Corinthia as well as in the Argolid, including the settlement of Argos. On the other hand, both Geometric I C and Geometric XVIII, the hammer pins, have a limited distribution area. Only four examples of the former type, which seems to be of Corinthian manufacture, were found in the Argolid, three at the Argive Heraion and one at Tiryns; it is not recorded from Argos. The hammer pins were definitely manufactured at Argos. One of its types, Geometric XVIII A, possibly the earliest, has been found only in tombs of that settlement, while Geometric XVIII B - C are found at the Argive Heraion as well as at Tegea and Geometric XVIII C also at Tiryns and in the Corinthia.³³⁶

With the presence at the Argive Heraion of PG as well as EG pins, I see no reason to doubt that the sanctuary existed at least as early as the first half of the 9th Cent. BC and possibly, although not definitely, even earlier.³³⁷ In spite of its limited character, the material from this period shows a definite tendency in its distribu-

tion; the pins of specific Corinthian origin reach only the Argive Heraion, not Argos, whereas the typical Argos pins in the beginning seem to be restricted to that site alone, not finding their way to the Argive Heraion or other sites in the Northeast Peloponnese. Neither at the Argive Heraion nor at Argos do the bronze finds indicate relations outside this region.

In the course of MG II, the first half of the 8th Cent. BC., the above pin types continue, while Geometric III and possibly also the Central Peloponnesian pin type, Geometric II, make their first appearance. Of the latter group which has a comparatively good representation at the Argive Heraion, there may be one fragment from Argos. Of the former, however, the production of which is primarily Corinthian with a probable secondary production at the Argive Heraion, there is not a single example elsewhere in the Argolid, including Argos. As Geometric III A pins were found in the Corinthia in tombs as well as in sanctuaries, the difference in their distribution pattern in the Argolid cannot be due to different traditions for votive dedications and burial equipment.³³⁸

During MG II, there is definitely one tomb in Argos with Geometric XVIII B pins, a type which is also found in the Athena sanctuary on top of the Larissa as well as at the Argive Heraion. Whether the examples in the sanctuaries are MG II or LG is difficult to tell.³³⁹

The flat-head pins, Geometric XX, which were produced in Argos as well as in Arcadia, begin in MG II. Because of their lance-shaped head, their function has been disputed; but Kilian -Dirlmeier regards them as pins. At any rate, in spite of a local manufacture at Argos and finds also in Tiryns and Mycenae, they are not among the pins offered at the Argive Heraion.³⁴⁰

The bronzes at the Argive Heraion now show more variation than formerly, possibly including other kinds of personal ornaments as well, e.g. some arm rings and fibula types, but certainly the earliest tripods, the Solid Cast Tripods, Subgroup

II, which were not dedicated in any other Northeast Peloponnesian sanctuary.³⁴¹

The differences in the distribution pattern of the bronze pins, noted for the 9th Cent. BC, are still observable in the first half of the 8th Cent BC. The Argive Heraion continues its rather close relations with the Corinthia, relations which are not observable for Argos, and although both main sites, the Argive Heraion and Argos, have examples of Central Peloponnesian pin types, the specific types differ. At this time, the Argive Heraion appears to be the only Northeast Peloponnesian sanctuary of such importance that it has monumental tripods.

During the LG/Subgeometric Period, from around 750 BC until shortly after 700 BC, the Greek bronzes from the Argive Heraion reflect a rich and varied activity at the sanctuary: the types represent all kinds of personal ornaments, as well as vessels and animal figures; their origins give evidence of relations with many Greek regions; and the monumental tripods indicate the accelerating importance of the sanctuary.

The pins still constitute by far the largest group of items, surpassing in numbers those of all other sanctuaries. Most of the above pin types continue and with the same differences in distribution pattern. New types begin to appear, in particular, Jacobsthal's Group III, the Geometric so-called "Mehrkopf-Nadeln", the production of which lasts well into the 7th Cent. BC. The two main sites, Argos and the Argive Heraion, have almost the same pin types, Laconian types B and E - H are found at neither site, the more common types of A and C at both. Only type D, which was primarily found at Sparta, is represented at the Argive Heraion as well as at Mycenae and Perachora, but not at Argos.³⁴²

The very long pins apparently form a Peloponnesian, in particular, a Northeast Peloponnesian tradition, including the Corinthia as well as the Argolid and both main sites. Both sites also display examples of pins or wires bent into ornaments with loops, although the specific ornament

with an Arcadian parallel at the Larissa sanctuary does not have direct counterparts at the Argive Heraion.³⁴³

Visitors to the Argive Heraion apparently came from many Greek regions. There are Laconian horse figures, a few Laconian pin types and possibly also Laconian bird pendants, although they are more likely imitations of Arcadian origin. Connections further west in the Peloponnese are slighter; West Peloponnesian pin types, as e.g. Geometric XXI, are not represented in the Argolid at all. From Arcadia there are horses and bird figures as well as pendants, pins and fibulae. A few insular type fibulae may in fact also be of Arcadian origin. By far the closest relations with Arcadia seem to be with Tegea, where even bronze statuettes manufactured at the Argive Heraion were dedicated. Some pin types are of Corinthian origin as well as some animal figures and the most characteristic vase forms. From Central Greece come several bird figures, at least one horse figure, arm rings and possibly fibulae. The connections are particularly close with Kalapodi, while there is no certain presence of Athenian bronzes. It is not always possible to distinguish definitely between Central Greek and Thessalian bronzes, but there are undoubtedly Thessalian fibulae and bird figures and the Argive Heraion also has a large variety of Macedonian personal ornaments, arm rings, pendants and beads, and possibly also harnesses and carriages of Macedonian workmanship, although the fragments of these finds are probably of Post-Geometric date. Connections outside the Greek Mainland are few. The genuinely insular fibulae are of types which have parallels elsewhere in the Peloponnese and Central Greece and may not indicate direct relations with the Greek islands.³⁴⁴

The imported Greek Geometric bronzes found at Argos are considerably more sparse, and although in general they represent almost the same external connections, there are noticeable differences. Found in Argos are Central Peloponnesian, in particular, Arcadian pins and Arca-

dian pendants, in both cases also showing particularly close connections with Tegea. Nevertheless the Arcadian pin types are not always the same at the two Argive sites and even pendants of presumably Tegean origin may differ in type. There are in Argos Thessalian and Central Greek fibulae types corresponding with those in the Argive Heraion, but they are all of Peloponnesian origin: original Thessalian fibulae are not present in the Argos sanctuaries. In the necropolis was found a Central Greek bird pendant of a type different from those at the Argive Heraion. Neither Thessalian nor Macedonian bronzes were among the bronze imports in Argos. Although several finds show the same general lines of external relations, the differences in detail suggest that the two sites did not have ties with the same bronze workshops or the same groups of people in the various Greek regions.³⁴⁵

Apart from the above-mentioned bronzes there are in Argos also insular fibulae of types rare in the Peloponnese and not known from the Argive Heraion.³⁴⁶

It is no wonder that the Geometric bronzes at the Argive Heraion were so much more varied than those at Argos, but it seems worth noticing that the comparatively few Geometric bronzes known from the sanctuaries and the LG tombs in Argos comprise types not seen at the Argive Heraion, in spite of the overwhelmingly rich material at the latter.

From the bronzes characteristic of the various Greek Geometric sanctuaries, one gets the impression of a high degree of specialization. Most Peloponnesian regions had a production of specific pin types and Arcadia, for example, seems to have specialized also in pendants and animal figures, while to a large degree imitating other regions in the production of bird figures and fibulae. The sites and sanctuaries of Corinthia had an independent production of pins, vessels and animal figures, but apparently did not produce bird figures. In Central Greece and Thessaly we find a considerable number of local fibulae and bird figures as well as horse figures and arm rings.³⁴⁷ However,

during the LG Period, in particular, local bronze workshops do not appear to have been restricted to their original types, but invariably imitated and were subject to influences from other regions as well, making the general picture rather complex.

As far as the Argive Heraion is concerned, the manufacture of bronze statuettes of animals apparently did not start until late in the 8th Cent. BC, under various stylistic influences, of which those from Arcadian bronze workshops were not the least important. In spite of the finds of Laconian bronzes at this sanctuary, Laconian influences on the bronze figure production seem minimal; most Laconian type birds display Arcadian details. Although there was a Geometric production of human bronze figures at Argos, there is no evidence for such a manufacture at the Geometric Argive Heraion. Local pendants, fibulae and arm rings at the Argive Heraion are influenced by Macedonia, Thessaly, Central Greece and the Central Peloponnese, in particular Arcadia. On the other hand, apart from a single pin type, produced both in Argos and Arcadia, at Argos there are few examples of actual imitations in bronze of personal ornaments from other Greek regions. Most items seem to be imports.³⁴⁸

Some of the differences between the Geometric bronzes at the Argive Heraion and Argos concern the relations with two important Greek regions, Laconia and the Corinthia. During the LG Period, the differences are observable not only in pin types as earlier, but more generally in the locally produced objects under external influences. While the Argive Heraion continues its close relations with the Corinthia, seen at this date for example in earrings and vase forms, Argos appears to be more in touch with Laconia. It is difficult not to see the Argos warrior from Delphi as influenced by Laconian bronzes, in theme as well as style.³⁴⁹ That Corinthian influence never reached Geometric bronze work at Argos may be deduced from the absence of Protocorinthian vase forms among the Argos bronzes and it is presumably more than a coincidence that

the preferred Argos Geometric bronze bowl, the so-called “Kalottenschale” was found neither at the two Hera sanctuaries nor in the Corinthia.³⁵⁰

Also, as regards more specific objects locally produced at either site, there are dissimilarities. The Argos bronze weapons and defence armour were apparently not dedicated at the Argive Heraion, nor such votive weapons as bronze arrows of which we have examples in the Argos sanctuaries.³⁵¹ Although the LG horse figures at the Argive Heraion can be interpreted as chariot horses and thus a kind of status symbol, they are local works not symbolizing the status of the visitors from Argos and their types differ from that of the one bronze horse figure known from Argos.³⁵²

One gets the general impression that although the LG period was one of closer contacts between Argos and the Argive Heraion than the earlier phases, the two sites were still to a certain degree separated culturally. Not all inhabitants of Argos visited the Heraion and perhaps, in particular, not the upper class warriors and other wealthy males, whose burial equipment is well known today.

There remains the problem of the monumental bronze tripods. We see a continuous development of the type at the Argive Heraion throughout the greater part of the 8th Cent. and the early 7th Cent. BC, but we have not the least trace of it at the settlement of Argos. Whether, as suggested above, the monumental bronze tripods were acquired by order for use as *perirrhanteria*³⁵³ or were dedications by wealthy and powerful citizens or both, one should expect some remnants also in Argos, if the upper class inhabitants of this settlement were involved in their acquisition. One might perhaps argue that the Argive Heraion was considered the primary sanctuary of the Argolid, thus solely receiving such spectacular monuments. However, in neighbouring Corinth an LG bronze tripod was erected at the local Apollo Temple and if such a tradition were prevalent at Argos, one might expect it to include also local sanctuaries of the settlement.

The monumental bronze tripods were

apparently the work of itinerant artisans who probably included local bronze workers trained at the Argive Heraion. Judging from the classification by German scholars, the tripods made at the sanctuary of the Argive Heraion were apparently the works of artisans connected with the eastern regions of the Greek Mainland, who naturally also frequented Panhellenic sanctuaries. Apart from the tripods in Delphi and Olympia, the closest counterparts to the Argive Heraion LG bronze tripods were found in the Corinthia and Central Greece, especially Kalapodi.³⁵⁴ With the exception of Arcadia, from which region we still have no examples of monumental bronze tripods, this is a distribution pattern which corresponds well with that of other Geometric bronzes in the Argive Heraion. This sanctuary was very open to the east, the Corinthia and the eastern part of Central Greece, and not so much towards the south. Only during the LG Period do we find signs of continuous relations with Argos, however, judging from the bronze finds, associated with the more humble inhabitants. And although there is a certain similarity between the finds from both the Argive Heraion and Argos and those from Tiryns and Mycenae, the settlement of Argos apparently did not have much connection to areas over land to the east. This impression corresponds to that obtained from the pottery of Argos, which throughout the greater part of the Geometric Period was subject to influences from Attica; only at a late date and reluctantly was influence felt from Corinth.³⁵⁵

Although the interrelations between Argos and the Argive Heraion are considerably stronger during the LG Period than in previous centuries, one still gets the impression of two separate communities with different external connections, almost turning their backs on each other. Apart from Arcadia, Argos was open towards regions which might best be reached across the sea to the south, the islands, Laconia and Attica, and possibly via the last-mentioned region to other parts of Central Greece. The Argive Heraion was open landwards toward Arcadia in the

west and definitely over land to the Corinthia and Phocis in the east as well as to the north, Thessaly and Macedonia. In spite of their geographical proximity, the similarities in the votive bronzes of the two Argive sites are not very great and comparisons between the bronzes from Argos tombs and the Argive Heraion seem even to stress different traditions. The definitely military aspect of the Geometric bronzes in the upper class male tombs at Argos has no counterpart at the Heraion; probably its visitors from Argos were not generally included in this group of people. During the LG Period there were definitely many visitors from Argos to the Argive Heraion, but apparently not more than from other Mainland Greek regions and their votive offerings were for the greater part articles of women's dress of local and often rather humble manufacture. Dedications by those leading figures of Argos society whose burial equipment we are acquainted with are not easy to point out.

In recent decades, several scholars have advocated the theory that the Argive Heraion was founded as a sanctuary by Argos in the 8th Cent. BC. T. Kelly, who dates the foundation to the third quarter of the century sees such an event as political and religious, demonstrating the power of Argos over the Argive Plain and neighbouring cities.³⁵⁶ F. de Polignac stresses the importance of securing farming land and territorial rights, but also the military aspects of the deity. De Polignac's argumentation is complex and subtle, allowing for the possibility of Argos having raised an already existing sanctuary to importance and cultural significance; however, it cannot apply to the period studied here, i.e. before the early 7th Cent. BC.³⁵⁷ A recent article by two American scholars, C. Morgan and T. Whitelaw ascribes to Argos "the construction of the Argive Heraion ca. 725". Their theories are based largely on the Argive Geometric pottery. In my opinion, the Geometric pottery from the Argive Heraion cannot be used for general conclusions until at least a fair amount has been published.³⁵⁸

Both the two last-mentioned studies make use to a large degree of much later information about cult life at the Argive Heraion. But we have no evidence that such information reflects the situation at the Geometric sanctuary.³⁵⁹ More important to me are the results of the above investigations which do not support these theories: the bronze finds at the Argive Heraion indicate a very slow development of the sanctuary, from the early 9th Cent. BC, or even earlier, onwards. Its early contacts with Argos are remarkably slight, almost non-existent, and although increasing toward the end of the Geometric Period, they never surpass those of several other Greek sites. Throughout the Geometric Period, when the sanctuary gradually expands its outside relations, its closest contacts are with the Corinthia, not with Argos, whose own relations with the Corinthia during the same period are negligible. The evidence of the Geometric bronzes, the only contemporary archaeological evidence from the Argive Heraion which is extensively published, excludes the possibility of the sanctuary of the Argive Heraion having been founded as late as the 8th Cent. BC, and contradicts the theory of its having been either founded or significantly influenced and controlled by Argos during the Geometric Period. In my opinion, it even calls into question the idea of the Argive Heraion having been deliberately founded. The religious motives for beginning cultic activity at a site will not always be tangible and in its initial phases the Argive Heraion gives the impression of being a sanctuary of humble character, not of an organized foundation. Whether the annexation of the Argive Heraion by Argos, which is a fact, took place in a military action or by other means, the event must be placed after the period studied here, i.e. after the early 7th Cent. BC.³⁶⁰

Another theory advocated by some scholars sees the origin of the Argive Heraion cult as closely connected with the LG hero cults of the votive deposits in the neighbouring tombs, in one case even incorporating the small Hera shrine in the

argument.³⁶¹ The material from the two groups of neighbouring votive deposits, the Hera sanctuary west of the Argive Heraion and the deposits in the Mycenaean tombs surrounding the sanctuary belong to the period covering the last quarter of the 8th Cent. BC and the early part of the 7th Cent. BC.³⁶², i.e. several centuries after the first signs of votive offerings at the Argive Heraion and about half a century after the Argive Heraion had given evidence of wealth and of many and varied external relations.³⁶³ The interest in the Mycenaean tombs, therefore, cannot have been the cause of either the foundation or the rise of the Argive Heraion. More likely, the growing importance of the wealthy and long established sanctuary at the Argive Heraion drew attention to the neighbouring Mycenaean tombs, which then became subject to hero cults, a widely known phenomenon in the LG period.³⁶⁴

The sanctuary west of the Argive Heraion with a small terrace and presumably an altar is identified with a Hera cult from an Archaic inscription.³⁶⁵ It is situated 75 m. from the tholos tomb and 25 m. from the nearest chamber tomb, a position which in itself does not suggest that its origin was a hero cult. The bronzes are, in general, of the same types as in the nearby Heraion and also the terracottas and the pottery have counterparts in the published material from the Heraion.³⁶⁶ Presumably, this small Hera sanctuary was founded around 725 BC from the Argive Heraion for religious reasons which we cannot determine today.

The Post-Mycenaean finds in the Mycenaean chamber tombs in the neighbourhood of the Argive Heraion vary in character as stated by Blegen, and cannot all be considered Geometric/Early Archaic votive deposits. Some are definitely later and without actual votive character, while others only consist of scattered fragments, presumably having filtered into the tomb by chance.³⁶⁷ Genuine Geometric/Archaic votive deposits were apparently placed only in Tombs VIII, IX, XIX, XXVI, XXXIV, XXXVII, XL, and L,³⁶⁸ most of

which contained bronze finds. Tomb XIX had actually been broken into, while entrance in most of the others occurred after the roof had collapsed or the lintel broken. In Tomb XXXIV was found a goat's skeleton together with two human skulls, but as stated by Hägg, there were no certain indications of sacrifices, drinking ceremonies or meals.³⁶⁹ The deposits were placed either on the floor of the tomb or in the fill just above. Presumably most deposits were accumulated over a period of some time.³⁷⁰

Apart from one terracotta figurine in Tomb XIX and seven terracotta spoons from Tombs VIII - IX, the deposits comprised mostly pottery and bronze objects. In general, the offerings differ from those of known hero cults, but correspond with the finds at the Argive Heraion and the small Hera sanctuary and are of definite votive character.³⁷¹ However, Hägg concludes his study by observing that the pottery consists of "such objects that could equally well have been given as burial gifts, *kterismata*, in a contemporary burial."³⁷² Although the bronzes, in general, are of types known from the two Hera sanctuaries, there are differences. Pins are definitely in the minority and there are two objects which have no parallels in the two above-mentioned sanctuaries. One is a Laconian type pin, a so-called "Pilzkopf-Nadel" from Tomb IX and the other the so-called "Kalotten-Schale" from Tomb XL. According to Kilian-Dirlmeier, the former is not genuinely Laconian. Nor is it likely to be a local product, as its type is not recorded among the thousands of pins at the Argive Heraion. The bowl is definitely an Argos type, common in tombs of Argos throughout the Geometric Period, but not recorded from either of the two nearby Hera sanctuaries.³⁷³ The peculiarities of the vases as well as of some of the bronzes of the votive deposits in question, may indicate that the deposits in the Mycenaean tombs near the Argive Heraion were chiefly placed by male persons in contrast with the offerings at the two Hera sanctuaries.

The interest in the Mycenaean tombs

in the LG Period which was possibly shown mainly by the male inhabitants of Argos, does not alter the above conclusions concerning the relations between the Argive Heraion and Argos during the Geometric Period. The impression of a sanctuary independent of the neighbouring settlement given by the early monumental architecture of the Argive Heraion is strengthened by the study of the Geometric bronzes from the Argive Heraion.

The Greek bronzes at the Argive Heraion during the Geometric Period and the early 7th Cent. BC differ in so many respects from the bronzes in contemporary sanctuaries and tombs of the settlement of Argos, in regard to outside connections as well as local bronze manufacture, that they give the impression of two sites independent of each other. In spite of some connections, which increased throughout the Geometric Period, the differences in the bronze finds at the two sites are more striking than the similarities, taking into account the fact that they were only ca. 8 km. from each other.

If the Geometric sanctuary of the Argive Heraion was under direct control of the settlement of Argos during the Geometric Period, as is generally assumed, one should expect evidence of much closer relations regarding both the more humble local bronze products and the monumental prestige objects. In the former, one should expect indications for identical traditions and stylistic influences, whereas the fact is that the two sites give evidence of different ways of life as well as different connections to and influences from other Greek regions. In the latter group, the monumental bronze tripods are especially

significant. If the administrative body of the sanctuary were situated in Argos during the Middle and Late Geometric Periods, if the cult life at the sanctuary were organized from Argos, one should expect that such prestige objects as the monumental tripods also would be found in the settlement itself. Whether the bronze tripods were ordered for cultic use or dedicated by wealthy and influential persons, one should expect evidence of them in the settlement where they were ordered or manufactured. On the contrary, it seems that the itinerant artisans who manufactured the monumental Geometric bronze tripods set up at the Argive Heraion, passed Argos by, concentrating their efforts on this and other Greek sanctuaries in the eastern part of the Greek Mainland.

In my opinion, studies of the Greek Geometric bronzes from the Argive Heraion support my previous conclusions concerning the early monumental architecture from that site. During the period studied here, the available archaeological material indicates the Argive Heraion as independent of the contemporary settlement of Argos.³⁷⁴ In order to attempt to determine more precisely the period when the bronze artefacts of Argos and the Argive Heraion became inseparable, the Archaic Greek bronzes should be studied in the same way.³⁷⁵ However, the 8th - early 6th Cent. BC is the time of the emergent Greek city-states and many aspects of cultural, religious and economic character are of importance for defining the role played by the Argive Heraion, in particular, and the Greek sanctuaries, in general, in this crucial development.³⁷⁶

Notes

NOTE 1

IS I, in particular, Conclusions, 199 - 200.

NOTE 2

Cf. IS I, 173 - 175, notes 6 - 7 and 21.

NOTE 3

In all, 5.738 bronzes were found in C. Waldstein's excavations, many of which were discarded (cf. below notes 33 - 34) and 2.841 of which were catalogued (H. de Cou in AH II, 191 - 339). The finds from the later excavations are more limited in numbers, cf. in particular: Blegen 1939, 430 - 432 and 437 - 442 and Caskey - Amandry 1952, 176 - 183. All these bronzes are in the National Museum of Athens. I have handled most objects in the magazines and the most important ones in the showcases.

Catalogue numbers of the bronzes from Waldstein's excavations will be given as AH + no., those of other finds as AH II + category + no. The inventory nos. of the National Museums of Athens will be given as NM + no.

For possible Argive Heraion bronzes in other museums, cf. below note 10.

NOTE 4

Cf. esp. Foley 1988, chpt. IV, 80 - 101 with earlier references.

NOTE 5

A second paper will be divided into two main parts. I. Imported Bronzes and their Close Greek Imitations and II. Archaic Greek Bronzes. In a final paper I intend to look at more general aspects concerning the relations between Greek sanctuaries and settlements during the period in question. It will not always be possible to distinguish clearly between Geometric bronzes and early 7th Cent. bronzes. In some cases, especially where the 7th Cent. material forms a direct continuation of the Geometric bronzes, I shall carry the studies on directly. In others, especially where influences from the Near East can be observed, I postpone the examination until the forth-

coming paper, even though some of the bronzes may be dated before 700 B.C.

NOTE 6

Blegen 1939, 410 - 427 and Blegen 1937, 377 - 390. Cf. Hägg 1987 b, 98 - 99 and Foley 1988, 66.

NOTE 7

In the 8th - 7th Cent. BC votive deposits of the Mycenaean tombs in Argos, bronzes are rare, consisting of only a few pins, cf. Deshayes 1966, 231 - 232; Hägg 1974, 32; Foley 1988, 151 - 152 and Hägg 1992, 12. The relevant Argos sanctuaries, cf. Foley 1988, 139 - 142, IS I, 198 - 199 and Hägg, op. cit. 9 - 13.

Although there are a few PG and EG sherds and more finds from MG II onwards on the Larissa, cf. Courbin 1974, 565, note 2, the votive deposit with the bronzes is not dated earlier than LG, cf. Courbin 1955, 314.

I have been allowed to study the bronze finds from the Athena Sanctuary from both Courbin's and Vollgraf's excavations and shall refer to most objects in this article, as well as the bronzes from the Aphrodision in the Agora, from which I shall refer to some bronzes of types beginning in the Geometric Period.

I have not seen the material from three possible sanctuaries in Argos excavated by E. Deilaki, but still unpublished, Hägg, op. cit. 12 - 13, cf. pl. II, fig. 2, d - f.

NOTE 8

My definition of the Argolid is the Argive Plain, in accordance with Morgan - Whitelaw 1991, 80, fig. 1 and not the broader definition by Hägg 1992, fig. 1. Apart from Tiryns (Cf. Tiryns I, 107 and Jantzen 1975, 97 - 99), the bronze votives are not numerous in the sanctuaries of the Argolid during the periods in question, cf. Foley 1988, 153 - 154. However, as regards Tiryns in particular, Foley does not take into account the different conditions of preservation at the sanctuaries. At Tiryns there was not the same need to level with

large fills of votives as at the Argive Heraion, the main reason for the large quantities of bronzes preserved at that site. As regards e.g. the Kourtaki sanctuary, situated ca. 4 km. NE of Argos, only pottery and terracottas are mentioned among its thousands of votives, cf. ADelt 22, 1967, B, 178 sq., 23, 1968, B, 13 - 14 and ADelt 25. 1970, B, 155 - 156; Protonotariou-Deilaki 1984, 40; Foley 1988, 150 and 185, no. 60 (possibly a workshop), Morgan - Whitelaw 1991, 84 and note 24 and Hägg 1992, 13.

NOTE 9

Cf. note 3 above.

NOTE 10

Alleged Bronze Finds from the Argive Heraion.

Boston. Museum of Fine Arts

Comstock - Vermeule 1971, nos. 257 - 258 (Spirals), 279 - 282 (Rings), 284 (Ring) and 647 (Buckle). Inv. nos. 94.42 - 94.49.

Cambridge. The Fitzwilliam Museum

Inv. nos. Gr. 12. 1970 (Archaic Bronze Pin) and Gr. 13 - 14. 1970 (Bronze Rings.) Bought from Sale of Charles Waldstein's Collection. AR 1970 - 71, 69 - 70, no. 2 q and fig. 2 (The pin).

Hannover. Kestner Museum

Inv. no. 1928. 264. Geometric horse. Bought from Charles Selman and said to have been found in 1927 near the Argive Heraion. Zimmermann, 27 and 47, no. ARG. 123, pls. 9 and 73.

I do not find this horse stylistically related to the certain Argive Geometric horses (cf. pp. 54-57), but rather with a group of Corinthianizing horses which have the same beak-like muzzle, sharp-edged mane, high rump and flat legs with pronounced details as well as the same thin, solid base. The production of this group is localized to Central Greece, the most secure provenance being that of Anavra, cf. Zimmermann, 218 - 229, Locride, esp. nos. LOC. 15, 18 - 19, 20 and 23.

The Hannover horse differs from the Ar-

give Heraion types also in the relief decoration of the underside of the base, cf. pp. 54-56 and notes 104, 148 and 151 below.

Oxford. Ashmolean Museum

The fibula, Inv. no. 1893. 262, for which Blinkenberg, 80, III, 3 b, gave the Argive Heraion as a possible, but doubtful provenance, is one of several objects given to the museum by J.L. Myres (Inv. nos. 1893. 261 - 272). Its provenance is not certain, although possibly Mycenaean.

Inv. nos. 1894. 120 and 121, Geometric horses.

In the Accessions Register the provenance is given as "from Argos." In red is added "Heraeum".

1894. 120 = Zimmermann., 131 and 154 - 155, no. LAC 117, pls. 33 and 77. Unlike Argive statuettes (cf. pp. 54-56) its base plate is perforated and has a projection. I am inclined to agree with Zimmermann that it is Laconian. It may, however, belong to an Arcadian school with strong Laconian influences, as it stylistically is very close to LAC 118 from Bassai which is considered Arcadian by Voyatzis, 1990, 138. 1894. 121 = Zimmermann, 134 and 164, nos. LAC 159, pls. 37 and 78. Laconian as classified by Zimmermann; stylistically it is closely related to the group of horses, Zimmermann LAC 157 -163, the last of which was found in Sparta (Zimmermann. LAC 163).

The results of Craddock's technical analyses to which Zimmermann refers under nos. LAC 117 and 159 differ for the two horses, 1894. 120 and 121. Cf. Craddock 1976, esp. 103 -108. Inv. no. 1894. 120 = no. 421, p. 108, has 90.0% Cu and 9.3 % SN and Inv. no. 1894. 121 = no. 1170, p. 107, has 97.0 % Cu and 2.0 % SN.

NOTE 11

Cf. AH I, 65 and 67 (Gordon); Rangabé 1855, 9 (Kallergis) and 20 and 23; Bursian 1854, XVI; and AH I, 67- 69 (Rangabé and Bursian).

The museums authorities in Argos, Athens and Nauplion do not appear to have any information about these early finds.

NOTE 12

Mycenaean Bronzes

Cf. AH II, 193, cf. AH 2263 (sickle), AH 2265 -67 (NM 14029) chisels, AH 2730 - 2732 (NM 20471) (nails), AH II, 299 - 300 and 325, pls. CXXVII and CXXXIII.

Classical or Later Bronzes

AH 1829-30 (NM 20696/2 - 3)(cut - out ornaments), AH II, 274 and pl. CV; AH 2262 (NM 13978)(Roman key), AH II, 299 and pl. CXXVI; AH 2748 - 50 (NM

20805/5 - 6 and 20806) (ornamental door nails, 4th Cent. B.C. - Hellenistic, AH II, p. 326 and pl. CXXXIII sq., cf. JdI 1911, 204, fig. 16 (Langaza Tumulus); and M 49.99, Hesperia 1952 , 182, no. 113, pl. 46 (decorative attachment plate to door. 4th Cent. BC - Hellenistic). Found in loose earth immediately above the archaeological deposit. Besides the reference loc. cit. to Olynthos, cf. also Ol. IV, no. 940, pl. LIII and p. 149 with ref. to Ol. Inv. nos. 5612 and 12041; JdI 1911, 199, fig. 8 (Langaza Tumulus); Carapanos 1878, pl. XLVII, No. 10 (= NM Carapanos Collection, no. 335) and the Heroon. Kalydon. Poulsen - Rhomaïos 1927, pl. LXXXVI and Dyggve - Poulsen - Rhomaïos 1934, 337 and Fig. 44. However, the attachment plate of the Kalydon door , in the Museum of Agrinion, has four lotus buds and that of the Dodone Bouleuterion in the Museum of Joannina has a different type of palmette. The arm rings with hollow hemispherical beads, AH 973 - 974 (NM 20916), AH II, 251, pl. LXXXIX, are presumably Roman or later, cf. Philipp 1981, 259, Nos. 981 - 983, pl. 59.

NOTE 13

For the find spots, in general, cf. AH II, 191 - 192, Blegen 1939, 427 - 428, 430 - 432 and 437 and Caskey-Amandry 1952, 168 - 169.

Brownson 1893, 210, mentions early bronzes found as far west as the Gymnasium, including a Geometric horse and a long pin ("spit").

NOTE 14

Cf. IS I, 191 - 193 and notes 131 - 135, cf. notes 137 -139 and cf. note 136 below.

NOTE 15

Cf. IS I, 192 and note 136.

NOTE 16

Cf. IS I, 176, note 33.

NOTE 17

Northeast Stoa and Area E of Stoa

AH 14 (NM 13965 and 13994) and AH 17 (NM 13984 and 13946), (two Geometric horses with separate bases), cf. pp. 56-58 and notes 155 and 169 below; AH 37 (NM 13959) and AH 39 (NM 13960) (two bird pendants), cf. pp. 63 and 65, Fig. 29 and notes 208 and 199 below; AH 2074 (NM 20602 α) and AH 2172 (NM 20618 β) (two vase handles), AH 2254 (NM 14025) (a fragmentary wheel) as well as five pins, five fibulae and a seal ring, AH 966 (NM 20919).

NOTE 18

Foundations of Classical Temple

Cf. Brownson 1893, 221:"... pins and clasps of bronze, a bronze cock (presumably identical with AH 47 or 48, cf. IS I, 201), several scarabs, one of them threaded so to speak, on a bronze pin..."

The find contexts of the 1892 excavations were not given in the final publication, cf. IS I, 174 and note 7.

NOTE 19

Cf. IS I, 174, 184 - 186 and 195 - 196.

NOTE 20

Cf. IS I, App. 201 - 202.

NOTE 21

West Building

AH II, 191 - 192.

Although the excavations of the West Building began in 1892, cf. Brownson 1893, 223 - 224, the bronze objects labelled West Building, about 150 in number, were all found in later seasons, due to the lack of registration of bronzes in the first season. Cf. IS I, 174. Of particular interest are the following objects: AH 19 (NM 13951) (Geometric deer), note 138 below; AH 23 (NM 13972) (bull's head attachment), cf. note 170 below; AH 30 (NM 13951) (mouse on human hand on top of iron bar), AH 36 (NM 13958) (bird pendant), cf. p. 65 below, Fig. 29 and note 208; AH 51 (NM 20468) (feather), AH 1749 (NM 20676 β) (fragment of cast support for hammered tripod (cf. p. 49 and Fig. 16 and note 96 below) and scraps and spills, cf. notes 33 - 34 below.

NOTE 22

Eastern Retaining Wall

Caskey - Amandry 1952, 176 - 183, bronzes; 210 - 212, summary and absolute chronology. The deposit contained many lotus phialai and fragments of other bronze vases as well as a fragmentary Archaic bronze statuette, NM 16357.

NOTE 23

Back of South Stoa

The bronzes - about 200 in number - are mainly of the same types as from the fills above, also containing several lotus phialai and other fragments of bronze vases. Of particular interest are the following objects: AH 8 (NM 13985) (Geometric horse), cf. note 138 below; AH 33 (NM 14000) (handle ending in a serpent's head), AH 970 (NM 20917) (seal ring), AH 1783 and 1786 (NM 20685/1 and 4) (Geometric sheet with tremolo decoration), cf. p. 84

and note 325 below; AH 2784 (NM 20817) (fragment of Geometric tripod), cf. p. 46 and Figs. 12 - 13 and note 83 below. Cf. also bronze scraps, note 34 below.

NOTE 24

Southern Slope

The bronzes - also about 200 in number - are of the same types as those mentioned above, but include some of the best Archaic figures: AH 3 (NM 13974) (rider), AH 5 (NM 13975) (mirror support), AH 25 (NM 13973) (bull's head attachment) and AH 27 (NM 13950) (bull, cf. note 170 below); AH 28 (foot of ox or cow); AH 1556 (NM 20672 y) (bell pendant) and AH 2019 (NM20590) (pyxys pendant), cf. pp. 67-68 and note 224 below. The bronzes from Blegen's excavations, Blegen 1939, 437 - 442, figs. 23 - 29 comprise also the Egyptian statuette (NM 16554) and a lid with seated birds (NM 16562), cf. p. 63 and Fig. 27 and note 202 below.

NOTE 25

Cf. Lauter 1973, figs. 3 - 4.

NOTE 26

Northwest Building

AH 12 (NM 13947) (Geometric horse), cf. pp. 54-57 and note 148 below and Fig. 17, and AH 16 (NM 13964) (Geometric lion?), cf. p. 56 and note 157 below and Fig. 21; AH 22 (NM 13466) (Geometric small animal), cf. p. 57 and note 164 below; AH 24 (NM 13942) (Archaic bull), cf. note 170 below, and AH 965 (seal ring). Also a fragmentary support with a lion's paw, AH 2230, AH II, 296, pl. CXXV.

NOTE 27

North Stoa

It is not listed as provenance in the Bronze Catalogue of AH II, nor does Brownson 1893, 221 - 222, mention any bronze finds here.

NOTE 28

Cf. Lauter 1973, fig. 4 and IS I, 177.

NOTE 29

Kilian 1983, 145 and notes 37 - 41, refers to the following sanctuaries with evidence of bronze workshops: Asea, Delphi. Isthmia, Kalapodi and Olympia. For Kalapodi, cf. also note 127 below; for Isthmia, cf. Rostoker - Gebhard 1980 (Classical) and for Delphi op. cit. p. 361. For Olympia, cf. Zimmer 1990, 21 - 24 (Geometric), 39 - 50 (Archaic) and 57 - 60 (Classical) with earlier references. Especially important for the present study are the fragments of clay

matrices for parts of Geometric tripods, as Inv. T 859, Maass, 26 and pl. 27 and Beil. 11, for a Matrice Tripod leg and Born - Moustaka 1982, esp. pls. 3 - 5, a male statuette in form of a handle support for a hammered tripod, cf. Zimmer 1990, fig. 2 and pl. I, respectively.

To Kilian's list can be added: Akovitika in Messenia (Geometric), cf. Zimmer 1990, 21; the Acropolis of Athens (NM 6984), funnel and runners from casting of statue, on exhibition in Athens NM, Room 37, the South Slope of the Acropolis, Zimmer 1990, 62 - 71, and the Hephaisteion, Zimmer 1990, 60 - 62; Nemea, Miller 1977, 19 - 20; Birge - Kraynak - Miller 1992, 149 and 177 and Zimmer 1990, 50 - 57 (Classical); the Heraion of Samos, Heilmeyer 1981, 442 and 452 and Zimmer 1990, 30 - 32 (Late Geometric/ Archaic); Tegea, AJA 1994, 313 (Late Geometric to Classical) and Thasos, Artemision, Rolley 1984, 226, fig. 201.

A mould for a pendant in Perachora, Perachora I, 177 and pl. 79, 12, cf. Perachora II, 528, may suggest bronze work at the site or gold and silver work like the AH mould, note 31 below.

The subject has recently been restudied by Risberg 1993, who adds Aigina, Bassai, Delos and Aetos on Ithaca.

NOTE 30

Faulty bronzes at AH: AH 2218 (NM 14008) and AH 2221 (NM 14007) (Geometric tripod legs), cf. pp. 43-45 and notes 69 and 78 below and Figs. 6 - 8, AH 2837 (NM 20832/2) bird pendant, cf. p. 63 and note 201 below.

Bronze repairs: AH 47 (NM 13952) bird pendant, cf. p. 65 and note 210 below and Fig. 30; AH 87 (NM 20472), AH II, 208 and pl. LXXVIII, AH 2585, AH II, 314, pl. CXXXI and AH 2602, AH II, 317 (pins, cf. K.-D. Nadeln, nos. 880, 1088 and 1029); AH 877 (plate fibula, cf. note 251 below); AH 881 (NM 14033) (plate fibula, cf. p. 62 and note 197 below and Fig. 25); AH 1750 (NM 20676) (repair piece from cast tripod? cf. Maass, 131 and pl. 56, Br. 8675).

NOTE 31

Terracotta mould: (NM 14218), AH II, Tc 277, p. 43, fig. 84 and p. 498. The mould is broken; seven of its cavities for ornaments are preserved.

Also for AH 2832 (NM 20831/3) the identification with a mould is suggested, AH II, 331. The bronze plate, the back side of which is left unfinished, has remains of four cavities of different sizes.

NOTE 32

Ingots

AH 2834 and 2835 (NM 20830/4 and 5), cf. AH II, 331 and pl. CXXXVI. The second ingot is best preserved. Diam. 25.3 cm. H. 5.3 cm. Its top is curved, the underside flat. Green patina. The patina of AH 2834 is black. (Cf. Heilmeyer, 1969, 6 - 7 and Fig. 10 and Heilmeyer 1981, 442 - 443, figs. 2 - 3 and Brize 1991, 322 - 323, fig. 2 (Heraion of Samos) and Athens NM 20251. In exhibition Room 37.

NOTE 33

Spills

AH 2840 - 2841 (NM 20831/4 - 5). AH II, 331, pl. CXXXVI.

Loc. cit. are mentioned six similar, but discarded pieces, one of which was found in the West Building. For similar spills, cf. Hesperia 1980, 351, pl. 104 b.

NOTE 34

Bronze scraps

AH 1845 (NM 20699 β) AH II, 274 and pl. CVIII (folded bronze sheet with attached foot) (cf. Hesperia 1980, 351 and pl. 105 a - b); AH 2250 (NM 20632), AH II, 297 - 298 and pl. CXXVI and AH 2839 (NM 20831/6), AH II, 331 and pl. CXXXVI (fragmentary objects showing chisel cuts, the last-mentioned one apparently unfinished); and possibly AH 2038, AH II, 287 and pl. CXVIII, fragments of lead and bronze which have been bent and show traces of having been melted. Cf. AH II, 331: "... a number of pieces, partly castings, partly pieces of sheet bronze, which have been partly melted and fused together, or mixed with substances as lead, rock, sand. Most of them show traces of fire. Uncleaned, seventy-eight, of which two from back of South Building near retaining wall".

The many other mentions of discarded bronzes, among which are small fragments of sheet bronze, cannot be regarded as scraps collected for remelting without further information, cf. e.g. AH II, 274. However, these find spots are all in the West Building or the Back of South Building.

NOTE 35

Cf. notes 33 - 34 above, West Building and Back of South Building. These two find spots have, however, mostly secondary finds, cf. pp. 38-39 above.

NOTE 36

AH 2830 -2831 (NM 20830/1 - 2), AH II, 331 and pl. CXXXVI; the former is pre-

sumably part of a vase with an Archaic tongue pattern, the latter may be part of a bronze funnel, cf. *Hesperia* 1980, 355, pl. 106 d; AH 2043 may possibly also be part of a funnel, cf. AH II, 288 and pl. CXIX.

NOTE 37

AH 2829 (NM 14004), AH II, 330 pl. CXXXVI. Casting waste. The funnel measures 8.7 cm. in Diam. and 3.8 cm. in visible height, the pouring cup 3.9 cm. in Diam. and 4 - 4.5 cm. in visible height, the Diam. of the "bowl-like" part varies between 8.9 and 9.1 cm. and ca. 3.5 cm. in height. One of the small, raised, curved parts measures 2.4 x 1.8 cm. and 0.9 cm. in height, the other 1.2 cm. in Diam. and 0.4 cm. in height. The schematic rendering of details of the lion's paw, with raised lines, reminds one of that of early 6th Cent. lions, as e.g. the Loutraki lions in the Ny Carlsberg Glyptotek, Inv. nos. 1296 - 1297, Poulsen 1951, Cat. nos. 5 - 6, illustrations, e.g. Gabelmann 1965, No. 58, pl. 8, and Johansen 1994, 36 - 39, Cat. nos. 2 - 3.

NOTE 38

Cf. e.g. Coldstream 1977, 149 - 150, Aupert 1984, 25 and Foley 1988, 96.

NOTE 39

Cf. pp. 84-85 below and cf. Daux 1959, 768 and fig. 24; Courbin 1963, 71 - 73, 79, 98 - 100 and fig. 8; Desborough 1972, 162 and pl. 31 A and Hägg 1982, 305, no. 14 (Submycenaean/Early Protogeometric oven for extracting silver from lead ore).

NOTE 40

Herrmann 1964, 24 - 28, cf. pp. 52-53.

NOTE 41

Technical criteria should, in my opinion, be used with some caution, taking into account also the evidence for itinerant artisans, cf. p. 52 below. Craddock's analytical results show variations in the metal compositions of, for example, Geometric horses of presumably the same site and the same origin, cf. note 10 above (Oxford), and in some cases even the metal analyses of joining fragments may show variations, cf. e.g. AH 2223 - 2224, Rolley et al. 1986, 127 and 134, cf. note 82 below. However, metal analyses have proved that some differences may be chronological. For example, the percentage of tin in Near Eastern and Greek bronzes differs until about 750 B.C. and there are also differences related to the spe-

cific types of objects, cf. Rolley et al. 1983, 127 and Antonaccio Sanpaolo 1990, esp. 104 - 106 and 118 - 123 for the relevant periods.

As regards the patina of the Argive Heraion bronzes, one should remember that the bronzes from Waldstein's excavations were treated in a bath of zinc, hydrochloride and water; from this treatment they acquired an artificial reddish-brown colour, cf. AH II, 192, note 2.

NOTE 42

Iron was more common at the Argive Heraion than stated by Foley 1988, 96. Apart from the iron obeloi and iron bar mentioned by her (cf. IS III, 41 and 45), there are several bronzes catalogued, parts of which are made of iron, e.g. bronze figures on iron bars, AH 29 (NM 13968) and AH 30 (cf. note 21 above) or pins of iron with an original bronze head, cf. AH II, Index, Pins, as well as iron used for many other objects, e.g. AH 871, AH 2231 - 2234, and AH 2712. For finds of molten iron on the Old Temple Terrace, cf. Brownson 1893, 213 and IS I, App., for quantities of iron rings in the western fill, cf. Brownson, op. cit., 224 and for iron implements in the Gymnasium, op. cit., 210 - 211.

Waldstein mentions iron finds several times, e.g. AH I, 61, 77 and 79. For iron finds from the earlier excavations, cf. Rangabé 1855, 9 (Kallergis) and 23 (Rangabé - Bursian) and from later ones, Prosymna, 18; Blegen 1939, 442 and fig. 26 and Caskey - Amandry 1952, 183 and pl. 47 A - K. Also the sanctuaries in Argos seem to have used more iron than assumed by Foley loc. cit.; Courbin found several iron implements in the Athena sanctuary on the Larissa, cf. note 328 below and there are also iron fragments in the Aphrodision material.

NOTE 43

Geometric iron tripods are best known from Olympia, apparently chiefly found underneath the Hera Temple and in its immediate neighbourhood (cf. Furtwängler 1890, 75 - 76 and Maass, 126 - 130 and 225 - 227 [Catalogue]). However, there are separate finds in other sanctuaries, e.g. Delos (Delos XVIII, 65, notes 13 - 15), Dodone (Carapanos 1878, 108, no. 2, pl. XLVIII, 6 and Maass, 129, note 4), Isthmia (Isthmia IV, 1987, 27 and pl. 80 d) and possibly also Perachora (cf. Perachora I, 75). Apparently the iron tripods follow the development of the bronze tripods, cf. Maass 127 - 128 and Matthäus 1980, 121. For iron votives in Greek sanctuaries in general, cf. Kilian 1983, esp. notes 5 - 12.

NOTE 44

The basic studies of the Greek Geometric tripods are Furtwängler 1890 and Benton 1938 a and b.

Of the more recent studies, I have especially used the following: Karouzos 1952; Willemssen (cf. reviews, *AJA* 1959, 94 - 95 (S. Benton) and *Gnomon* 1960, 459 - 463 (P. Amandry); Gehrig 1964; Schweitzer 1969, 176 - 198; Weber 1971; Touloupa 1972; Rolley 1973; Weber 1974; Coldstream 1977, 334 - 339; Maass 1977; Rolley 1977; Maass (cf. review, Rolley C. 1983, 329 - 330); Maass 1981; Bol 1985 b, 30 - 38; Floren 1987, 31 - 51; Foley 1988, 88 - 89 and 92; Rolley 1992, 39 - 43. Cf. also notes 10 and 41 above, references to metal analyses by Craddock, Rolley et al. and Antonaccio Sanpaolo.

NOTE 45

Cf. note 21 above and note 96 below (AH 1749. West Building) and note 23 above and note 83 below (AH 2784. Back of South Stoa) and IS I, 176 - 177, note 33, and note 65 below (NM 16551. Altar site) and IS I, 192 - 193, note 139 (NM 16555. NE of Old Temple Terrace).

NOTE 46

The question of the Protogeometric bronze tripod production, to which I refer the Lefkandi moulds (cf. Popham - Sackett 1979, 95 - 96 and pls. 12 - 13 a and Zimmer 1990, 19 - 20), is still under debate, cf. note 108 below, but I shall not discuss it as it has no relevance for the finds from the Argive Heraion. The earliest geometric bronze tripods with legs of polygonal section found at Olympia are not represented at the Argive Heraion.

NOTE 47

Furtwängler 1890 classified the Olympia bronze tripods into three main groups which in later studies of Olympia tripods were changed to four groups (Willemssen and Maass). Schweitzer and Coldstream classified five groups by dividing the Solid Cast Tripods into two. Cf. Rolley 1977, 15 - 23, for a thorough and clear outline of the studies of the Geometric tripods until 1977.

NOTE 48

The development of height and proportions of Geometric tripods was studied by Willemssen and Maass. For the early tripods, cf. especially the complete Olympia tripod B 1240, Willemssen, 17 and pls. 1 - 2, and Maass, 6 - 7, pl. 1 below and for the

later tripods, the hammered examples, Maass, 76 -77.

NOTE 49

Cf. p. 48 and notes 91-,92 (AH 2219) and p. 48 and note 95 (AH 1748) below.

NOTE 50

For miniature tripods in Olympia, cf. Maass, 117 - 125 and 212 - 225 (Catalogue) and pls. 54 - 62, and in other sanctuaries, cf. Sakellarakis 1988, 174 - 177, notes 19 - 33 and figs. 1 - 3.

NOTE 51

Maass, 7 - 9.

NOTE 52

Willemsen, 28 - 53. Willemsen's classification is essentially accepted by Maass, 3, whereas Rolley 1977, 60, does not agree.

NOTE 53

Willemsen, 28 - 38, figs. 6 - 7, pls. 1 - 2 left, 6 above, 7 - 10, 23 above and 28 - 34 and Maass, nos. 1 - 4 and 50 - 63, Beil. 1 and 3 and pls. 1 - 5 and 19 - 23. Also one of the so-called "Kranzhenkeln" seems to belong with this group, because of its handle section as well as its decoration, Br. 7872, cf. Willemsen, 38 - 39, fig. 8 and pls. 34 and 40. Both Willemsen, 37, and Maass, 15, regard the handles decorated with relief lines as late, cf. Willemsen, pl. 30 right and Maass, no. 62, pl. 22. These handles seem to form a natural transition to the rib handles of Relief Tripods.

NOTE 54

Cf. Willemsen, pls. 7, 9, 23, 26 and 30 - 31 and Maass, no. 1, pls. 2 and 4 and nos. 55 and 62, pls. 21 - 22.

NOTE 55

For the figures placed on the handle straps, cf. Willemsen, pls. 31 - 32. Inside one of the Ithaca handles there may have been a bull, Benton 1929 a, nos. 6 and 18, but the Ithaca tripods are not reliable in details due to their many repairs, cf. note 119 below. For the decoration on top of the handles, cf. Willemsen, 56 - 61, pls. 8, 29 - 30, 34, 40 and 41 and Maass, nos. 59 - 60, pl. 19 and p. 16 sqq. where he also observes the connection to the decoration of Cypriot rod tripods and dates the birds later than the bull's heads.

NOTE 56

For cauldrons with both legs and handles attached, cf. B 1240, Willemsen, 1, pl. 2

and Maass, pl. 1 below and Maass, no. 2, pl. 3. The legs are decorated with twisted vertical relief lines, forming a rope pattern.

For tripod legs with applied spiral decoration, cf. Willemsen, pl. 14 (B 1241) and pls. 19 - 20 (B 1250) and Maass, nos. 36 - 37, pl. 16 = Willemsen, pls. 13 and 20.

NOTE 57

Olympia. Solid Cast Tripods. Subgroup I

For the handles and handle straps of Subgroup I, cf. notes 53 - 55 above.

Judging from the decoration of legs attached to cauldrons with such handles (cf. note 56) I regard the following legs as belonging to Subgroup I, Maass, nos. 7 - 16, 18 - 25, 27 - 28, 35 - 38, 45 and 47, Beil. 1 - 2 and pls. 7 - 17 and 67 right and Willemsen, pls. 3 - 5, pl. 6 below right, pls. 11 and 12 above, pl. 13 below, pl. 14 above and right, pl. 15 right, pl. 16 above left, pl. 17 left, pls. 19 - 20. (Among which are Maass, nos. 35 - 38).

For some leg fragments a definite classification does not seem possible and the open work handles may belong elsewhere, cf. notes 63 - 64 below.

NOTE 58

Willemsen, 39 - 44, figs. 8 - 9 (upper row), and pls. 23 below, pls. 35 - 39 (except for pl. 37 below right, pl. 38 right and pl. 39 left), pl. 40 (the three central fragments and above right) and Maass, nos. 5 - 6 and 64 - 66, Beil. 1 and 3, pls. 6 and 24 - 25.

For exceptions to Willemsen's "Kranzhenkeln", see notes 53 and 60; from Willemsen's "Treppenhenkeln" are generally excluded the handles which Maass, 19, identified with the step handles of the Fan Grooved Tripods.

Like the latest handles of Subgroup I, cf. note 53 above, these handles could easily develop into the rib handles of the following group.

NOTE 59

Maass, no. 64, pl. 24.

NOTE 60

Cf. Willemsen, 53 - 61. The handles of "Kranzhenkeln" type with birds, Willemsen, 59 - 60, do not belong with this subgroup. For Br. 7872, cf. note 53 above. The Idaean cave example is Cretan, cf. Maass, M. 1971, 58, no. 37, pls. 24 - 25, whereas Br. 2582, Ol. IV, no. 638, pl. 29 is an open work handle which seems close to the Saloniki handles, cf. note 62 below.

Willemsen, 59, also suggests that a bull served as a handle figure, B 12, pl. 42; but the statuette was not found in context and bulls or bulls' heads are not usually connected with this type of handles.

NOTE 61

Br. 5897. Willemsen, pl. 23 below ("Doppelkranzhenkel") and Maass, no. 5, pl. 6 and Beil. 1 = Willemsen, pl. 2 below right and pl. 39 right ("Schnurrhenkel"). Maass, 18, regards Br 5897 (which he calls a "Trep-penhenkel") as early, Maass, no. 5 as late.

NOTE 62

Olympia. Solid Cast Tripods. Subgroup II

For the handles, cf. note 58; for legs attached to cauldrons with handles, cf. note 61 above.

I regard the following legs as probably belonging to Subgroup II: Maass nos. 17, 26, 29 - 34, 46 and 48 - 49, Beil. 1 - 2, pls. 10, 12 - 14, 16 and 18, cf. Willemsen pl. 2 right below (= Maass no. 5), pl. 12 below and right, pl. 13 above, pls. 15 left (= Maass no. 30), pls. 16 right and 17 right, pl. 18 above (= Maass, No. 46), pls. 21 right, 22 above and 23 below (= Br.5897, cf. note 61).

Some of the legs cannot be definitely placed in either of the two main subgroups.

NOTE 63

Cf. Maass, 9 - 10 for the legs, nos. 36 - 38 of Subgroup I, which are regarded as closely connected chronologically to the Application Tripods of the Relief Group and cf. Maass, 20, for handles transitional between the two groups. Cf. Maass 19 - 20 for the transition from Subgroup II to Relief Tripods, esp. Maass, no. 5.

NOTE 64

Open work handles are especially difficult to place. The handles with radiating triangles presumably do not belong to these groups, cf. Maass, 16; and cf. Maass, 20, where he sees some of the open work handles as forming a transition to the Relief Tripods.

As to tripod collections from other sanctuaries, the Delphi tripods especially are difficult to classify according to the above criteria, cf. e.g. Rolley 1977, 62, no. 442, pls. VII and XLI and cf. notes 119 and 121 below. To a certain degree this applies also to subgroups of the Relief Tripods, cf. notes 120 and 122 below.

Nor can I place with certainty the terracotta mould fragments from Akovitikia, Zimmer 1990, 21, cf. Themelis 1969, Fig. 5. The tripod collections from Ithaca and Sa-

mos present special problems. For Ithaca cf. below notes 119 and 120. Not one of the Samos fragments seems to conform fully with the Olympia series. In most cases, they are so specific that they presumably should be regarded as local. Cf. Gehrig 1964, 98 -101, nos. 55 - 58. Nos. 56 and 58 are open work handles in thin bronze plate, see AM 1968, p. 286 and 295, nos. 106 and 132, pls. 116 and 128; a third one of the same type, B 2184, is on exhibition in the Samos Museum. Gehrig no. 55 is apparently a normal Relief Tripod rib handle, but the specific feature noted by Gehrig, a greater distance between the inner rim and the first rib than between the others, seems to be unique in bronze tripods; it is repeated in a local terracotta handle (Willemsen, pl. 61). Gehrig no. 57, p. 100, and Maass, 4, note 24 (= AM 1972, p. 138 and pl. 54) are Archaic miniature tripods. Maass 1977, 44, note 37, refers to a tripod leg of hammered bronze plate in a lead covering, possibly with an original wooden core, B 579.

NOTE 65
NM 16551

Blegen 1939, 430 - 432, fig. 17. All measurements are given here. For the provenance at the Altar site, cf. also Prosymna, p. 17 and IS I, p. 176, note 33. Willemsen, 61 and pl. 43; Herrmann 1964, 44 - 45, figs. 28 -29; Herrmann 1966, 98; Kunze 1967, 215 and 223 - 224; Schweitzer 1969, 135, 139, 154 and pl. 25; Rolley 1969, 23, note 6 and p. 30. Weber 1971, p. 18 and note 41 (who, however, regards the figure as decoration of a hammered tripod handle); Maass, 44 - 45. Hiller 1979, p. 24 note 16, (who considers it LG on stylistic criteria); Paleologou 1980, 77 - 78; Schmaltz 1980 p. 31 (who apparently also regards the figure as decoration of a hammered tripod handle); Langdon 1984, 326, no. 33; Floren 1987, 46 -47, pl. 4,1. Foley 1988, 93 - 94, pl. 18 b; Bosshard 1990, 16; Croissant 1992, 75, pl. 24, fig. 11.

NOTE 66

Willemsen, 61, ref. to Br 7157, cf. pp. 42 and 60 - 61, pl. 40 and fig. 8. Maass, 18 and 22, places the whole Olympia tripod with a "Schnurrhenkel", no. 5, among the late Solid Cast Tripods, cf. also note 61 above.

NOTE 67

AH 2220 (NM 20629 B)
AH II, 295, pl. CXXXIII.
Rolley 1992, 42.

NOTE 68

Cf. Br. 5897, Willemsen, pl. 23 below ("Doppelkranzhenkel") and Maass, no. 5, pl. 6 and Beil. 1. ("Schnurrhenkel"). Cf. note 61 above.

NOTE 69

AH 2218 (NM 14008)

AH II, 294 and pl. CXXIV. The section here must come from the very bottom of the leg as it does not show the hollow of the back.
The extra coating of bronze forms a slanting line, starting at the left-hand corner of the front about 3.2 cm. above the bottom and reaching only 0.4 cm. above the bottom at the back corner of the left side, 0.2 cm. at the back corner of the right side. Rolley 1992, 42 - 43.

NOTE 70

Maass, 21, gives a definition of Relief Tripods based on the form of their legs: "... wo sich im Querschnitt ... eine Ausrichtung auf die geschmückte Vorderseite bemerkbar macht". The trapezoidal form of the section of AH 2218 shows that the transition to Relief Tripods is imminent, but not accomplished. For corresponding sections, cf. esp. Willemsen, 17, Ohne No. pl. 21 right, fig. 4, Reihe 5 and Br. 1251, p. 24, pl. 24 right and fig. 5.

NOTE 71

Willemsen, 62 - 99 and Maass, 21 - 47. For the distinction between the legs of early Relief Tripods and Solid Cast Tripods, cf. note 70 above.

NOTE 72

Maass, 21 and 24 - 27. Rolley 1983 b, 331, disagrees with his observations which I basically follow.

NOTE 73

Maass, 28 - 32 and 150 - 156, nos. 69 - 104, Beil. 4 -7 and pls. 26 - 28. For nos. 105 - 107, cf. p. 46 and note 87 below.

NOTE 74

Olympia. Application Technique Tripods

For the legs, cf. note 73 above.
As the ornamentation of the legs is the criterion for the classification of Relief Tripods, the grouping of the handles is less certain. One starting point for the identification of handles of these tripods is the spiral ornamentation of some open work handles, cf. Maass, 42 - 43.
The handles are the two first phases of Maass' Relief Tripod handles, Maass, 40 -

43, nos. 124 - 144 ((Except no. 137, open work handle with radiating triangles) and possibly nos. 145 -146 and 150), Beil 12 - 14 (with drawings of handle figures) and pls. 35 - 39. No. 132 has decoration of birds and no. 140 of a lion. Some of the Relief Tripod handles cannot be placed in either group with certainty.
For Delphi, cf. below notes 120 and 122.

NOTE 75

Maass, 34 - 39 and 156 - 162, nos. 105 - 123, Beil. 7 - 11 and pls. 29 - 34.

For Nos. 105 - 107, cf. p. 46 and note 87 below.

No. 121 is unique, as the rows of stylized birds enlarging the legs, are not found in other Matrice Tripods; apparently the piece is a repair, cf. Maass, 162.

For the tripod with a limited use of semi-circles. Maass, no. 115, cf. note 86 below.

NOTE 76

Maass, nos. 111, 115, 164 and 165, Beil. 9 - 10 and 16 - 17 and pls. 31 and 38.

Cf. also note 122 below, Kalapodi.

NOTE 77

Olympia. Matrice Technique Tripods
Maass' later phases of Relief Tripod handles, Maass, 44 - 46.

For legs and connected handle straps, cf. notes 75 and 76 above.

Unconnected handle straps, Maass nos. 120 and 166 - 169, pls. 34 and 42.

For handles and handle figures, Maass, nos. 111, 115, possibly 145 and 149, 151 - 154, 157 (Kassel), possibly 158 -160, 161, 163 - 173, Beil. 9 - 10 and 15 - 17 (with drawings of handle figures) and pls. 40 - 42.

NOTE 78

AH 2221 (NM 14007)

AH II, 295, pl. CXXIV.

Willemsen, 69 - 70, fig. 12.

Schweitzer 1969, 187, fig. 103.

Maass, 25, note 30, cf. p. 36, note 67.

Rolley et. al. 1986, 127 and 134, no. 106 (Cu 92.5 % (÷Sn), Pb 1.00%.Fe 2.15%).

Foley 1988, 99, note 93.

Zimmermann, 45, note 190.

Rolley 1992, 42, connects it with other Matrice Tripods with a wheel-formed ornament ("a roue") in the metope, ascribing the whole group to Corinth.

NOTE 79

AH 2221 and Rolley 1977, 54, no. 391, pls. VI and XXVI = Inv. No.2441. Cf. Maass, 25 and note 30.

NOTE 80

Cf. Maass, 25, notes 28 - 30.

Several Olympia tripods use the same matrices, in one case comprising a tripod in mixed technique, Maass nos. 106 and 108, and Maass also gives several examples from Olympia and Delphi of the use of the same matrices for two or more tripods, cf. in particular:

Isthmia 2826 used the same matrix as Olympia, Maass no. 110 and possibly also Delphi, Inv. No. 8956.

The tripod leg from Kalapodi, B 643, used the same matrix as Maass no. 109, cf.

Felsch 1980, 62 and fig.35.

NOTE 81

AH 2222 (NM 20629 γ). AH II, 295, pl. CXXIII.

Gehrig 1964, 99, note 48.

Rolley et. al. 1986, 127 and 134, no. 109 (Cu 86.08 %, Sn 1.17 %, Pb 1.55 % and Fe 4.37 %).

Rolley 1992, 42.

NOTE 82

AH 2223 - 2224 (NM 13992), AH II, 295, pl. CXXIV.

Willemsen, 98, here compared with Maass, no. 173.

Maass, 23 and note 16, here compared with nos. 154 and 165.

Rolley et. al. 1986, 127 and 134, nos. 107 - 108, the former fragment: Cu 92.70% and Sn.2.19 % and the latter Cu 92.53 % and Sn 1.70% Both Pb around 0.70 % and Fe 1.7 - 1.8 %.

Foley 1988, 92 and note 116.

In my opinion, the handle also compares well with Maass no. 115 and the Kalapodi tripod B 642, cf. note 122 below.

NOTE 83

AH 2784 (NM 20817), AH II, 328, pl.-CXXXIV.

Found at Back of South Stoa, cf. note 23 above.

The width of the fragment is 4 cm., its depth 2 cm. at the handle strap and 0.9 cm. at the relief lines of the handle itself.

NOTE 84

Maass, 27 - 39. For the transitional phase, cf. esp. 33 - 34 with special reference to the leg from Ithome, pl. 67 (note 120 below) and to Maass, nos. 98 - 102 and 104. For the tripods in mixed style and technique, cf. p. 46 and note 87 below.

NOTE 85

Cf. note 119 below, Rolley 1973, no. 3.

NOTE 86

Examples of direct imitation in application technique of Matrice Tripods with metope decoration are Rolley 1977, 53, no. 189, pls. VI and XXXIV and the unpublished tripod leg fragment from Dodone in the Carapanos collection in the National Museum of Athens, no. 415, cf. Rolley, op. cit. p. 99, note 7. The fragment of the upper part of a leg shows three metopes placed vertically, of which only the central one is decorated with a wheel motif.

On the Matrice Tripod, Maass no. 115, multiple semicircles compose a horizontal border for the upper metope at the front of the leg. Cf. also Rolley 1977, no. 390, pl. XXXV

NOTE 87

Maass, 33 - 34, nos. 105 - 107, pls. 29 and 33. For the secondary join of the plate to the front of the leg of the Matrice Tripod, cf. Maass loc. cit. and Beil. 7 - 8.

For Maass, no. 121, cf. note 75 above.

NOTE 88

This observation was already made by S. Benton in *AJA* 1959, 95. Morgan 1990, 36 - 37, and Morgan 1993, 24, questions the conclusion. However, the evidence for Geometric bronze tripod manufacture at Olympia is certain and there is more than one example, cf. note 29 above. Morgan's demand for "evidence in quantity" does not seem reasonable today when the evidence for early bronze working is still limited, although rapidly increasing. Also the manufacture of such large objects may have taken place immediately outside the sanctuaries rather than inside (cf. e.g. the casting of the large Classical bronze statue on the South Slope of the Acropolis of Athens, note 29 above). According to Maass, 105 - 106, only Olympia gives evidence of working artisans. However, at most of the sanctuaries with Geometric tripods, there are signs of early bronze working on the site, cf. note 29 above, and at Kalapodi also evidence of local manufacture of hammered tripods, cf. note 127 below.

NOTE 89

Cf. p. 42 and notes 63 and 64 above and note 119 below, Ithaca no. 6, for a handle which apparently is transitional between the two subgroups and note 120 below for a handle at Delphi which seems to combine Matrice Tripod features with a handle figure of a bird.

NOTE 90

Willemsen, 99 - 105 and Maass, 48 - 62 and 172 - 178, nos. 174 - 200, pls. 44 - 46 and Beil. 19.

Maass, 48, shows that the rib handles formerly connected with these tripods belong to the Relief Tripods, whereas the step handles which formed part of Willemsen's "Treppenhaken" are actually the handles of the Tripods with Fanned Grooves. For the handle figures, cf. Maass, 58 - 61 and nos. 198 - 200. One Delphi handle has traces of soldered handle figures, cf. note 112 below, Rolley 1977, no. 456.

NOTE 91

AH 2219 (NM 20629 α). AH II, 294 - 295 and pl. CXXIII.

Maass, 53 with note 11.

Rolley et. al. 1986, 126 - 127 and 134, no. 105. It differs considerably from the other AH metal analyses in having only 84.43% Cu, but 8.97% Sn. Pb is 1.71 % and Fe 0.22%

Rolley C. 1992, 42.

The largest depth of the tripod is 2.8 cm. and the thickness of the plate varies between 0.3 - 0.4 cm.

NOTE 92

Cf. Maass loc. cit.

NOTE 93

Willemsen, 110 - 156 and Maass, 63 - 104 and most studies in note 44 above.

NOTE 94

NM 16555. Blegen 1939, 427 - 428 and fig. 16, cf. *IS I*, 192 - 193, fig. 16 and note 139. Presumably originally placed on the Old Temple Terrace.

NOTE 95

AH 1748 (NM 20676 α). AH II, 270, pl. CII.

NOTE 96

AH 1749 (NM 20676 β). AH II, 270, pl. CII.

From West Building, cf. note 21 above.

For supports in Olympia, cf. Willemsen, 135 - 136 and Maass, 66 and 200 - 201, esp. no. 227 b, pl. 48, no. 203 f and g, pl. 49 and 203 h (= *Ol. IV*, pl. 36, no. 675), no. 275 (= Willemsen, pl. 72), nos. 274 and 277, pl. 56 and no. 292 a (= Willemsen Br. 10535, pl. 84).

NOTE 97

Cf. note 94 above.

NOTE 98

Cf. references *IS I*, 193, note 139.

NOTE 99

Cf. references note 94 above.

NOTE 100

Kunze 1952, 6 - 7, figs. 4 - 5, cf. Maass, 55 - 58 and p. 174, no. 179 with other references. Cf. also Rolley 1983 a, 55, fig. 31.

NOTE 101

Felsch 1987, 11 - 12, B. 2600, fig. 17; the handle was found in a context dated to shortly after 850 BC, but no tripod finds are mentioned in the securely dated, later strata, 12. Cf. also note 214 below for the Kalapodi stratigraphical results.

NOTE 102

Coldstream 1977, 336 and Schweitzer 1969, 198, Maass, 110 - 111 and Maass 1981, 17. Against the dating by Maass, 112, of the terracotta leg from Perachora which imitates a Matrice Tripod (cf. p. 52 and note 123 below) to not later than the third quarter of the 8th Cent. BC, based on its context in the Hera Akraia votive deposit, cf. Felsch 1980, 62 - 63 note 103. Felsch is definitely correct in his observation that the deposit contains Egyptian fayence scarabs and Phrygian-type fibulae which rule out such an early date.

NOTE 103

For identical construction of the legs of the two groups of tripods cf. pp. 43 and 47 and references note 90 above. Both groups also have figured metope decoration, compare e.g. Maass nos. 116 - 117 with no. 179, cf. Maass, 55 - 56.

NOTE 104

Cf. Maass 1977, 34, note 14 and Maass, 105 with references to AH 11, 14 and 16 and cf. p. 56 and note 151 below. I excluded AH 14. For the chronology of the Geometric quadruped bronzes at the Argive Heraion, cf. pp. 55-56 and 57-58 and notes 150, 160 and 167 below.

NOTE 105

For the relative chronology of Solid Cast Tripods, Subgroup II, cf. p. 42 and notes 61 and 63 above. Handle figure NM 16551 is relatively the earliest of the finds from the Argive Heraion and the type of handle to which it belongs is late in its class, cf. p. 42 and notes 65 - 66 above and the leg, AH 2218, is at the point of transition to the Relief Tripods, cf. p. 43 and notes 69 - 70 above.

NOTE 106

The two tripod fragments are NM 16551 and 16555, cf. notes 65 and 94 above and IS I, 193 - 194. As suggested loc. cit. the

hammered tripod may have been placed here as a votive offering but it may also have had a function in the cult of the Temple. For the proposed cultic function of some of the early monumental bronzes, cf. also IS II, 55 - 57.

NOTE 107

For the function of Geometric bronze tripods in the sanctuaries, cf. e.g. Herrmann 1966, 1 and Coldstream 1977, 181 and 334 - 335.

From the 5th Cent. BC, there is an example of a bronze tripod among the bronze vases given as prizes at the Argive Hera contests, cf. Amandry 1980, 212 with note 7 and p. 251, and Andronikos 1984, 165 - 166, figs. 133 - 134.

For the iron tripod in Isthmia, cf. note 43 above and for the Corinth tripod, note 122 below.

For ritual purification with water in the sanctuaries, cf. Isthmia IV, 1987, 27, with references, note 47. For ritual purification at the altars, cf. Nilsson 1941, 92 - 93.

NOTE 108

The tripod finds from Tiryns and Mycenae are usually regarded as Mycenaean, although their possible Protogeometric date is also discussed, cf. Matthäus 1980, 118 - 121, cf. pp. 56 - 59 and 110 - 113. Cf. note 46 above.

The hammered tripod fragments in the Nauplion Museum, cf. note 131 below, have no certain provenance.

The terracotta tripod from Argos, Courbin 1966, 250, no. AR 263, Larissa. The other terracotta fragments mentioned here are either miniature or not certain tripod fragments.

NOTE 109

Cf. Maass 1977. Outside Crete, the Cretan tripods have been found at the sanctuary of Athena Lindia on Rhodes, at Amyclae and at Delphi, cf. op. cit. p. 34, notes 7 - 9; Maass, 4, note 24, and Rolley 1977, 42 - 43, nos. 336 - 345 and possibly 333 (legs) and pp. 65 - 66 nos. 458 - 63 (handles), pls. III - IV, VIII, XXVI - XXVII and XLV. In his discussion, p. 103 - 104, Rolley notes that there do not seem to be certain Cretan tripods at Olympia.

Athens NM 8008, from Amyclae, is considered a Cretan tripod by the above scholars. Also, NM 8009 seems related to Cretan tripods. It is a relief tripod fragment with a central vertical zigzag framed by vertical relief lines. It certainly does not belong among the Olympia classes. Calligas 1992, 35 and 42 and fig. 13 a.

NOTE 110

Weber 1971, 19; Willemsen, 179; Coldstream 1977, 337; Maass, 59 - 60 and Maass 1981, 18. Although Rolley 1977, 104, note 1, apparently disagrees with the attribution, he has later accepted it, Rolley, 1983 a, 55 and 60, and Rolley 1992, 40, where he advocates a Corinthian origin especially because of technical criteria regarding the horses of the handles.

NOTE 111

The handle figures are identified by Maas, nos. 198 - 200, cf. note 90 above. Although these horses have some Corinthianizing traits, e.g. the angular outline of their legs, I cannot agree with Maass, 59 - 60, in his view of their genuinely Corinthian style, such as it was identified by Herrmann 1964, 28 - 29. Their necks and legs are not flat and the outline of the neck does not continue into the lines of the ears which do not have the ordinary Corinthian high, forward curve. Their bodies are not cylindrical, their muzzles differ from the Corinthian trumpet-like ones and they have an open horizontal mouth.

NOTE 112

Tripods with Fanned Grooves.

Argive Heraion

AH 2219, cf. p. 48, Fig. 14 and note 91 above.

Delphi.

Rolley 1977, 56 - 57 and 65 - 66, nos. 405 - 410 and 456 - 457 (pls. VI - VII, XXXVI, XLII and XLIV) and Perdrizet 1908, 62, no. 208, fig. 191 ("verschol-len", according to Maass, 53, note 9.) Rolley, no. 456 shows remains of soldered handle figures of a horse and horse leader.

Ithaca.

Benton 1938 a, 62, nos. 10 (fragment of leg) and 12 (fragment of handle), pls. 10 e and 17 f.

Olympia.

Cf. note 90 above.

NOTE 113

Cf. note 91 above and Rolley et. al. 1986, 126 - 127 with references to metal analyses of the examples at Delphi and Olympia and cf. Rolley, 1992, 42.

NOTE 114

Weber 1971, 18; Willemsen, 179; Maass, 105; Coldstream 1977, 335 - 336 and Heilmeyer 1979, 27 - 28 and 54. Rolley 1977, 103 - 104, does not give a more specific attribution than "Peloponnesian". However, Rolley 1992, 40 - 41, now assigns the main part of the Relief Tripods

(as well as of the Solid Cast Tripods) to Argos, but assigns part of the Matrice Tripods, those with wheel-formed ornaments in the metopes, to Corinth, cf. note 78 above and, in fact, attributing most cast tripods from the Argive Heraion to Corinth.

NOTE 115

Cf. Weber 1971, 17; Willemsen, 180 and Maass 106.

NOTE 116

Heilmeyer 1979, 12, 27 and 54, and Kilian - Dirlmeier 1985, 230 - 236. Kilian-Dirlmeier does not give detailed references but her text shows that she accepts only Athens (Hammered Tripods), Corinth (Tripods with Fanned Grooves) and Argos as production centres of Geometric bronze tripods. Also, Rolley 1992, 41, now attributes the Solid Cast tripods to Argos.

NOTE 117

Cf. pp. 40 - 42 and 46 - 47.

NOTE 118

Provenances as a criterion for production centres was first advocated by Weber 1971, 17.

NOTE 119

Solid Cast Tripods. Subgroup I.

Aigeira.

Alzinger 1978, 151 - 152, fig. 4.
Alzinger 1981 - 82, 12, fig. 4, cf. Klio. 67. 1985, 449 - 450, fig. 43 (Reconstruction). Fragments of legs and handles. They are compared with Maass no. 1 and Ithaca, nos. 1 and 2, cf. below, this note. Only a few fragments seem to be preserved, but apparently without decoration; traces of an element inside the handle are reminiscent of the handle figures of some Subgroup I tripods cf. p. 41 and note 55 above. Found in a LG/Early Archaic context, inside a pot.

Delos.

Rolley 1973, 491 - 493 and 500 - 504, nos. 2 - 3, figs 3 - 5 and 7. According to Maass' definition, cf. note 70 above, nos. 2 - 3 should be regarded as Relief Tripod legs, but technically they are still solid cast, cf. sections, fig. 7.

Delphi.

Only very few tripod legs from Delphi have the above ornamental characteristics of Subgroup I and the fragments are, in general, badly preserved. Cf. Rolley 1977, 31 - 42 and 60 - 64, nos. 275, 298, 307, 314 and 330 (both the last two fragments have sections transitional to Relief Tripods), the handles, 429 - 437 and 454 and

possibly 464, pls. I - III, VII - VIII, XVIII, XXI, XXV, XXXIX - XLI, XLIII and XLV. (No. 454 is an exceptional piece, the handle figures of which are secondary, placed there in connection with a repair, cf. op. cit. pp. 64 - 65 and 80 - 81, fig. 11). The open work handles nos. 460 and 465 - 466 are - just like the open work handles from Olympia - difficult to place, cf. above note 62.

Ithaca.

Benton 1938 a, 56 - 66.

Nos. 1, 1a and 2 were found together and form one group (pp. 57 - 58, figs. 8 and 14 and pl. 10 a - d.).

No. 3 (pp. 58 - 59, figs. 6, 9, 15 and 18, pls. 11 a, 13 a, 14 d - e and 15 a). However, only the leg originally belongs to this tripod. The handle is a Relief Tripod rib handle. The cauldron was found with both leg and handle attached (cf op. cit. p. 93). Benton observed, pp. 58 - 59, that "The caps of the rivets are enormous, and there are layers of thin bronze between them and the plate. This probably indicates a succession of new vessels each leaving a skin behind". Presumably the leg of a Solid Cast Tripod was at some later date fastened to a cauldron with rib handles. The rivet holes of the handles are also secondary. Nailed figures from rib handles are not known in either of the Relief Tripod groups, cf. pp. 44-45 and notes 74 and 77 above. Apparently, horse figure no. 16 was riveted to the handle, pl. 15 d, and Benton, p. 63, also connects the second horse, no. 17, pl. 15 d with the tripod. However, I fail to see how the male statuette on a base, Benton, no. 15, Fig. 12 and pl. 16, can be attached to the rib handle, as suggested by Benton, pp. 62 - 63.

No. 6 (Benton, pp. 59 - 60, figs. 16 and 18, pls. 12 b, 13 c and 15 b) and possibly also the bull, no. 18 (p. 66, pl. 13 c and 14 a). On top of the handle is a horse and inside the handle a bull. Although solid, the handle with applied zigzag decoration seems to belong to a transitional stage to open work handles of Application Tripods. Several of the cauldrons were found together with both handles and legs, Benton, p. 93, nos. 3 and 9 have certain find contexts, nos. 6 and 7 probable ones, as well as the group nos. 1, 1a and 2. Cf. also Rolley 1977, 16, with notes 5 and 6. However, the many repairs of the tripods present a serious difficulty in reconstructing the original appearance of the tripods from Ithaca.

Kalapodi.

B 2600. Felsch 1987, 11 - 12, fig. 17. For chronology, cf. note 101 above.

Olympia.

Cf. notes 54 - 57 above.

Philia.

Athena Ithonia. Unpublished. Cf. Maass, 16, note 27 a, handle fragment like no. 53.

Thermon.

Inv. No. 61. Handle, cf. Maass, 18, note 46, counterpart to Maass, no. 63, pl. 23.

NOTE 120

Application Tripods.

Delos.

Rolley 1973, 494 and 501, nos. 6 - 7 and figs. 6 - 7. Cf. also note 119 above, Delos, Nos. 2 - 3.

Delphi.

Rolley 1977, 46 - 69, nos. 359 - 389, (no. 389 imitating Matrice Tripods with wheel ornaments), 393, 467 and 470 and the handle straps nos. 471 - 475 and 479, pls. IV - VI, XXIX -XXXIV and XLVI - XLVIII. For no. 454, cf. note 119 above.

Apart from its bird figure, handle no. 468, with its rather large zigzags might be considered a Matrice Tripod handle; but also its handle straps differ in ornamentation from those of the Matrice Tripods. Perhaps this tripod, like the tripods from Olympia, is a result of the meeting of bronze workers from different regions at the Panhellenic sanctuaries, Maass, nos. 105 - 107, cf. p. and notes 87 - 88 above.

Dodone.

Cf. note 86 above.

Ithaca.

Benton 1938 a, 60 - 62 and 66 - 67, no. 7. (Fig. 11 and pl. 11 b and 12 a and c.), p. 61, no. 8 (fig. 16 c) and No. 9 (figs. 17 - 18, pl. 11 c, 12 d, 13 b and 14 c (handle and legs found attached to cauldron, cf. note 119 above) 15 c and 17 e (cf. JHS 1950, pl. IV b) and p. 62 no. 11 (pl. 17 a - b). (According to Maass, 35 and Benton, loc.cit., the tripod leg, no. 11 is in matrice technique. Benton compares it with AH 2221 (cf. pp. 44-45, Fig. 8 and note 78 above), apparently because of its metope decoration. However, the side of the leg has multiple semicircles along its whole length, a decorative feature which is not paralleled in any Matrice Tripod, except for a very restricted use and metope decoration is also sometimes found on Application Tripods cf. p. 46 and note 86 above. The rib handle of no. 3, cf. note 118 above, presumably originally belonged with an Application Tripod, as there are no certain finds of Matrice Tripods on Ithaca.

Ithome in Messenia.

Athens. Mus. Benaki, no. 760. Unpublished, cf. Maass, 33, note 57 and pl. 67.

Laconia.

Athena Chalkioikos. Sparta.

Benton 1929 b, 128 - 129, fig. 17 d, handle fragment.

Op. cit. 129, fig. 17 a, terracotta imitation of a leg, probably in application technique, from Amyclae.

Mon Repos. Corfou ?

M 517. ADelt 19 1964, 324 and pl. 364 d.

It is a very small fragment with zigzag ornamentation and dog-tooth pattern and may come from either a Matrice Tripod or an Application Tripod, cf. e.g. Maass nos. 99 - 100 or 104 and Delos, no. 3, p. 46 and notes 85 and 119 above. Maass, 33 - 34 notes the difficulty in distinguishing the two subgroups with only a small fragment.

Olympia.

Cf. notes 73 - 74 above.

Unknown Provenance.

Maass, 32, Beil. 20.

NOTE 121

Solid Cast Tripods. Subgroup II.

Argive Heraion.

NM 16551, AH 2218 and 2220, cf. pp. 42 - 43 and notes 65, 67 and 69. above.

Delos ?

Rolley 1973, no. 1, pp. 491 - 492 and 500 - 501 and 522 - 523, figs. 1 - 2 and 7. and no. 4, pp. 493 and 501, figs. 3 and 7.

Delphi.

Most of the Solid Cast Tripod legs at Delphi are too fragmentary and too battered for definite classification but many recorded by Rolley 1977, 33, 40 - 47, 62 and 150, nos. 274 - 358 may belong here. For the handles, cf. Nos. 438 - 441 (For no. 442 cf. note 64 above) and no. 518, pls. I - IV, VII, XIX, XXIII - XXVIII and fig. 65.

The leg fragments are, in general, unconnected with other parts of the tripod.

Kalapodi.

B 26. Felsch - Kienast 1975, 19 and p. 12, fig. 18 and BCH 1975, p. 637 and 639, fig. 105.

Olympia.

Cf. notes 58 and 62 above.

NOTE 122

Matrice Technique Tripods.

Argive Heraion.

AH 2221 - 2224 and 2784, cf. pp. 45 - 46, Figs. 8 - 12 and notes 80 - 83.

Corinth.

Unpublished. Two fragments were found on the N side of the Apollo Temple, MF 72 - 163 and MF 72 - 165, presumably from the same tripod.

MF 72 - 163 is a small fragment of the upper part of a Relief Tripod leg in Ma-

trice Technique with an upper metope decorated with an inner circle, below which is a horizontal zigzag pattern and remnants of the vertical frame of the decoration. The fragment measures 5.7 x 2 cm. MF 72 - 165 is a small fragment of the solid middle section of an open work handle with large zigzags, measuring 4.2 x 1.6 cm.

Both fragments have the same reddish brown patina.

Cf. Rolley 1983 b, 332 and Rolley 1992, 41.

Delphi.

Rolley 1977, 54 - 58 and 68 - 69, nos. 390 - 392, 394 - 404, 453, 469 and 480, pls. VI, VIII, XXXV - XXXVII, XLII and XLVII - XLVIII.

For Rolley, no. 468, cf. note 121 above.

Isthmia.

Inv. No. 2826. Maass, 25 and note 30 (tripod leg with the same matrice as Maass, no. 110, cf. note 80 above.

Kalapodi.

B 9, Felsch - Kienast 1975, 19 and 12, fig. 19 (handle); B 472 and B 642, Felsch 1980, 60 - 62, figs. 33 - 34 (handles, the former compared with Willemsen, pl. 57, the latter an open-work handle with handle strap in matrice technique with zigzag ornaments and on top of the rim remains of a soldered horse with long tail and a horse leader) and B 643 (tripod leg), loc.cit. fig. 35. Same matrice as Maass, no. 109, cf. note 80 above.

Mon Repos. Corfou ?

Possibly Application Tripod fragment, cf. note 120 above.

Olympia.

Cf. notes 75 - 77 above.

The tripod from Ithaca which is often mentioned as being in matrice technique, I regard as definitely an Application Tripod, cf. note 120 above.

NOTE 123

Perachora I, 55 and pl. 14, 6 and 124, 1. Miniature terracotta tripod. One leg and part of adjoining bowl preserved. H. 18.5 cm. Cf. note 102 above, for absolute chronology.

NOTE 124

Corinth

Cf. note 122 above.

(The handle figure from a hammered tripod, Athens NM 7729, the provenance of which is often given as Corinth, has no certain provenance, cf. Rolley 1969, 26, note 6 and Rolley 1977, 104, note 2).

Isthmia.

The Matrice Tripod leg, cf. note 122 above.

No. IM 2224, Hesperia 1959, p. 327, no. 1, pl. 67 a. (Handle support from a hammered tripod, presumably Attic).

Perachora cf. the terracotta imitation of a tripod leg, note 123 above.

NOTE 125

Cf. p. 50 and note 104 above.

NOTE 126

Maass. no. 117, cf. Coldstream 1977, 336. Horses tied to throughs with an object above their backs or horses with riders standing on their backs, throwing spears, are known from other Greek regions, cf. e.g. the Boiotian vase, Copenhagen NM 5371, Coldstream 1968 pl. 45 a, for the former motif and the Boiotian fibula, Berlin 8396, for the latter, Hampe 1931, 11 and fig. 1; (detail = Wiesner 1968, F 121 and fig. 23 b). However, the rectangle above the back of the horse is definitely an Argive detail, as observed by Coldstream.

NOTE 127

Cf. note 29 above and the fragmentary handle support for a hammered tripod, B 1550, which is a rejected miscast, Felsch 1983, 123 - 124 and fig. 1.

NOTE 128

Cf. pp. 45 - 46 and notes 80 and 88 above.

NOTE 129

For Athenian production of hammered tripods, cf. almost all papers, note 44 above, but especially Karouzos 1952, Touloupa 1972 and Weber 1974.

A very good summary of the evidence is given by Rolley 1977, 100 - 102.

Also cast tripod fragments were found at the Athenian Acropolis, cf. op. cit. 135, note 7. According to verbal communication by P. Kalligas, they are too fragmentary for classification.

NOTE 130

According to Rolley, loc. cit., the greater part of the hammered tripods from Delos, Delphi and Olympia are Attic, whereas some of the finds at Delphi, as well as the Dodone tripod differ and presumably come from other workshops.

Cf. also the evidence for manufacture of hammered tripods at Kalapodi, note 126 above.

NOTE 131

Hammered Tripods.

Amyclae.

Buschor - v. Massow 1927, 15 and 36, Beil. VII, 3. (Fragment of tripod leg.) Cf.

Calligas 1992, 42 and note 78.
Zimmermann, 135, 166 and 168, LAC 172, NM 7774 and Calligas 1992, 42 and fig. 13 c. Horse figure from hammered tripod handle. Zimmermann regards it as probably local; apart from its lack of incised details, it appears close to Zimmermann ATT 1 from Olympia, although it is more slender and has a different rendering of the ear. ATT 1 differs considerably from the other horses of hammered tripods in Zimmermann's Attic group.
Cf. Calligas 1992, 34 and 42, for several other fragments of hammered tripods at Amyclae: five fragments of legs (X 17550 and 17554 - 17557) and one small rod from the fastening of a hammered handle (X 17541) as well as fragments of several hammered cauldrons.

Argive Heraion.

NM 16555 and AH 1748 - 49, cf. pp. 48 - 49 and notes 94 - 96 above.

Argolid. Museum of Nauplion.

(without certain provenance).

Willemsen, 140 with note 1 and pl. 72 above (fragment of leg) and pl. 81 above (fragment of handle).

Athens.

Cf. references note 129 above.

Delos.

Rolley 1973, 496 - 500, nos. 8 - 14, figs. 8 - 11.

Delphi.

Rolley 1977, 71 - 75, nos. 481 - 502, pls. XLIX - LI.

Dodone.

Cf. references, Maass, 231. In the National Museum of Athens and the Museum of Joannina. Cf. Rolley 1977, 102.

The handle figures are definitely not Attic.

Isthmia.

Cf. note 124 above.

Kalapodi.

Cf. note 127 above.

Olympia.

Willemsen, 110 - 156, pls. 68 - 88.

Maass, 63 - 104, nos. 201 - 322, pls. 47 - 56.

Philia.?

Handle figure of horse.

Christiansen. 1992, 64 - 65 no. 30.

NOTE 132

For fragments of Geometric/Early Archaic Attic vases at the Argive Heraion, cf. e.g. AH II, pl. LVII, nos. 13 and 22 and pl. LVIII, no. 4 and p. 161 and pl. LXVII; however, no. 4, a conical stand, is attributed to an Aeginetan workshop by Morris 1984, 12, 19 - 20, 70 - 72 and pl. 17. The Attic-Boiotian plate fibulae at the Argive Heraion are of the LG Boiotian type

and presumably Peloponnesian, cf. pp. 74 - 76 and notes 252 - 256 below.

NOTE 133

Herrmann 1964. For the Argive Geometric style see esp. 24 - 28.

NOTE 134

Of the many studies since Herrmann's work, I have used the following in particular:

Gehrig 1964, esp. pp. 48 - 57; Himmelmann 1964; Rolley 1969;

Schweitzer 1969, esp. 133 - 173; Coldstream 1977 *passim*, Argive bronzes, esp. 149 - 152; Rolley 1977, 5 - 7 (Addenda to Rolley 1969); Heilmeyer 1979 (esp. chpt. IV, 54 - 72, Tierfiguren aus argivischen Werkstätten in Olympia. and chpt. V, pp. 73 - 86, Argivisch - olympische Tierfiguren) (Cf. reviews, Herrmann 1982 and Rolley 1983 b); Schmalz 1980 a, esp. 22 - 36;

Floren 1987, esp. 44 - 51; Foley 1988, 89 - 94;

Zimmermann, esp. 18 - 59. Argolid. In my notes of the relevant statuettes from the Argive Heraion I shall give references only to AH and to Zimmermann who gives all earlier references).

Voyatzis 1990, esp. 103 - 174; Vogt 1991, 60 - 64;

Croissant 1992.

See also Arcadian bronzes note 139 below.

NOTE 135

Cf. p. 42 and note 65, Fig. 3 above.

Langdon 1984, 264, observes that several Hera sanctuaries show a preference for animal over human bronze statuettes in the Geometric Period. (I owe the reference to Blanche Menadier).

NOTE 136

AH 8 - 20 and NM 16970 and the three horse statuettes said to have been found at the Argive Heraion, note 10 above.

The Altar site: NM 16551 (cf. ref. note 14 above).

The Old Temple Terrace: AH 20 (cf. ref. note 15 above) and presumably also NM 16970, as it was found in a trial trench along the western facade of the Terrace (Blegen 1939, 432 and fig. 18 and Antonaccio 1993, pl. 24 a, cf. note 138 below). The fill west of the Classical Temple: AH 15 and unidentifiable horses and bases (cf. IS I, 201).

The Gymnasium: unidentified horse (cf. note 13 above).

Northeast Stoa: AH 14 and 17 (cf. note 17 above).

West Building: AH 19 (cf. note 21 above). Northwest Building: AH 12, 16 and 22 (cf. note 24 above).

Back of South Stoa: AH 8 (cf. note 23 above).

NOTE 137

Kilian 1979.

NOTE 138

Central Greek cf. note 10 above.

Hannover. Kestner Museum. Inv. No. 1928. 264.

Corinthian-Laconian.

For Herrmann's criteria of Corinthian style (based on the finds from Perachora and from Ithaca) and of Laconian style (based on the finds from the Artemis Orthia sanctuary) cf. Herrmann 1964, 28 - 32 and 21 - 24, respectively. As regards the rectangular statuette base plates from the two regions, both differ from the Argive Heraion base plates in being pierced; the Laconian ones have a projection.

Corinthian.

AH 19. (NM 13951), deer, AH II, 200 - 201, pl. LXII, cf. Herrmann 1964, 29, note 52; Heilmeyer 1979, 65, note 18 and Rolley 1969, 75; Rolley et. al. 1986, 128 and note 11 and Rolley 1992, 46.

AH 8 (NM 13985) and AH 9 (NM 13977), horses, AH II, 197 - 198 and pl. LXXII; Zimmermann, nos. ARG 100 and ARG 96, pp. 25 and 44 - 45 and pl. 7, with their cylindrical bodies and flat legs, in the former figure with distinct protrusions of the legs, are also Corinthian. In spite of the information, AH II, 197, that the non - Corinthian base plate of AH 8 broke off during cleaning, the figure of AH 8 cannot belong to this plate, on which the traces of the hooves are circular and even rather incrustated on top.

Laconian.

The horse NM 16970 cf. note 136 above and Zimmermann LAC 158, p. 134 and 163 is Laconian in style and has a Laconian base plate. I do not follow Zimmermann's views, loc. cit., of Argive influences. The two horses in the Ashmolean Museum Inv. Nos. 1894,120 and 121, are presumably both Laconian, although one may be Arcadian under Laconian influence, cf. note 10 above.

NOTE 139

Arcadian Bronze Figures.

Weber 1967 (the first definition of the so-called Lusoi -Mantineia Group); Heilmeyer 1979, 99 - 107 (Heilmeyer, however, does not consider his Olympia - Lusoi Group as Arcadian and calls it: Argivisch - Arkadis-

che Arbeiten. In his review of Heilmeyer 1979, Herrmann considers the group Argive. Herrmann 1982, 616). Sinn 1980 (here Mantinea as a certain provenance besides Lusoi); Bol 1985 a; Floren 1987, 57 - 58; Zimmermann, 91 - 113. Zimmermann, however, places most horses of the Lusoi - Mantinea Group in his Argive school, nos. ARG 66 - 90, and a few under Laconia, e.g. LAC 149; Voyatzis 1990, 103 - 174, the Lusoi - Mantinea Group esp. 133 - 139. Conclusions, 138. The studies of M. Weber and U. Sinn especially give evidence of a large and stylistically well defined group of bronze statuettes, having only Lusoi, Mantinea and Olympia as their finding places and with particularly rich finds at the first site. For bronzes from Tegea, cf. esp. Voyatzis, 127 - 133 and p. 57 and note 163 below.

NOTE 140
Cf. Voyatzis loc. cit. and p. 58 and note 172 below.

NOTE 141
Herrmann 1964, 26 - 28 and p. 33 - 39. Cf. esp. Heilmeyer 1979, 54 - 55, Floren 1987, 44 and Zimmermann, 19.

NOTE 142
Cf. pp. 51-52 above, the Solid Cast Tripods, Subgroup II and the Matrice Tripods.

NOTE 143
E.g. Zimmermann's Argive school, pls. 1 - 11, includes horses which represent almost all regional styles, cf. note 10 above for the Central Greek style and note 139 for the Arcadian style and, in general, note 184 below.

NOTE 144
Rolley 1969, 75.

NOTE 145
Cf. Heilmeyer 1979, 104, fig. 6 and Voyatzis 1990, fig. 27 for different Arcadian types of ornamentally decorated solid base plates and the latter, pls. 69 - 70, B 21, L 4 and 5, for presumably Arcadian horses with pierced base plates, as well as note 149 below for pendant plates with incuse decoration.

NOTE 146
AH 15, cf. p. 57 and note 161 below.

NOTE 147
The suggestion that the undersides of the base plates of Geometric bronze statuettes

were used as stamps or seals, cf. Zimmermann, 316 - 317 with earlier references, cannot easily be applied to the Argive Heraion material. I agree with Himmelmann 1964, 27, that in most cases, the simplicity of the design or the size of the base plate make such a function appear unlikely.

NOTE 148
AH 12 (NM 13947) and AH 13 (NM 13943), AH II, 198 - 199, pls. LXXII - LXXIII. = Zimmermann nos. ARG 128 - 129, p. 27 and 49 and pl. 10. Cf. also Foley 1988, 90 and pl. 16 and Vogt 1991, 62 and 64 and figs. 35 (AH 13) and 40 (AH 12). AH 12 H. 7.65 cm, L. 6.9 cm, L. of base 4.8 cm. Forelegs broken and partly missing. Surface worn.

For technical reasons Rolley suggests that AH 12 is Corinthian, Rolley 1969, 75; Rolley et al. 1986, 126, note 11, and Rolley 1992, 46, a theory which the base alone rules out. Cf. also note 154 below. AH 13 H. 6.6 cm, L. of base 4.85 cm. Tail missing. For its engraved decoration, cf. note 159 below.

NOTE 149
Dugas 1921, 353, no. 46, fig. 13 (Ref. from Herrmann 1964, 25, note 37). The statuette is missing. The figure relief of the base is from the same matrice as AH 13, although the left end has been cut off through the hind-quarters of the horse. A similar horse relief occurs on the base of a bird, Voyatzis 1990, B 53, pp. 152 - 153 and 315 and pl. 88 (Cf. Rolley 1969, 88). Voyatzis, 153, refers to a similar decoration of B 47; this, however, shows a horned quadruped in intaglio, cf. the illustration, K.-D. Anhänger, pl. 57, No. 1091. Also in intaglio is the striding man on the underside of the bronze scarab, Voyatzis B 185, pp. 197 and 337, fig. 27, as well as figures on several other Tegea pendants. Cf. K. D. Anhänger, nos. 165 and 167, 217 - 218, 236 - 237 and 244, pls. 11 and 14 - 15. I have not noted any other bases with figure decoration in relief in the museum of Tegea. For Arcadian base plates, cf. note 145 above.

NOTE 150
For corresponding horse figures on Argive vases, cf. e.g. Coldstream 1968, pls. 28 - 29, C 1 and Athens 231 and 877 (all LGII) and on stone seals, AH II, 346 and pl. CXXXVIII, 28 and Blegen 1939, 432, fig. 19 (= Foley 1988, 116 and 273, fig. 15). Cf. Boardman 1963, 116 - 121 and 129 -

130, esp. 119, Nos. C 3 and 8 and Zazoff 1969, 185 and Zazoff 1983, 58, with note 45, and pp. 59 - 61.

One more tie to the Argive Heraion is seen in a local seal ring of silver from Prosymna Tomb IX, the intaglio decoration of which repeats the motif of two animals face-to-face, divided by a cross line, Blegen 1937, 378- 379 and fig. 1. It is a cartouche ring with an oval bezel, the diameter of the ring measures 2.5 cm., the bezel 1.8 cm. in length. According to Blegen, it is crudely made and its intaglio decoration shows a horned animal to the left, a dog or lion to the right. (I have not seen the ring in the National Museum of Athens). The ring type is Egyptian and is supposed to have reached Greece around 600 BC via the Phoenician Mainland or Cyprus. (Boardman 1967, 5 - 7, fig. 4, Group A; Boardman 1970, 155 - 156 and fig. 198 A; Culi-can 1978, 139, no. 10 and figs. 14 - 16, cf. Hölbl 1979, 287 - 289 and Hölbl 1986, 339). However, the votive deposits of the Prosymna Tombs are dated to the late 8th and early 7th Centuries BC, cf. p. 91 and note 362 below, and for Tomb IX, also note 370, i.e. almost a century earlier than the suggested Phoenician or Cypriot models. The intaglio decoration of the ring is not Egyptianizing but genuinely Greek Geometric.

I would suggest that in form this local ring is a direct imitation of an Egyptian ring. During the period in question, there seem to have been relations between Greek Hera sanctuaries and Egypt. Cf. in particular, the bronze mirrors with inscriptions to the Egyptian goddess Mut from the Hera sanctuaries of Perachora and Samos which may indicate an identification of the two goddesses already at this time. The former mirror is dated to the early 7th Cent. BC (Cf. Munro 1969; Trolle 1979, 147 - 148 and IS II, 57). At the Argive Heraion, there is a 7th Cent. Egyptian Horus statuette in bronze (Blegen 1939, 437 and fig. 24).

NOTE 151
Cf. p. 50 and note 104 above and notes 153, 155 and 157 below. For the two statuette bases from the western fill, cf. IS I, App. 201.

NOTE 152
Cf. e.g. Zimmermann. ARG 80, pp. 24, and 40, pls. 5 and 73 and ARG 84, p. 24 (= Heilmeyer, no. 457, pl. 59). In both cases, the rather similar design is complete and seems to have been made for the specific base. Both horses belong to the Lusoi - Mantinea group, cf. note 139 above.

NOTE 153

AH 11 (NM13945), AH II, 198 and pl. LXXII = Zimmermann. ARG 105, pp. 26 and 45 and pl. 8; Foley 1988, 90 and pl. 16 c. H. 4.45 cm, L. 4.6 cm, L. of base 4. cm. Part of right hind leg missing. For the engraved decoration, cf. note 159 below. For **AH 12 - 13**, cf. note 148 above and note 159 below. For **AH 14 and 16**, cf. notes 155 and 157 below.

NOTE 154

Cf. Herrmann 1964, 24: "Der spannungsvoll bewegte Rückenkontur ... die eigentümliche Beweglichkeit vor allem der Beine". Statuette and base plate of the Argive Heraion animals were made of separate matrices joined in the mould. I have not observed traces of the very complicated technique used for Corinthian figures described by Heilmeyer (Heilmeyer 1979, 37; cf. Zimmer, 197 and cf. note 148 above, ref. to Rolley). Judging from traces on the front part of AH 16, cf. note 157 below, this may have been the place of the funnel (cf. Zimmermann, p. 51).

NOTE 155

AH 14 (NM13565 + 13994), AH II, 199 and pl. LXXIII = Zimmermann no. ARG 106, pp. 26 and 45 and pl. 8. The base plate is said to have broken off in cleaning. The same information was incorrectly given about AH 8 (cf. note 138 above). As the lower parts of the legs are missing, I do not see, how they could have broken off during cleaning. H. 4.1 cm. Base plate, L. 4.4 cm, Th. 0.2 cm. For Arcadian counterparts to decoration of base, cf. note 152 above. **AH 20 (NM 13968)**, AH II, 201 and pl. LXXIII; Heilmeyer 1979, 65, note 118 and 66, fig. 2; Zimmermann, 43, note 175. H. 4.1 cm. L. 4.5 cm. Base plate L. 2.9 cm. Th. 0.35 cm. Apparently the treatment of the Argive Heraion bronzes, cf. note 41 above, did not influence the patina in the same way as that of the other bronzes from the Argive Heraion. The incuse decoration of the underside of the base is essentially an Arcadian feature, but there is no exact Arcadian parallel for this large motif, possibly of a reclining ox.

NOTE 156

Cf. Voyatzis 1990, 140 - 142, pls. 74 -76, esp. B 23, 27 and 28.

NOTE 157

AH 16 (NM 13964), AH II, 200 and pl. LXXIII = Zimmermann ARG 97, pp. 25 and 44, pl. 7. H. 3 cm, L. 5.5 cm. Base plate L. 3.2 cm., Th. 0.2 cm. Tip of tail missing.

NOTE 158

Cf. notes 148 and 153 above and 159 below.

NOTE 159

The decoration of AH 13 is best preserved on the left side of the figure, but also partly visible on the right side, from a photograph of which the drawing fig. 19 was made. Just below the ears are two oblique, parallel lines of diminutive circles and on the forequarters the outline of a broad band is rendered in the same way with - in its centre - two parallel lines meeting in a small circle. (There are some chance lines and much damage, but no other certain traces of decoration). It is possible that AH 12 had a similar decoration as there seem to be faint traces on the neck and forequarters, but its surface is too worn to be sure. According to AH II, 198, AH 11 had an engraved line from ear to nose on either side of the head. Cf. especially Bohén 1988, 10 - 11 for similar painted rendering of bridles and broad protection band on the forequarters of horses of Attic Geometric pyxides and cf. e.g. op. cit. II 4, pl. 23. Cf. also Himmelmann 1992, 10 - 11 Textabb. 2 and fig. 3 = Zimmermann ATT No. 40, (cf. note 180 below). For illustrations of Geometric riding horses, cf. Wiesner 1968, esp. p. F 119 - 123. The circular ornament on the neck of AH 13 may possibly be a brand, although it was usually placed on the shoulders or the hindquarters, cf. Bohén, loc. cit. and Stubbe Østergård. 1991, 173 - 175, fig. 76.

NOTE 160

Cf. Rolley, note 144 above. For painted LG parallels to the horses on the bases, cf. note 150 above. For parallels to the horse statuettes, esp. their gently curving outline, cf. the reference by Herrmann 1964, 25, to the Tiryns sherd, fig. 5, and cf. e.g. Coldstream 1968, pl. 30 (Athens C 201), p. 145, dated to the very end of Argive LG, contemporary with Early Orientalizing elsewhere. On both these horses, the sex is rendered, but there are many Argive painted horses without this feature, in LG II as well as in Subgeometric and Early Orientalizing vase-painting, cf. e.g. Courbin 1968, pls. 8, 32 - 33 and 48, the first-mentioned vase coming from the Argive Heraion.

I do not quite see why Heilmeyer 1979, 65, note 118; Foley 1988, 90 and Zimmermann, 45 and 49, all regard AH 11 as notably earlier than AH 12 - 13. In my opinion, its posture is very close to that of the painted horses of Athens C 201. Coldstream 1977, 330, gives his absolute dates of Argive LG II as between ca. 730 and 690 BC. My dates around 700 BC are slightly earlier, cf. IS I, 178, note 46.

NOTE 161

AH 15 (NM 13962). AH II, 199, pls. LXXIII and CXXXVIII. The mane and the ears are indicated. The head is turned slightly to the right. H. 2.9 cm, L. 4.2 cm, L. of base 3.1 cm. Zimmermann, ARG 156, pp. 28 and 51, pl. 11.

NOTE 162

AH 10 (NM 13949). AH II, 198 and pl. LXXII = Zimmermann. ARG 95, pp. 25 and 43 - 44, pl. 7. H. 4 cm, L. of base 3.55 cm. The base is similar to the detached base of AH 8, cf. note 138 above. Voyatzis 1990, B 13, pp. 128 - 129, pl. 66 and fig. 27 = Zimmermann. ARC 70, pp. 94 and 103 - 104 and pl. 20. Voyatzis regards it, together with B 15, p. 129, pl. 66 = Zimmermann ARC 71, as possibly an Argive import, cf. note 163 below.

NOTE 163

A rather heavy type of horse is represented in several examples at Tegea. Voyatzis 1990, 129 and 131 - 132, B 14, B 18 and B 19 (and Dugas 1921, 345, no. 9, fig. 6) pls. 66 - 68. = Zimmermann, ARC 53, 59, 73 and 112. Voyatzis loc. cit. also connects B 16 (pl. 67 and fig. 27) from the Artemis Sanctuary near Mavriki with these horses. In my opinion, Voyatzis B 15, cf. note 162 above, belongs to the same group. These animal figures form one group within a rather large variation of animal types in Tegea, some of which show Laconian influences, cf. Voyatzis 1990, 129 - 130, B 19 - 21, pls. 68 - 69; however, B 20 is, in my opinion, correctly attributed to Laconia by Zimmermann, pp. 131 and 134, LAC 114, pl. 33. (B 17 mentioned by Voyatzis together with the above horse figures was actually found in Sparta = Zimmermann, LAC 163).

NOTE 164

AH 22 (NM 13466). AH II, 201, pl. LXXIV; Heilmeyer 1979, 65, note 118, here identified as a stamp or seal. K.-D. Anhänger, 187, No. 1137 A.

H. 1.4 cm, L. 2.35 cm, L. of base 1.45 cm. I do not follow I. Kilian - Dirlmeier in her classification of this pendant, seeing instead its counterparts in the following group: K.-D. Anhänger, nos. 1157 - 1162, pp. 193 - 194 and pl. 61 and p. 194, note 45, ref. to Dugas 1921, 342 - 345 and figs. 2 and 4, nos. 1 and 5 (two more bronze oxen of the same type, although without bored holes and thus not pendants). For the Tegea examples, cf. also Voyatzis 1990, 144 - 147, B 34 - B 37, pls. 78 - 80 and for the Olympia example, Philipp 1981, no. 1250, p. 351 and pl. 77.

NOTE 165

Christiansen 1992, no. 68. I.N. 3356, pp. 88 - 89. Ref. loc. cit. to stone seals AH II, 349, nos. 39 - 41, pl. CXXXVIII, and to stone seals from East Greece, especially Ephesos and Lindos.

NOTE 166

E.g. Heilmeyer 1979, 65, note 118, dates AH 11 to the 730's and AH 12 - 13 to the 720's. Rolley 1969, 72, dates the bronze figures from the Argive Heraion, in general, to the second half of the 8th Cent. BC, whereas Vogt 1991, 61 - 64, stretches the production over the whole of the 8th Cent. BC, even separating AH 12 and AH 13 for about a century, in spite of their closely related base reliefs. AH 13 (Cat. no. 225) is dated to the first quarter of the 8th Cent. BC, 62, and AH 12 (Cat. no. 243) to shortly before 700 BC, p. 64.

NOTE 167

Zimmermann, 10, refers to some contexts of chronological importance, Langdon 1984, 43 - 47, with notes 4 - 8. pp. 78 - 79 to others.

The sanctuaries are not informative in this connection. The find context of the **Kalapedi** horse, B 200, apparently does not yet allow an exact chronology (cf. Felsch 1980, 60 and fig. 31) and the two lion figures, Felsch - Kienast 1975, 19 and fig. 20 (B 39) and Felsch 1980, 59 and figs. 29 - 30 (B 125) are surface finds.

The Geometric bronze horses from **Perachora** were found only in the later so-called Hera Limenia deposit which lasted into the Archaic Period (cf. Coldstream 1977, 174). For a re-valuation of the Perachora sanctuary, dating the so-called Hera Limenia building and the activities connected with it to the 7th Cent. BC, cf. Tomlinson 1990, 330 - 333.

In the **Artemis Orthia** Sanctuary, the bronze figures were found in contexts from around 700 BC. and during the 7th Cent.

BC, cf. AO, 197: "Geometric... The well-known type of animal statuette... in the lowest layers of Geometric pottery, there were very few specimens... some lay among pottery of Laconian I only, while the bulk of them, as indeed of all the bronzes... lay in those layers which were marked by the presence of Proto-Corinthian pottery." By the revision of Laconian chronology from the chronology of the Menelaion, the excavators' absolute chronology for Lac. I is now only slightly lowered, cf. Cavanagh - Laxton 1984, 34 - 35 and Carter 1987, 358.

S. Benton published two important contexts, one Tomb 20 in **Bari** of a horse figure with an EPC aryballos, Benton 1950, 21 and pl. IV d (cf. ASAtene n.s. 21 - 22, 1959-60, 10 - 12, fig. 2) and the other on **Ithaca** of a Geometric horse found inside a Protocorinthian kyathos from around 700 BC, Benton 1953, 348, E 194, pl. 65 and the kyathos, no. 782, p. 294 and fig. 10.

Of Langdon's references, only the following seem to have importance in the present context:

Langdon, loc.cit. note 5.

Chamilavrissi near Thebes. Cf. Schmaltz 1980 b, 41 - 42, note 80 and pl. 24. A rich female burial with four bronze figures of deer and dogs, bronze pins and LG pottery from shortly after 750 BC. (ADelt, 26, 1971, B, 215 - 216 and pl. 188 (LG pottery) (Th. Spyropoulos).

Langdon, loc. cit. note 6. **Tomb near Thebes**. (Mem.Soc.Ant. 55, 1894, Ser. 6, Vol. 5, pp. 160 - 161) with a deer/fawn group and a lyre-player seal, (cf. Boardman 1966, 28, no. 53. Boardman 1990, 9, the whole group of Lyre Player Seals to the middle years of the second half of the 8th Cent. BC)

Langdon, loc. cit. note 8. **Kalamata**. (ADelt 20. 1965, B, 207 and pl. 213 B) (P.G. Themelis) A female burial in a pithos, a bronze horse found together with LG pins (Cf. K.-D. Nadeln, 130 sq., nos. 1459 - 60, pl. 50 (Geometric X) and p. 139, nos. 1612 - 13, pl. 54 (Geometric XV) In her discussion of the chronology of the former pin type, p. 131, I. Kilian-Dirlmeier refers to the statuette for the absolute chronology of the tomb, but she also states that the pins of Geometric XV are definitely LG.

Langdon, loc. cit. Bari. Cf. above.

The Anavra finds, Langdon, loc. cit. note 8, are not a certain closed context.

For contexts with bird figures, cf. note 214 below, esp. Amphikleia and Tiryns.

NOTE 168

Cf. notes 150 and 160 above.

NOTE 169

AH 17 (NM 13984 + 13986), AH II, 200 and pl. LXXIV.= Zimmermann, ARG 133, pp. 27 and 50, pl. 10. It is badly cast with a somewhat bubbled surface and a double mouth, presumably due to a casting failure. However, its mouth was definitely divided horizontally like that of other animals from the Argive Heraion. Its eyes were bored holes. H. with base 6.8 cm, L. of base 5.15 cm. Base plate detached, but belonging; on its top engraved ornamental decoration.

AH 18 (NM 13944), AH II, 200 and pl. LXXIV. Foley 1988, 92 and pl. 17. Vogt 1991, 157 and fig. 96 (Cat. no. 431).

H. 5.7 cm, L. 8 cm. Lower parts of legs and tails missing as well as base. Herrmann 1964, 28, note 42, dated it as late as the second half of the 7th Cent. BC and so does Vogt, loc. cit.

In my opinion, it is closely related to the group of larger horse statuettes published by Schilbach 1984, pls. 1 - 4, although Schilbach's chronology of this group within the Geometric or Subgeometric periods seems a little early to me.

NOTE 170

Bevan 1986, 319 - 337, esp. 335 - 336, emphasizes in her conclusions the variety of animal statuettes offered to each deity; however, although there is not always an obvious connection between the animal types offered and the individuality of the particular deity, she states that certain types of animals were discovered more frequently in sanctuaries of some deities than in others, a tendency which became more clearly marked during the Archaic Period.

The earliest known Greek representations in bronze of cows or bulls at the Argive Heraion are AH 23 and 25, imitations of Near Eastern cauldrons with bulls' heads, from the early 7th Cent. BC. Cf. most recently Muscarella 1993, 33. Presumably, the bull's head found by Rangabé and Burian, cf. p. 38 and note 11 above, also belongs to such a cauldron. The earliest bronze statuettes are the Archaic bulls, AH 24 and 26. AH II, 202 and pl. LXXV. For the latter, cf. IS I, 185, note 75.

NOTE 171

Cf. notes 150, 160 and 165 above.

NOTE 172

The one certain Arcadian bronze statuette at the Argive Heraion is, in my opinion, AH 10, cf. p. 57 and note 162 above. AH 20 is possibly Arcadian, cf. p. 56 and note 155 above. Probably also the missing stat-

uettes of the base plates of AH 8, cf. note 138 above, and AH 14, cf. note 151 above, were Arcadian. But the similarities between the two groups of bronze statuettes are great, as stated p. 53 cf. notes 139, 156, 162 -164 above and note 174 below.

NOTE 173

Voyatzis often stresses the presence of Laconian traits in Arcadian Geometric bronze figures, cf. e.g. Voyatzis 1990, 129 - 133 (Tegea), 138 (Lusoi and Bassai/Phigaleia) and 139 and 261 (Conclusions).

The Laconian influences are impressive, in particular in the groups from Lusoi and Bassai/Phigaleia. The evidence from Tegea seems less convincing. Voyatzis 1990, B 20 and B 21, pp. 130 - 131, pls. 68 - 69 are acquisitions by the Ashmolean Museum at a time when there were no excavations at Tegea and their provenance may not be reliable, whereas B 17 was actually found in Sparta = Zimmermann, LAC 163.

NOTE 174

Cf. most recently, Voyatzis 1990, esp. 128 - 139, with conclusions p. 132 and 138 - 139 and cf. note 139 above references to Heilmeyer (and review by Herrmann) and Zimmermann.

NOTE 175

Voyatzis 1990, p. 260 Conclusions: "The bronze objects... indicate the existence of Arcadian originality, creativity and a considerable distinction in style".

NOTE 176

Cf. references in note 77 above for the horse figures in question.

NOTE 177

Until now there do not seem to have been found fragments of Geometric bronze tripods in Arcadian sanctuaries. They are not published from the old excavations and according to verbal communication by Veronica Mitsopoulos-Leon and Erik Østby, they have not been found in either of the current excavations at Lusoi and Athena Alea at Tegea, except for a recent find of a fragment of a miniature tripod at the latter site. Voyatzis 1990, 102, concludes her discussion of the Tegea rim, B 203, pl. 145, by stating that it is a rim fragment of an ordinary bronze pot.

NOTE 178

Reciprocal stylistic influences would certainly take place if the idea of itinerant bronze tripod workers is correct, cf. pp. 46 and 52 and note 88 above. They might ac-

count for the definitely Argive stylistic detail on one of the metope reliefs of an Olympia Matrice Tripod, cf. note 126 above.

NOTE 179

Cf. note 149 above for finds at Tegea of Argive Heraion types of base plates. For the base plates of Geometric bronze figures found at Olympia, cf. Heilmeyer 1979, pl. 59 below (Lusoi - Mantinea Group), pls. 51 and 56 (Corinth) and pls. 66 - 67 (Laconia) and at Delphi, cf. Rolley 1969, pl. XVII.

NOTE 180

For earlier attributions, cf. e.g. Herrmann 1964, 25, notes 36 - 39. (Apart from the Olympia and Tegea finds, Heilmeyer 1979, 65, note 118, does not find Herrmann's contributions convincing) and Floren 1987, 45, notes 125 - 132.

The **Lusoi** figures form part of the Lusoi - Mantinea group, cf. note 139 above.

For the **Athenian Acropolis** figures, cf. Zimmermann, ATT 34 - 35, pp. 272 and 282, pls. 65 - 66. The **Sparta** horses, cf. Zimmermann, LAC 173 - 174, pp. 135 and 166, pls. 38 and 78, have non Argive base plates and the **Perachora** horse even has a pierced baseplate (cf. Zimmermann, COR 50, pl. 44 and Heilmeyer 1979, 99). The horse from **Kalaureia** = Zimmermann ARG 134, pp. 27 and 50, is a very static and plump figure and has, in contrast with the Argive Heraion horses, rendering of the sex.

For Herrmann's suggestion of Argive origin of the **Tegea** horse, Dugas no. 9, cf. note 163 above.

For the **Nemea** horse cf. and note 193 below.

Of the **horses in private collections**, I see no stylistic relations at all, regarding most of the attributions given by Floren, loc. cit. and find it worth while discussing only the following attributions:

Basel Schefold 1960, Cat. no. 59 = Zimmermann. ARG 131, pp. 27 and 49 with note 235. This horse figure has an Archaic Argive inscription, but the inscription must be a secondary feature and does not necessarily indicate Argive origin. The detail rendering of its legs is much more pronounced than in the Argive Heraion horses. Stylistically, it seems to me to be closely related to the horses of the Tripods with Fanned Grooves, cf. note 90 above, for which group of tripods I do not see any reason for connection with the Argolid, cf. p. 51 above. Also Schefold, loc. cit. No. 58 may be a horse from a Tripod with Fanned Grooves.

Bonn. Inv. No. C 74. Himmelmann-Wildschütz 1974, figs. 1 - 7 = Zimmermann 40, pp. 273 and 283 and pl. 66. Cf. Himmelmann 1992, 10 - 11, Textabb. 2 and figs. 3 and 9. Cat. no. 3, pp. 46 - 48. Its base plate is not Argive and, although not identical, it is reminiscent of some Arcadian base plates, e.g. Voyatzis 1990, B 29, fig. 27. In general, Arcadian base plates are very varied, cf. p. 54 and note 145 above. Its detailed features, such as the circular hollow eyes and the angular outline of its legs, do not find counterparts among the Argive Heraion horses and stylistically it seems closer to some Arcadian figures, cf. e.g. Voyatzis 1990, L 4, p. 134 and pl. 64. Nor are there any certain examples of figured tremolo decoration on Argive bronzes statuettes. I am inclined to consider it Arcadian, cf. p. 76 and note 256 below. Only the horse in **Frankfurt. Liebighaus**. Bol - Weber 1985, 12, Cat. no. 13 = Zimmermann. ARC 86, p. 96 and pl. 22 is, in my opinion, related to the Argive Heraion horses, although the hind legs have more pronounced details than usual. Christiansen 1993, 64 - 65, no. 31, a horse from **Philia** with its legs rounded underneath and thus neither a tripod horse nor a statuette with base plate, has many detailed features in common with the Argive Heraion statuettes, esp. its horizontally divided mouth. It seems to be one of the best candidates for an Argive horse.

As regards the human figures, our knowledge from the Argive Heraion is too vague for secure attributions. Except for the Argos warrior (cf. p. 61, Fig. 23 and note 189 below), I do not find the attributions of Geometric human bronze figures to the Argolid convincing.

NOTE 181

Cf. Heilmeyer 1979, 137: 55.3 % of all imported early animal bronze figures in Olympia are Argive.

NOTE 182

Cf. Heilmeyer 1979, 54 and Herrmann, 1982, 614. For the distribution area of the two subgroups of tripods, cf. p. 51 and *riotēs* 119 - 120 above.

NOTE 183

Heilmeyer 1979, chpts. IV and V. For the chronology of the Argive Heraion bronzes, cf. p. 57 above. Heilmeyer's own dates for the Argive Heraion bronzes are in no case earlier than the 740's, cf. Heilmeyer, 65, note 118. According to Heilmeyer, 137, about 50% of the published Geometric animal bronze

figures from Olympia attributed to the Argolid are oxen.

NOTE 184

Although Zimmermann's book is certainly an impressive contribution to the studies of Greek Geometric sculpture and his conclusions, in general, appear convincing, his Argive school is, in my opinion, rather confused, representing almost all Greek Geometric regional styles. His ARG nos. 1 - 23 are attributions based on handle figures of Solid Cast Tripods, Subgroup I and stylistically differ considerably from the Argive Heraion figures; most of his ARG nos. 24 - 36 and 136 - 155 are very inferior animals, presumably not always horses, for which I find any attribution doubtful; ARG nos. 39 - 40 have Laconian traits and the latter is placed on a pierced base; his ARG nos. 66 - 90 and possibly 91, cf. note 139 above; ARG nos. 108 - 114 and 119 - 126 are related to Central Greek horses cf. note 10, Hannover, above, and probably have the same origin.

The group ARG 46 - 58 has points of similarity to the Argive Heraion animals and are regarded as Argive by most scholars. They are centred round ARG 46 = Ol. Br. 1308, Heilmeyer 1979, no. 147, pl. 21. Heilmeyer, 64, discusses the group and its characteristics, underlining the interest in surface finishing and detail rendering, criteria which do not apply to the Argive Heraion horses. Although I see some stylistic similarity I am not convinced of the attributions.

NOTE 185

Kilian - Dirlmeier 1985, 230 - 231, fig. 13, concludes that 32,8 % of all outside Geometric/ early 7th Cent. BC votives in Olympia are Argive (as compared with e.g. 0.5 % of Arcadian votives). Except for the limited group of Tripods with Fanned Grooves, she considers all cast Geometric tripods at Olympia as Argive and she strictly follows Heilmeyer's attributions of the Olympia bronze statuettes. In general, the certain Argive Geometric bronzes are rare at Olympia, cf. also notes 277 and 289 below, for the absence in this sanctuary some Northeast Peloponnesian pin types which were produced only or partly in Argos or the Argive Heraion.

NOTE 186

A publication of the Argive Heraion Geometric terracottas and vases would expand the comparative material as will, of course, excavations at other Argive sites, cf. note 193 below. However, archaeologists such as

H. Sarian and F. Croissant have contributed decisively with their studies based on early Argive terracottas and vase-painting, cf. pp. 61 - 62 and note 189 and 193 below.

NOTE 187

Argos Mus. B 75. Courbin 1955, p. 314. Gehrig 1964, 49. Zimmermann, ARG 94, pp. 25 and 43 and pl. 7. Apart from its incrustation, it is also slightly damaged and there are scratches on the legs.

NOTE 188

It is difficult to find comparative material from Argos itself; e.g. the fragment of a terracotta horse from the Geometric terracotta groups mentioned in note 190 below, is too small to give any useful information, cf. Sarian 1969, 656, nos. 10 - 11, fig. 26. The nearest parallel to the decoration of the base plate is seen on Zimmermann, ARG 119, pl.73; but the two diagonal motives are not identical.

NOTE 189

Delphi. Inv. No. 3649. Rolley 1969, no. 28, pp. 45 - 46, pl. IX (H. 12 cm); Sarian 1969, 661 - 664, figs. 14 - 16; (The Geometric terracotta groups from Argos, cf. BCH 1967, 844 and Sarian, op. cit. nos. 1 - 6, figs. 1 - 11, pls. XV - XVI; (only no. 1 has the head preserved). For their chronology, cf. their LG context BCH 1967, p. 844). Cf. Foley 1988, 102 - 103 and Croissant 1992, 78 - 79, pl. 27, figs. 23 and 25. (The terracotta warriors, pl. 27, figs. 22, 24 and 32).

NOTE 190

Cf. Sarian 1969, 661 and Rolley 1969, 46 with note 4, pp. 26 and 30.

NOTE 191

Heilmeyer 1981, 68 - 71, considers the figure groups Laconian based on the criteria for the Laconian Geometric horses. According to Felsch 1983, 26 - 27 and fig. 12 these bronze groups may be dated before 750 BC judging from the chronology of a seated male figure in Kalapodi. This date cannot, however, apply to the Argive bronze figure from Delphi, the terracotta counterparts of which are Late Geometric, cf. note 189 above.

NOTE 192

Among the published early terracotta figurines at the Argive Heraion are riding warriors, but there are no chariots and figures which can be connected to a theme corresponding with that of the terracotta groups from Argos.

Although the engraved decoration of the bronze horses from the Argive Heraion, cf. Fig. 19 and note 159 above, appears to illustrate the harness of chariot horses, the statuettes were offered as separate figures, and do not form a part of chariot groups.

NOTE 193

For LG bronze statuettes at other sites in the Argolid, cf. a horse from Nemea, Br 20. Zimmermann, ARG 127, p. 237 and pl. 10, and Miller 1990, 51 - 52 and fig. 16, and a woman's figure from Asine, Protonotariou - Deilaki 1961, 318 - 319, cf. Langdon 1984, 178, C 138; Floren 1987, 51 and 72 and Foley 1988, 90 and pl. 18 d. The Nemea horse is without exact parallels and is presumably a local product, whereas the Asine statuette may be Cretan. For Early 7th Cent. bronze statuettes at the Argive Heraion, cf. AH 17 - 18, p. 58 and note 169 above, and at Argos Croissant 1992, who also, 72, cf. pl. 22, figs. 1 - 2, stresses the stylistic continuity of the figure style of Argos, by pointing out - as earlier noted by other scholars - the similarity in the thorax renderings of the LG cuirass from Argos and the statue of Cleobis.

NOTE 194

There are 16 bronze bird figures from the Argive Heraion: AH 36 - 48 and AH 881, NM 16562 and 16971. AH 44 comes from the "Upper Hill", cf. IS I, 192, note 136; NM 16971 from the Altar site, cf. IS I, 176, note 33; a cock pendant, either AH 47 or AH 48, from the foundations of the Second Temple and AH 37 and 39 from around the Northeast Stoa, both buildings situated close to the Altar area, cf. p. 38. and notes 18 and 17 above, respectively. AH 46 or AH 48 was found in the western fill, cf. IS I, App. 201 and AH 36 in the West Building, cf. note 21 above, i.e. presumably originally from altar fills, cf. p. 38 above. Finally NM 16554 comes from the Southern Slope, cf. note 24 above.

NOTE 195

Bouzek 1967, and Bouzek 1971. For later studies, cf. esp.: K.-D. Anhänger; Kilian 1975 a; Sapouna - Sakellarakis 1978; Rolley 1969, esp. 84 - 93; Rolley 1977, esp. 7; Heilmeyer 1979, 185 - 190; Philipp 1981, 362 - 366, nos. 1282 - 89, pls. 24 and 79 - 80; Foley 1988 esp. 92 - 93; Voyatzis 1990, esp. p. 147 - 157. For criticism of Bouzek's regional attributions, cf. esp. Rolley 1969, 90 - 92 and notes 198 and 203 below.

NOTE 196

I have handled only a few of the figures and most measurements are taken from AH and the other relevant publications.

NOTE 197

AH 881 (NM 14033), AH II, 244, pl. LXXXVII.

H. 4.8 cm, W. 2.8 cm. The fastening pin is missing but had once been reinserted.

Blinkenberg, 146, No. VII 14 c; Bouzek 1967, 122 and fig. 4, 13; Kilian 1975 a, 135;

Sapouna - Sakellarakis 1978, 99, with note 7 (Type VII b);

Philipp 1981, 271, note 258, cf. note 250 below;

Foley 1988, 84.

The heads of both birds are missing as well as the tip of the tail of the bird on the plate. The plate is very worn, but there are traces of a horizontal tremolo line, ca. 0.3 cm. above the lower rim. The vertical catch has a trapezoid section and there are two profiled rings above, four below.

Bouzek 1967, 122, note 22, notes that on genuinely island fibulae, the bird is never placed on top of the plate, only on the bow (cf. Sapouna - Sakellarakis 1978, 97 - 99, Type VII b, pls. 38 - 40) to which observation, however, there is one exception, Sapouna - Sakellarakis, no. 1444, pl. 40, from Ialysos. The fibulae of a hoard in the Archaeological Museum of Istanbul, said to have been found near Smyrna, op. cit. 99, note 7, do not have this trait. For the Lusoi fibula, cf. Mitsopoulos - Leon 1990, 35 - 36, fig. 6, of the type Blinkenberg VIII 8. Bouzek attributes the birds of AH 881 to his Argive type.

NOTE 198

Bouzek 1967, 119 - 121 and fig. 2.

For the distribution area, cf. K.-D.

Anhänger, pl. 104 B (birds on vertically placed disks) and pl. 105 A (birds on prism formed stamps). Cf. op. cit. 157 - 158 and 167 for a Central Greek origin. Cf. also Felsch 1983, 128, and Felsch 1980, 57 - 58 who states that with one exception all of the 20 Geometric birds found at Kalapodi are of Bouzek's Corinthian type and, with two exceptions, both from Delphi, Bouzek's Central Greek type is not represented in Central Greece at all.

NOTE 199

AH 39 (NM 13960), AH II, 205, pl. LXXVI.

H. 3.6 cm, L of base 2.8 cm.

For a corresponding fastening plate with an upper undulating plate from Tegea, cf. Du-

gas 1921, 349, no. 22, fig. 9, and for two birds on such a plate, decorating the top of a conical pendant from Philia, cf. Christiansen 1993, 74 - 75 no. 44. As the holes of AH 39 are in the plate not through the birds, they cannot have been meant for suspension.

NOTE 200

AH 40 (NM 13953) and AH 41 (NM 13955), AH II, 205, and pl. LXXVI.

AH 40, H. 3.5 cm. AH 41, H. 3.2 cm.

Bouzek 1967, 119 and fig. 2, 10 - 11.

AH 40 = K.-D. Anhänger, no. 974; Rolley 1969, 84 and Philipp 1981, 365.

AH 41 = K.-D. Anhänger, no. 913.

Loc. cit., Kilian Dirlmeier placed the latter bird among the birds on vertical disks, a type which otherwise is not represented at the Argive Heraion. The bird is badly preserved and broken just below the stem, with no trace of a disk. I find it difficult to determine its exact type, but on the whole I find a prism pendant more likely than a disk pendant.

For the parallels in Kalapodi, cf. Felsch 1983, 127 - 128, figs 14 - 16, and esp.

Felsch 1980, 56 - 57, figs. 26 - 28. Esp.

close to AH 40 is the prism pendant, B 602, op. cit. p. 52 and fig. 28. For its absolute chronology, cf. note 214 below.

NOTE 201

AH 2837 (NM 20831/2), AH II, 331 and pl. CXXXVI. H. 4 cm.

NOTE 202

NM 16562, Blegen 1939, 438 and fig. 25.

According to Blegen the object measures 12 cm. in total length and 6.5 cm. in total height; the birds measure 2.5 cm. in length and 1.9 cm. in height. One of the stems of the vertical element is bent; in their ring profiles they resemble the stems of the Thessalian - Central Greek arm rings, cf. pp. 69 - 70 and note 235 below, AH 1597 - 1599 (Fig. 34).

Compare with K.-D. Anhänger, 184, nos. 1112 - 1112 A, pl. 58. The former object comes from Anavra in Locris, the latter is of unknown provenance in a private collection. The birds on a third stand, no. 1113 from Sparta, are of a different type.

NOTE 203

AH 38, AH II, 204 and pl. LXXVI.

The base plate is broken off and the bird is badly preserved to a height of 3.6 cm.

Bouzek 1967, 121 and fig. 3.3. (Argive).

For the type of bird, cf. Kilian 1975 a, pl. 83, 18 - 20 and pl. 84, 1 - 19 from Pherai and K.-D. Anhänger, 171 - 175 nos. 1015

- 1051, pls. 54 - 56, chiefly from Pherai, (Conclusion: Thessalian, 175) and Christiansen 1993, 66 - 69 nos. 34 - 36, Philia.

NOTE 204

AH 42 (NM 13956), AH II, 205, pl. LXXXVII.

Bouzek 1967, 121 and fig. 3, 4 (Argive). K.-D. Anhänger, no. 1019, p. 172 and pl.

55, cf. note 203 above.

Heilmeyer 1979, 187, compares this bird as well as AH 43 and NM 16971 with his no. 942 (= K.-D. Anhänger no. 952 and Philipp 1981, no. 1283). In my opinion, his observations are valid only for AH 43 and, as to its stem, for NM 16971, cf. notes 206 - 207 below. Both Heilmeyer, loc. cit., and Foley 1988, 93 and note 124, seem to regard the Argive Heraion birds as local. Considering the types of base plates of bronze quadrupeds from the Argive Heraion, locally produced pierced base plates such as those of AH 42 - 43 do not appear likely to me, cf. pp. 54 - 56 above.

NOTE 205

AH 44 (NM 13947), AH II, 205, pl. LXXXVII.

H. 1.9 cm, L. 4.5 cm. Inside partly filled with some dark substance, probably the clay core.

It is related to K.-D. Anhänger, nos. 775 - 777, Thessalian birds, cf. p. 140 - 141, pl 43.

NOTE 206

NM 16971, Blegen 1939, 433, fig. 18. H. 4.3 cm.

Heilmeyer 1979, 187, cf. note 204 above.

For the bird type, cf. AO, pl. LXXVI, g, h and n, and Bouzek 1967, 116, fig. 1, 1 - 3. For the stamp pendants from Tegea, cf. K.-D. Anhänger, nos. 171, 183 and 241 = Voyatzis 1990, B 68, 75 and 109.

For Laconian influence on Arcadian bronze statuettes, cf. p. 58 and note 173 above and Voyatzis 1990, 150 - 152.

NOTE 207

AH 43 (NM 13961), AH II, 208, pl. LXXXVII.

K.-D. Anhänger, no. 1081, p. 178 and pl. 57. Bouzek 1967, 121 and fig. 3.7 (Argive).

Heilmeyer 1979, 187 (Argive, cf. note 204 above).

Foley 1988, 93 and note 124.

Voyatzis 1990, 56, accepts the suggestion, Sinn 1980, 30, of a Lusoi production centre, because of the base plate of her no. L 17, pl. 90. Her no. L 16, pl. 91, is related to Heilmeyer 1979, no. 942, cf. note 204 above.

AH 43 is definitely related to this group, cf.

K.-D. Anhänger, 161 - 164, nos. 952 - 954 and 956. Just as for AH 42, I find an Argive production unlikely, cf. note 204 above.

NOTE 208

AH 36 - 37 (NM 13958 - 59). AH II, 204 and pl. LXXVI.

AH 36, H. 5.25 cm.; AH 37, H. 3.7 cm. Bouzek 1967, 120 and fig. 3, 1 - 2 (Argive) AH 36 = K.-D. Anhänger, no. 961, p. 162 and pl. 52. Cf. Philipp 1981, 364 and note 689.

For AH 37 cf. K.-D. Anhänger, 162 and note 104.

NOTE 209

Bouzek loc.cit.

Cf. Voyatzis 1990, B 51 and B 53, pp. 152 - 153, pls. 87 and 88: For the relief decoration of the base of the latter bird, cf. note 149 above. However, I see no relation to Dugas 1921, no. 33, p. 351 and fig. 6, to which Voyatzis also refers.

I do not understand the comparison, Rolley 1969, 85, of AH 36 - 37 with the Delphi birds, his Nos. 135 - 136, pl. XXII; both are small, compact Thessalian birds of the same type as AH 38, cf. p. 64 and note 203 above; cf. also Voyatzis 1990, 152-153. A better comparison might be Rolley, loc. cit., no. 140, which may have the same origin as AH 36 - 37.

There are also Laconian or Laconian influenced Peloponnesian birds with a flat underside; in some cases they have pierced base plates, cf. Heilmeyer 1979, 186 - 187, nos. 931 - 937; Droop 1907, 111, Fig. 2 b from the Artemis Orthia Sanctuary, K.-D. Anhänger, no. 963, p. 162 and pl. 52, from Lusoi and Voyatzis 1990, 155 - 156, nos. L 15 - 16, pl. 91. The Lusoi examples may be local.

NOTE 210

AH 45. AH II, 205 and pl. LXXVII.

H. 1.4 cm. It is badly preserved but very similar to AH 46.

AH 46 (NM 13979). AH II, 205 - 206, pl. LXXVII.

H. 2.3 cm.

Bouzek 1967, 127 and fig. 10, 2.

K.-D. Anhänger, 149, no. 843 and pl. 47.

AH 47. (NM 13952). AH II, 206 and pl. LXXVII.

H. 5.5 cm.

Bouzek 1967, 127 and fig. 10, 1.

K.-D. Anhänger, no. 712, pp. 128 and 131 and pl. 37.

Foley 1988, fig. 10.

Voyatzis 1990, 148 and note 274.

AH 48. (NM 13954). AH II, 206, pl. LXXVII.

H. 4.45 cm.

Bouzek 1967, 129 and fig. 10, 3.

K.-D. Anhänger, 132, no. 726 and pl. 39.

Foley 1988, fig. 10.

NOTE 211

Cf. Bouzek 1967, 125 - 133.

For the Thessalian type, cf. K.-D. Anhänger, 149 - 150, nos. 840 - 847, pls. 47 - 48, and for the Arcadian type, esp. op. cit. pp. 128 - 129, nos. 712 - 719, 37.

Rolley 1969, 88 and 90.

For AH 46, cf. in particular, K.-D.

Anhänger, No. 842 = Christiansen, p. 77, No. 50, from Philia. Another close parallel, although with horizontally bored hole, comes from Lusoi, Mitsopoulos - Leon - 1990, 35 - 36, fig. 5, possibly a sign that these cock types were also locally manufactured in Arcadia.

AH 47 belongs with the group, Voyatzis 1990, B 38 - 42, p. 148 and pls. 83 - 84, and AH 48 is close to this type, but a variant, the relief lines bordering the neck having been replaced by incised lines, cf. Voyatzis, B 42, p. 148 and pl. 85. They all belong to Kilian-Dirlmeier and Voyatzis, Variant I, presumably of Tegean manufacture, cf. K.-D. Anhänger, 129, and Voyatzis 1990, 148 - 149 for conclusions.

NOTE 212

For bird pendants used together with a necklace as the breast ornament of a dead woman, cf. the Amphikleia tomb (note 214 below). For other used and repaired personal ornaments at the Argive Heraion, cf. note 30 above.

NOTE 213

The birds which later were specifically connected with Hera such as the cuckoo, the peacock and the crane, cf. Bevan 1986, 35 - 39, are not among the Geometric bird figures at the Argive Heraion, nor are water birds which Bevan, 38, suggests may be reflected in the later association with the crane. For the quadrupeds, cf. p. 58 and note 170 above.

NOTE 214

Cf. note 167 above for the chronology of the bronze quadrupeds. The stratigraphical evidence from the Artemis Orthia Sanctuary applies also to the bird figures.

Delphi.

The two bronze birds, Rolley 1969, nos. 145 - 146, pp. 86 and 88 - 89, pl. XXIII, were found in LG contexts, cf. Lerat 1938, 217 - 218.

Kalapodi.

Several Geometric bronze birds of Central

Greek type came from stratigraphical contexts. In and immediately above an ash layer, presumably from an altar, were found two bird figures. The ash layer was dated to the second half of the eighth Cent. BC from a local skyphos fragment, imitating Attic LG I pottery, which was found immediately below the layer. In an overlying clay layer, containing also an EPC kotyle fragment and thus datable to the late 8th Cent. BC, were two more bird figures, including the prism pendant B 602, cf. note 200 above. (Felsch 1980, 50 - 52)

On the second pavement of the altar in the Temple lay several fibulae (cf. note 247 below). Through the pavement and its overlying fill two bothroi which contained several Boiotian plate fibulae of iron were dug at the same time. In one of the bothroi were found two Central Greek birds together with fragments of an LG Thapsos bowl and immediately above the bothros lay two more bronze birds. The bothroi and the fill above were covered by a pavement dated to the late 8th Cent. BC by an EPC fragment. Above this pavement was another fill with a local imitation of a Thessalian plate fibula. (Felsch 1983, 124 - 127; the birds, figs. 14 - 16, cf. Felsch 1987, 11 - 12).

The following grave contexts are relevant:

Amphikleia.

Unpublished female burial with very rich grave goods of bronze, including a necklace with three birds, seven birds on disks and three Boiotian plate fibulae with incised decoration of fish, birds and centaurs. BCH 1954, 132; and JHS 1954, 157 - 158; Cf. K.-D. Anhänger, esp. p. 17, no. 73 and p. 18. On exhibition in Athens NM, Room 37.

The grave goods do not contain datable pottery, but the bronzes are, in general, not earlier than late MG, cf. in particular, the plate fibulae, p. 75 and note 254 below. The birds are K.-D. Anhänger, Nos. 978 and 989; the last-mentioned bird is placed on a four-legged base, cf. note 216 below, the others are chiefly Central Greek birds on vertical disks or prisms.

Tiryns. Tomb 30.

Tiryns I, p. 132, Fig. 6. Photo of underside of base plate. (The bird, H. 3 cm. is compared to the bird from Artemis Orthia, BSA XIII, p. 111, Fig. 2 b, cf. note 209 above).

K.-D. Anhänger, 166, note 122 (LG).

Foley 1988, 93 (MG II).

The tomb Tiryns I, 132, contained two bronze and two iron finger rings as well as pottery, pl. XVII, 2, 3, 7 and 9 and pl. XVIII, 2, 5 and 9. According to Cold-

stream 1968, 120, the tomb is MG II. However, it is a child's burial and all the vases are miniatures which may just as well be dated in LG. Foley, loc. cit., follows Coldstream's chronology of the tomb, although she, p. 65 and pl. 9 d, illustrates one of the vases as a representative of LG. I follow Kilian -Dirlemeier in an LG date and also find that the figure relief of the underside of the base plate is rather advanced for an MG date.

NOTE 215

The two Geometric bronze birds from Perachora are presumably Macedonian or Thesalian imports, cf. Perachora I, pl. 37, 1 and 3 = K.-D. Anhängers, no. 720, pp. 129 - 130, pl. 37 and no. 789, pp. 141 - 142, pl. 44. I do not know of Geometric bronze birds from other Corinthian sanctuaries as e.g. Corinth and Isthmia.

NOTE 216

K.-D. Anhängers, no. 988 A, p. 168 and pl. 54, cf. ADelt. 16 B, 1960, p. 93, no. 4, Tomb 5.

The group is collected by I. Kilian-Dirlemeier, op. cit. nos. 986 - 989, the last being the Amphikleia bird, cf. note 214 above.

Christiansen 1993, no. 51, p. 78, ill. p. 80, a pendant with three legs in the form of bird's heads from Philia, is reminiscent of this type of base.

NOTE 217

Apart from the Argos bird figure in note 216 and the lost Tiryns bird note 214 above, only K.-D. Anhängers no. 724, in the Metropolitan Museum is, as far as I know, said to have come from the Argolid; no. 724 has no certain provenance.

NOTE 218

Cf. esp. Philipp 1981, 19 - 20; Kilian 1975 a, 166; Kilian 1975 b, esp. pp. 105 - 106; Kilian (-Dirlemeier) 1978, 219; and Linders 1972, 69 - 70. For both types of offerings, cf. Felsch 1980, 56, note 66 and Felsch 1983, 124 (Kalapodi).

NOTE 219

Cf. e.g. note 30 above, AH 47, AH 87, AH 877 and AH 881.

NOTE 220

Of special importance for my studies are the following volumes of PBF: XI, 2; XIII, 8; XIV, 2 and XIV, 4 = K.-D. Anhängers; K.-D. Nadeln; Kilian 1975 a; and Sapouna -Sakellarakis 1978.

Other studies of special importance are Philipp 1981; Courbin 1974, 129 - 141; and Foley 1988, 80 - 86.

In some cases, I shall just refer to these earlier studies, in other cases where necessary, because they do not distinguish the finds of the Argive Heraion from those of Argos, I shall examine the objects in detail.

NOTE 221

Cf. p. 62 and note 194 above for the bird pendants and their find spots and notes 222 and 224 below for various pendants from the Southern Slope. Apparently only AH 1551 has a different find spot, cf. note 225 below.

NOTE 222

NM 16561. **Miniature axe.** Blegen 1939, 438 and fig. 25, no. 8. Here Fig. 27.

K.-D. Anhängers, 247, no. 1594, pl. 93.

Type B = nos. 1588 - 1595.

Wheel ornament. Blegen 1939, 438 and fig. 26.

K.-D. Anhängers, 17 - 18, no. 74 and pl. 5., Both ornaments were found on the Southern Slope, cf. Blegen, loc. cit.

I. Kilian - Dirlemeier regards all wheel ornaments as dress ornaments in disagreement with Furtwängler's theory of votive wheels. K.-D. Anhängers, loc. cit. reference to the Amphikleia tomb context, cf. note 214 above. For the context of wheel ornament and fibula from Kalapodi, cf. Felsch 1983, 126 and fig. 6; found in the LG bothros (cf. note 214 above).

Both ornament types are known from Geometric contexts, but continue, cf. K.-D. Anhängers, 253 - 254 and p. 18.

NOTE 223

Stamp pendants. AH 1557 - 1558 (NM 13987). AH II, 264, pl. XCII.

AH 1557 = H. 3.85 cm. and AH 1558 = H. 3.65 cm. = K.-D. Anhängers, no. 248, p. 39 and pl. 15 and No. 170, p. 33 and pl. 11. Cf. Voyatzis 1990, 178 - 179.

For AH 1557, Variant I, cf. Voyatzis, 183, from Tegea, B 106 - 112, 108 a and 119, 124 - 125, and from Lusoï, F 1997.

For AH 1558, Variant II, K.-D. Anhängers, 32 - 33, nos. 169 - 174, cf. Voyatzis, 178 - 179 and note 19; apart from the AH example seven come from Tegea and three from Lusoï.

Pomegranate pendant. AH 2763 (NM 20809 α). AH II, 327 and pl. CXXXIV.

L. 4.6 cm, Max. W. 1.9 cm. Hollow with open bottom, Diam. of hole 0.45 cm. Around bottom hole, circular disk with radiating grooves. Its closest parallel seems to be Voyatzis 1990, B 142, p. 184, pl. 113 =

K.-D. Anhängers, Type D I, no. 695, p. 125 and pl. 36.

Both stamp pendants and pomegranate pendants are most likely Tegean products, cf. Voyatzis, 186 - 187.

For discussion of the function of the stamp pendants cf. K.-D. Anhängers, 40 - 41 and for their distribution pattern, pl. 101. For their chronology, cf. also p. 68 and note 229 below.

NOTE 224

For Macedonian or Macedonian type bronzes at the Argive Heraion, cf., in particular, Bouzek 1974 b, 303, The Argive Heraion; Bouzek 1974 a, passim; Kilian 1975 b.

Pyxis pendant. AH 2019 (NM 20590), AH II, 286, pl. CXVII.

Diam. 3.95 cm. (Found on Southern Slope) = K.-D. Anhängers, 234, no. 1508, pl. 84. (op. cit. p. 236, dated to the Period Mac. II A. For Mac. II A, cf. Kilian, op. cit., 104 - 105 and pl. 102 = Early 7th Cent. BC; Kilian, op. cit. 113 and note 1151, pl. 194, Type 3.). Bouzek 1974 a, 28, Cat. no. A 2, 6, fig. 6, 5. (Early Group), cf. Bouzek 1974 b, 307 and 332.

Bell pendant. AH 1556 (NM 20672γ), AH II, 264 and pl. XCII. H. 5.25 cm. (Found on Southern Slope). Bouzek, op. cit. 87 - 91, no. C 2, 1 = fig. 26, 2, cf. Bouzek 1974 b, 309. Date ca. 650 - early 6th Cent. BC.

Beads. AH 1548, 1549 and 1550 (NM 13993), AH II, 264 and pl. XCII. The measurements are L. 5.1 cm. and Diam. 2 cm.; L. 6.1 cm. and Diam. 3.25 cm. and L. 6.6 cm. and Diam. 3.55 cm., respectively. AH 1550 is damaged. Macedonian, cf. Bouzek 1974 a, 112. Group F, no. 21, fig. 34: 3, 7 and 10, cf. Bouzek 1974 b, 311. Date Late 8th - Early 7th Cent. BC. AH 1552, AH II, 264 and pl. XCII. Bouzek, op. cit. p. 106, Group C, no. 23.

NOTE 225

Both: AH II, 264 and pl. XCII. AH 1547 (NM 13997), L. 4 cm. Diam. 1.65 cm. Bouzek 1974 a, 119 - 121, Group L, 4, fig. 37, 2. AH 1551 (NM 13995 α) L. 2.45 cm, Diam. 2.2 cm. Found behind Stoa (not certain which stoa). Bouzek, op. cit. p. 118. J I, 2, fig. 3, 10. Both Greek imitations.

NOTE 226

For the absolute chronology of the Macedonian beads, cf. Bouzek 1974 a, 107, Group F Late 8th - early 7th Cent. BC., for the Greek imitations, cf. Bouzek 1974

a, 119 (Group J), probably 7th Cent. BC, and 119 - 121 (Group L), late 7th Cent. BC.

NOTE 227

Blegen 1937, 382.

NOTE 228

Argos.

Axe pendant. Larissa. The Athena Sanctuary, B 76. K.-D. Anhängen, 248, no. 1597, pl. 93.

For the type, cf. op.cit. pp. 248 - 254 and Voyatzis 1990, 194 -195.

Another double axe in bone is mentioned by A. Roes, BCH 1953, 94, note 2. For a simple miniature axe in iron, cf. note 328 below.

NOTE 229

Argos.

Ring pendants. Larissa. The Athena Sanctuary. B 80. = K.-D. Anhängen, 12, no. 35, pl. 2. L. 4.4 cm. Cf. Voyatzis 1990, 187 - 188, B 148, pl. 115. She considers the Argos example a Tegean import.

The Aphrodision, 70/1553. Diam. of ring (without knobs) 2.5 cm, Th. of ring 0.4 cm, Diam. of knobs 0.3 cm. Flat underside, rounded top; about half preserved. Although the eye is not preserved, I consider it a pendant not a ring because of its flat underside. Cf. K.-D. Anhängen, p. 12, no. 38, pl. 3, however with an oval section. From Pherai. An example in lead comes from the so-called Hera Limenia deposit, Perachora. Perachora I, p. 187, and pl. 85, 29.

Philipp 1981, 189 and pl. 144 from Olympia is considered a ring; loc. cit. ref. to a similar unpublished ring from Delphi.

Stamp pendants.

The pyramidal stamp from the Aphrodision, 69/592 bis, L. 3. 8 cm, is close to Voyatzis, B 113, p. 183, pl. 107 = K.-D. Anhängen, no. 264, p. 39 and pl. 16, but without the circular ornamentation of this stamp.

NOTE 230

The Aphrodision was founded at the end of the 7th Cent. BC, cf. ref. IS I, 199 and note 173.

NOTE 231

The apparent correspondence in form between a local, hand-made ceramic pyxis from a LG tomb at Argos, Argos C 2437, and Macedonian pyxis pendants may be fortuitous, since the Argive vase continues an earlier tradition of hand-made pointed pyxides known also from Attica. ADelt. 17

(1961 - 62), pl. 57 B; Courbin 1966, 245 - 246 and pl. 99; Courbin 1974, 75 -78 and pl. 48 (From Tomb 176/2, LG). Cf. K.-D. Anhängen, 236 and pl. 110; Reber 1991, 125, note 25. Reber refrains from studying the Argive pyxides because of lack of published examples.

NOTE 232

Earrings

AH 1553 (NM 20672 γ), L 2 cm., and AH 1554 (NM 20672 β), L 3 cm., Diam. of disks, 0.9 cm. AH II, 264 and pl., XCII. For AH 1554, cf. IS I, 176, note 33.

NOTE 233

Cf. Philipp 1991, 112 - 116, nos. 398 - 399, for counterparts to AH 1553 and no. 394 for one of the type of AH 1554, although with conical disks. For AH 1553, cf. esp. Lindos I, 114 - 119, nos. 271 - 274, pl. 12. List of provenances, p. 115 (Chr. Blinkenberg). Blinkenberg, loc. cit. suggests a Cypriot origin. Higgins 1980, 102 - 103 suggests a Syrian origin. Cf. also Kilian 1975 a, pl. 70, 2 - 9 (Pherai). For AH 1554, op. cit. 103 with reference to Perachora (Perachora I, 74 - 75, pl. 18, 4 and pl. 84, 26 - 29) and to Geometric tomb finds from Corinth. Philipp 1981, loc. cit. refers to the terracotta earrings, AH II, 43, no. Tc 281, fig. 88. There are 22 fragments of such disks, some solid painted; the illustrated, complete example has flat disks with painted cross decoration. The terracotta earrings from Tiryns, some also with cross decoration, have conical disks (Tiryns I, 85, no. 157). Although apparently particularly connected with the Northeast Peloponnese, the type with flat disks is also known in East Greece, cf. Blinkenberg, loc. cit. no. 275.

NOTE 234

Arm Rings.

AH 971, AH II, 251, pl. LXXXIX. Diam. 6.4 cm. According to Philipp 1981, 197, note 392, there are dated examples of plain arm rings as early as PG and EG. AH 1359, AH II, 258 and pl. XC. Diam. 5.9 cm.

AH 1361 - 62, AH II, loc. cit. Diam. 8 cm. and 7.1 cm., respectively. Cf. Philipp 1981, 196 -199, nos. 721 - 730 and 731 and 740.

The Thessalian - Macedonian rhombic arm ring, Blegen 1939, 442 and fig. 29, above left, here fig. 33 (Diam. 8.5 - 9.1 cm.); Philipp 1981, 199 with note 393. For the type cf. Kilian 1975 a, pl. 66, nos. 25 - 31 and pl. 67 and Kilian 1975 b, 109 and 131, pl. 86.3 and Philipp 1981, 199 - 200.

The type is known also from Anavra, Delphi, Dodone, Olympia, Perachora, Pherai, Philia and Vergina.

NOTE 235

Arm Rings.

AH 816 and possibly 815, AH II, p. 240 and pl. LXXXIV, cf. Kilian 1975 a, 173 with note 8, and Philipp 1981, nos. 810 - 812, pp. 219 - 220 and pls. 13 and 51. AH 1597 - 99 (NM 20531 α, β+γ), AH II, 266 - 267 and pl. XCIX. Cf. Philipp 1981, 205, also for general information and discussion of the Boeotian arm rings which are rare in the Peloponnese. Among the bronzes in Tragana, pithos π 9, there are some examples of Boiotian arm rings, cf. Onasoglou 1989, 20, nos. 35 - 38 and 41 - 42 and pls. 18 - 19. Tragana pithos π 9 is dated to ca. 750, cf. below note 247. According to Philipp loc. cit. the Boeotian arm rings are dated until ca. 650 BC. AH 972 and 972 a (NM 20914), AH II, 251 and pl. LXXXIX, Diam. 8 cm. and 4.2 cm., respectively. (The latter arm ring comes from the Back of the South Stoa). For the types, cf. Philipp 1981, 208 - 215, nos. 768 - 797. (For AH 973 and 974 (NM 20916) cf. note 12 above).

NOTE 236

Finger rings.

Cf. Verdels 1963, 7 with note 5 and fig. 3; Courbin 1974, 118 - 119, 132 - 133; Foley 1988, 85 - 86 and Philipp 1981, 138 - 152. The plain finger rings, AH II, 250 - 262, pls. LXXXVIII - XCI. Cf. Philipp 1981, 138 - 142 and references note 335. The angular finger rings, AH II, 258 - 259, pls XC - XCI, cf. Philipp 1981, 142 - 145. AH 1509 (NM 20671), AH II, 262, pl. XCI, cf. Philipp 1981, 146 - 148, nos. 538 - 541, pls. 7 and 42.

Band finger rings, AH II, 261 - 262 and pl. XCI, cf. Foley 1988, 85.

Tracy 1986, 196, pl. VIII. (Malibu. The J. Paul Getty Museum. 85. AM 264). Its dedicatory inscription to Hera, which was inscribed after the ring had been worn for some time, is dated to between 600 and 550 BC. The ring is said to have been bought at Mycenae and it is suggested that it came from the Argive Heraion. Cf. Johnston 1990, 444, no. A.

For the chronology of tremolo decoration, cf. Jacobsthal 1956, Appendix III, pp. 209 - 212, and for the instrument used, a scoper, and for the tremolo technique, p. 211, with ref. to AJA 1949, pp. 416 - 417 and fig. 20,

NOTE 237

Blegen 1939, 414 and fig. 4. = Here, Fig. 35. The ear ring second from left below and the arm rings above right.
Blegen 1937, 380 and Fig. 2 = Here Fig. 36.

NOTE 238

As the hair spiral rings known from the Argos tombs, but not from sanctuaries, are PG or EG, at the latest, they are not included in this study, cf. Courbin 1974, p. 119 and 133 and Higgins, 102.

The Northeast Peloponnesian earrings with cross-ornamented disks were apparently not found in Argos.

For the finger rings of Argos, cf. references, esp. to Courbin and Foley, above note 236.

The band finger rings in the Geometric Argos tombs are of two main types, one flat and one with a central ridge; they mostly come from 8th Cent. BC tombs, but also in a varied form from earlier tombs.

Different kinds of gold rings are found in EG tombs and are rare after ca. 850 BC, cf. Foley 1988, 95.

NOTE 239

Blinkenberg; Schweitzer 1969, 215 - 230; Kilian 1975 a; Sapouna-Sakellarakis 1978; Courbin 1974, 132; Philipp 1981, esp. 260 - 304; Foley 1988, esp. 84 - 85, studies the fibulae from the Argolid, especially the grave finds, many of which are earlier than the 8th Cent. BC. However, her observations on the Argive Heraion material are not very detailed and she is apparently not acquainted with the unpublished fibulae in the sanctuaries of Argos.

NOTE 240

For the number of fibulae (compared with that of pins) from the Argive Heraion, cf. Kilian 1975 a, 168 - 169.

From the West Building (cf. note 21 above) come the following fibulae: AH 820 - 821, 823, 829, 865, 877, 897, 905, 922, 928 and 948.

From either the Southern Slope or the Back of South Stoa (cf. notes 23 - 24 above), come AH 817, 826, 838, 855, 875, 876, 890, 907, 915, 924, 926, 939, 941 and 944 - 946 as well as Blegen 1939, 440, figs. 23 and 27 - 28.

Two of the best preserved fibulae were found on the Upper Hill, the spectacle fibula, AH 818, and the plate fibula, AH 879 (Figs. 37 and 39), cf. IS I, 192, note 136. There may be a small fragment of a spectacle fibula from the Old Temple Terrace, AH 822, but it is too fragmentary for a certain identification. For the Altar Area,

cf. IS I, 176, note 33. In the area east of the Northeastern Stoa (cf. above note 17) were found the fibulae AH 887, 901, 925 and 937 and at the Eastern Retaining Wall was found one, Caskey - Amandry 1952, 182, no. 108, (M 49.76), pl. 46. A few were found west of the Second Temple: AH 834 and AH 880.

NOTE 241

Arched fibulae. AH 827 - 847, AH II, 241 - 242 and pl. LXXXV. Cf. the following notes.

NOTE 242

Cf. IS I, 174, note 17.

NOTE 243

AH 829 - 830 and 839, AH II, loc. cit. AH 830 = Blinkenberg, XI c, p. 195; several fibulae of this type come from Arcadia, cf. Blinkenberg, XI d - e, p. 196 from Tegea and Lusoi. For the Lusoi fibula, cf. Voyatzis 1990, L 46, p. 217, pl. 169.

AH 844 = Blinkenberg III 1 b, p. 79 and AH 845 = Blinkenberg III 3 e, p. 80, cf. Kilian 1975 a, 22, note 3, who calls the type "wohl protokorinthisch" and cf. Voyatzis 1990, 210 - 211 and 216 - 217 with reference to the AH examples, note 231.

NOTE 244

E.g. AH 827 - 828, cf. Sapouna-Sakellarakis, p. 117 - 118 with note 5; AH 834 - 835 (Blinkenberg, XI k - l, p. 203), AH 837 and 847 (for the last-mentioned one, cf. Kilian 1975 a, 101 and note 1, parallels in Pherai). Cf. Blegen 1939, 440 and fig. 23.

NOTE 245

AH 833 = Blinkenberg VI 3 e, pp. 113 - 114 and Kilian 1975 a, 29, note 5. Op. cit. pp. 26 - 29, 117 examples in all from Pherai. Date late 8th - 7th Cent. BC, known also from Philia, Perachora, Amyklaion and Lindos.

For AH 838 and 841, cf. Kilian 1975 a, 70 and note 2.

For AH 843, cf. IS I, 174, note 17.

NOTE 246

AH 919 - 934 (NM 20903 - 20906), AH II, 248 - 249, pl. LXXXVIII.

The example from Prosymna tomb VIII, cf. note 260 below, is dated from its context in LG/Early 7th Cent. BC.

The type continues into the Archaic period, cf. AH 935 - 944, many of which have stamped tongue pattern.

NOTE 247

Spectacle fibulae.

AH 818 (NM 14035), AH II, 240 and pl. LXXXV = Blinkenberg, XIV 2 l, p. 258. L. 2.5 cm. Cf. Kilian 1975 a, 145, note 8. Fragments of spiral fibulae, AH 817 a - b, 819 - 823 and possibly 824 (NM 20901), AH II, 240 - 241 and pls. LXXXIV - LXXXV.

Studies of spectacle fibulae:

Blinkenberg, type XIV, pp. 253 - 262; Alexander 1965; Andronikos 1969, 227 - 230; Kilian 1975 a, 142 - 150 and Kilian 1975 b, 107; Philipp 1981, 295 - 304; Voyatzis 1990, 213.

For the tomb contexts of the spectacle fibulae, cf. Kilian 1975 a, 145 and cf. also Vitsa, Tomb 46, fig. 109, pp. 133 - 135, pl. 211 b; Tomb 103, pp. 149 - 150, pl. 240, and Tomb 113, pp. 151 - 157, pls. 247 b - and 248 b, all tombs dated by Vokotopoulou to the 9th Cent. BC. Cf. K.-D. Anhänger, 229, who dates Tomb 113 to ca. 800 BC.

Tragana in Locris, a pithos burial of a young woman, π 9, Onasoglou 1989, esp. 14 - 21, 35 - 51 and 229, pls. 11 - 21. The pottery dates the burial to shortly before or around 750 BC (pp. 15 - 16, 37 - 38, figs. 7 - 8 and pl. 11). The bronze finds comprise two bronze phialai, of which one was a North Syrian import with a neo-Hittite inscription (nos. 58 - 59, p. 10, 21 and 47 - 51, figs. 14 - 15 and pls. 10 and 21); 12 arm rings, including Boiotian arm rings (cf. above note 235), 20 finger rings of different Geometric types; one necklace of 375 small bronze pearls; eight pins (nos. 48 - 55, pp. 21 and 43 - 44 and pl. 20) including examples of K.-D. Nadeln, Geometric I A (cf. p. 79 and note 274 below) and eight fibulae, of which two were spectacle fibulae (nos. 12 - 13, pp. 18 - 19 and 43 and pl. 17) and six were Boiotian plate fibulae (nos. 6 - 11, pp. 16 - 19 and 38 - 42, figs. 9 - 13 and pls. 12 - 17).

A spectacle fibula comes from the LG Amphikleia Tomb, cf. note 214 above.

For the Kalapodi find, cf. Felsch 1983, 124 - 126; the spectacle fibula was offered together with a pair of Boiotian plate fibulae of iron, loc. cit. fig. 5. which Felsch because of the form of its plate dates to shortly after 750 BC, cf. also note 214 above and note 254 below.

The spectacle fibulae at Artemis Orthia in Sparta were found in the same strata as the bronze statuettes, cf. note 167 above.

For the suggestion that AH 813 - 814 are fragments of double spectacle fibulae, cf. note 248 below.

For ivory or bone spectacle fibulae at the

Argive Heraion, cf. AH II, 353, nos. 32 - 35, pl. 140 = Blinkenberg, XV, 1 b, p. 265 and NM 14054 (Fragment) = Blinkenberg, p. 268, no. XV 5 c.
Cf. Philipp 1981, 298: the type which is particularly favoured in Perachora and Sparta lasts into the 6th Cent. BC.

NOTE 248

Violin type fibulae.

AH 813 - 814 (NM 14031), AH II, 240 and pl. LXXXIV and Caskey - Amandry 1952, 182, no. M 49.76, pl. 46, no. 108, and Blegen 1939, 440 and fig. 27, below centre. A disk has been attached to the pin. For the type and its distribution, cf. Sapouna - Sakellarakis 1978, 39 - 40, Typ I f, pl. 2. Besides from several islands, the fibula type is known also from Lusoi, cf. Voyatzis 1990, L 38, p. 279 and pl. 169 and Artemis Orthia, Sparta, AO, 198 and pls. 82 and 91. I see no evidence for connecting these fibulae, which certainly had a decorative top piece, with the double spectacle fibulae, as suggested by Kilian 1975 a, 145, note 8, or with spectacle fibulae of bone or ivory, as suggested by Philipp 1981, 295, note 504, since these types were fastened with either one or more than two rivets, cf. Philipp 1981, 297 and Cat. nos. 1087 and 1100.

NOTE 249

AH 836 = Blinkenberg, 82, no. III 7 a. For AH 881 cf. p. 62, Fig 25 and note 197 above.
AH 880 (NM 20888). Pres. L. 4.5 cm. W. 1.7 cm. AH II, 244 and pl. LXXXVI = Blinkenberg, VI, 15 d, p. 118. A variant is known from Chios, cf. Sapouna-Sakellarakis 1978, 97, but the AH example is apparently Thessalian, cf. Kilian 1975 a, 68. Chronology Late 8th - Early 7th Cent. BC.

NOTE 250

AH 869 - 870 (NM 14032 and 20895/2), AH II, 243 and pl. LXXXVI = Blinkenberg, IV, 10 k, p. 99, cf. Sapouna - Sakellarakis 1978, 90, note 4; for the type, cf. op. cit., Type V, pp. 85 - 90 and Kilian 1975 a, 137 - 139, pls. 56 - 57, nos. 1543 - 1560. Besides these references, cf. also Felsch 1983, 124 and figs. 3 - 4 and Felsch 1987, 12 and fig. 16 (Kalapodi).

NOTE 251

Thessalian plate fibulae.

AH 871 - 875 and 877 - 879 (AH 875 = NM 20889, AH 879 = NM 14033, the other fibula fragments = NM 14032). AH II, 243 - 244 and pl. LXXXVI. Blinkenberg, nos. VII, 6 - VII 9, 135 - 142. No. VII 6 e (AH 879), VII 7 c (AH

875 and ref. here. p. 137 to AH 871 - 872), VII 8 h (AH 877), VII 9 d (AH 878). The arch fragment AH 877 has traces of the reinsertion of a new pin. The only fully preserved fibula is AH 879; the others are fragments, mostly of the arch. It is impossible to decide whether the small fragment of a globe, AH 876, belongs here. Kilian 1975 a, 115 - 137 and pls. 48 - 55. For references to the above AH finds, cf. p. 116, note 3 (AH 872), p. 118, note 6 (AH 879), p. 120, note 1 (AH 875), p. 127, note 6 (AH 873), p. 128, note 3 (AH 878) and p. 133, note 2 (AH 877). For chronology, op. cit. passim and Philip 1981, 273 and cf. also the local imitation from Kalapodi, note 214 above.

Philipp 1981, 270 - 276, esp. pp. 272 - 273 with note 459, classifies AH 873 as Thessalian, and, note 458, the AH finds in general, AH 871 - 872, 874 - 875 and 877 - 879, as a possibly Peloponnesian variant, although she does not exclude a Central Greek origin and points to Phocis as an intermediary. A Peloponnesian production was advocated by Payne (Perachora I, 169), a Central Peloponnesian one by Schweitzer (Schweitzer 1969, 217) and an Arcadian production centre by Coldstream 1977, 157 and Voyatzis 1990, 211 - 212.

The decoration of AH 879 might perhaps be considered secondary and made at the request of the dedicator. However, the fibula is very well preserved and presumably not used before dedication and if its decoration were secondary, the fibula was originally undecorated for which feature I do not know of any parallels.

NOTE 252

Boiotian plate fibulae.

AH 858 - 868, AH II, 242 - 243 and pl. LXXXVI. Blinkenberg, VIII 8 g, p. 180 (AH 858) and 12 g, p. 184 (AH 864 - 865 and 867 - 868). DeVries 1974, 92 - 104, the Lerna fibula, pls. 15 - 16; Kilian 1979; Philipp 1981, 276 - 286; Herrmann 1982 a; Foley. 1988, 84; Voyatzis 1990, 215 - 216.

NOTE 253

Blegen 1939, 440 - 442 (with ref. to Hampe's observation) and figs. 27 - 28. Hampe 1936, no. 33, pl. 17; DeVries 1974, 103; Philipp 1981, 277 and 280, note 487
Cf. references in note 252 above.

NOTE 254

For the context of the Lerna fibula and its chronology, cf. DeVries 1974, 80 - 92. The earliest Boiotian plate fibulae are dated to MG II, cf. Felsch 1983, 124 - 125 with notes 16 - 17 with references to an MG II context in Corinth, North Cemetery, grave 17 (Corinth XIII, 1964, 24 - 26 and pl. 17 (the fibula, no. 17 - 8) and to the Chamilavrisi find from shortly after 750 BC, cf. note 167 above. Cf. also note 247 above for a Kalapodi find dated to shortly after 750 BC and for the Tragana fibulae dated to shortly before or around 750 BC.

NOTE 255

Cf. DeVries, 1974, esp. 102. Philipp 1981, 276 - 277 and 280, connects the fibulae from the Argive Heraion with a group including the Lerna fibula, but sets the Blegen fibula apart. Cf. loc. cit. note 487, for the Peloponnesian finds and Voyatzis 1990, 211 for the finds in Arcadia.

NOTE 256

For the suggestion of Argive production, Kilian 1979, 36 - 37; Philipp 1981, 277 and Foley 1988, 84.
For the Bonn horse cf. note 180 above and for the disk from Tegea, Voyatzis 1990, 214 - 216 with earlier references and fig. 128. Voyatzis, loc. cit., advocates an Arcadian production of the disk as well as of the Peloponnesian group of Attic-Boiotian fibulae. Also Herrmann 1982 a, 259, suggested an Arcadian or Central Peloponnesian production of the Peloponnesian fibulae. The engraved decoration of the Bonn horse differs from that of the horse AH 13, cf. above Fig. 19, pp. 56 - 57 and note 159, which imitates the harness of a chariot horse, but does not have engraved figure decoration or tremolo decoration. I find the engraved birds on the neck of the Bonn horse very close to those of the Peloponnesian examples of Boiotian fibulae and see an Arcadian origin as most likely.

NOTE 257

Cf. pp. 53 - 58 and notes 139 and notes 163 sqq. above for Arcadian Geometric bronze statuary and pp. 65 and 67 and notes 206 - 207 and 223 above for Arcadian bronze pendants.

NOTE 258

Blegen 1939, 412 - 413, fig. 4; Foley 1988, 84. Cf. Kilian 1975 a, 19 and note 14, and, for Olympia, cf. Philipp 1981, 264, nos. 993 - 995, pl. 59. A counterpart from the Hera Limenia deposit dates the type into the 7th Cent. BC.

NOTE 259

Blegen 1939, 414, fig. 4, cf. note 243 above, AH 844 -845.

NOTE 260

Tomb XXXVII, Blegen 1937, 379 and Prosymna, fig. 301, cf. note 248 above. Tomb IX, Blegen 1937, 379 - 380, fig. 2. Only the bow is preserved, 4.8 x 2 cm. Philipp 1981, 280, note 487. For the absolute chronology of the Prosymna tomb deposits, cf. p. 91 and note 362 below.

NOTE 261

Argos Museum. Vollgraff Br.1855. Simple arch fibula. L. 7. 7 cm. B 67 and B 68, the catch of the latter is not preserved. Cf. p. 72 and note 244 above, AH 844 - 845.

NOTE 262

Aphrodision, no. 72/1013, Simple arch fibula. Fragmentary. Preserved L. 5 cm.

NOTE 263

Argos Museum. Violin type fibula, B 88, fig. 43, cf. p. 73 and note 248 above. Spectacle fibulae, Vollgraff, Br.1855. Two fragmentary fibulae with part of the pin preserved in an "Acherschleife". Max. Diam. of spirals, 3.4 cm. and 2.9 cm., respectively. Cf. pp. 72 - 73 and note 247 above.

NOTE 264

Argos. Museum. Vollgraff, Br. 1854. It is not possible to see whether it had engraved decoration. L. 7.6 cm., Preserved H. of plate 5.6 cm., W. of plate 3 cm., Diam. of central globe 1. 7 cm., of side globes 1.3 cm. Cf. Blinkenberg, VII 8, esp. 8 a, b and h (the last-mentioned fibula = AH 877), pp. 139 - 140 and cf. pp. 73 - 74 and note 251 above. Vollgraff, Br. 1855. L. 3.5 cm., H. 2.8 cm., H. of plate 1.8 cm., Diam.of central globe 0. 7 cm. Cf. Blinkenberg IV 11 d = Thera II, p. 299 - 301, fig. 489 h - k (Schiff's Tomb, dated to LG/ Early 7th Cent. BC, cf. Sapouna- Sakellarakis 1978, 38, no. 19) and cf. Voyatzis 1990, 212, pl. 165, B 249 b - 250 with ref. to Kilian 1979, 37, fig. 9. 12, who mentions one more example of the type at Mavriki. Vollgraff, Br. 1854. Only the centre of the arch is preserved with two rings on one side and one on the other. Preserved L. 2.8 cm., H. of centre 1 cm. Cf. esp. Blinkenberg, 91 and fig. 92, IV 2 d from the Ida Cave, Crete, and Philipp 1981, nos. 1002 - 1003, p. 267 and pls. 18 and 60,

esp. the former fibula, with ref. to Blinkenberg IV 11 f and h for LG contexts, note 451, and for new finds in Chios, note 452, cf. Sapouna-Sakellarakis 1978, 54 - 68, Typ III.

With the number Vollgraff Br. 1855 is also a small fragment of a fibula bow (1.2 x 2.6 cm.) which possibly is a fragment of a tripartite bow of a Boiotian plate fibula.

NOTE 265

For fibulae in Geometric Argos tombs, in general, cf. Courbin 1974, 132 and Foley 1988, 84 (here also reference to other fibula finds at other sites in the Argolid). For Boiotian plate fibulae in the Argolid, cf. Philipp 1981, 280, note 487 and cf. end of note 264 above.

NOTE 266

K.-D. Nadeln.
The pioneer work is Jacobsthal 1956. Cf. also Courbin 1974, 130 - 131; Philipp 1981, 30 - 54; Rolley 1988, 345 - 347 (Review of K.-D. Nadeln) and Foley 1988, 80 - 84.

NOTE 267

Cf. K.-D. Nadeln, 77 - 78 and 80 - 83 (Submycenaean/Protogeometric) and 158 - 163 (Geometric). Cf. also Foley 1988, 81.

NOTE 268

Cf. K.-D. Nadeln, 158 - 161. As many as 12 pins might be placed in one tomb. For the so-called "spits" and the tubes in which the pair of pins might be placed, cf. pp. 83 - 84 and notes 313 - 317 below.

NOTE 269

Cf. Kilian 1975 a, 168 for the numbers of pins at the sanctuaries in question and K.-D. Nadeln, 162 - 163. More pins are now registered at Tegea, cf. Voyatzis 1990, 203. The only pin from the Argive Heraion with an inscription to Hera is the silver pin in the British Museum, K.-D. Nadeln, No. 4373, p. 249 and pl. 103. For repaired pins, cf. note 30 above.

NOTE 270

K.-D. Nadeln, 75, cf. IS I, 176 - 177, note 18. However, Rolley 1988, 346 (with reference to K.-D. Nadeln, 84 - 85) and Rolley 1992, 39, refers to finds of PG pin types in the Geometric tombs in the Argolid as well as in Achaia. There is thus a possibility that the two pins of PG type were offered at a later date at the Argive Heraion. Cf. also p. 86 and note 334 below.

NOTE 271

K.-D. Nadeln, nos. 202 and 226, cf. ref. note 270 above.

NOTE 272

K.-D. Nadeln, 85.

NOTE 273

Jacobsthal 1956, 3 - 13 and K.-D. Nadeln, 85 - 208, cf. also summary by Voyatzis 1990, 204 - 208.

NOTE 274

Geometric I A, K.-D. Nadeln, 86 - 90 and pl. 14. From AH come Nos. 370, 372 and 380 - 381 = Caskey - Amandry 1952, 181, M 49.104 and AH 89, 725 and 2533.

NOTE 275

Geometric I B, cf. K.-D. Nadeln, 90 - 92 and pls. 14 -16. The tomb contexts from Argos and Corinth, nos. 391 - 392, 398 - 399 and 403 are dated to EG on p. 92 but to MG in the list, pp. 90 - 91. For the AH finds, cf. IS I, 174 - 175 and note 19.

NOTE 276

Geometric I C, K.-D. Nadeln, 92 - 93 and pls. 16 - 17. nos. 430 and 435 - 436 = AH 733 and 735 and Caskey - Amandry 1952, 181, no. 102, M 49.105. The Tiryns example = K.-D. Nadeln, 92, no. 429.

NOTE 277

Geometric I D, K.-D. Nadeln, 93 - 105, pls. 17 - 27. From AH Nos. 451 - 927 passim, many of which have tremolo decoration, cf. AH II, pl. LXXXIV. For the chronology and distribution area, cf. K.-D. Nadeln, 104 - 105. Considering the large number of Geometric I D pins at the Argive Heraion, I do not quite understand I. Kilian-Dirmeyer's observation, op. cit. p. 162, that Geometric I pins are comparatively rare in sanctuaries. The absence in Olympia of this very large group of Northeast Peloponnesian pins may be another warning against overstressing the Argive - Olympia connection in regard to Geometric bronzes, cf. pp. 59 - 60 and notes 181 - 182 and 185 above and cf. p. 81 and note 289 below for apparently the same phenomenon regarding the Argos hammer pins, Geometric XVIII.

NOTE 278

Geometric II. K.-D. Nadeln, 105 - 109, nos. 937, 940, 942, 944, 946, 973 and 975 - 985 = AH 789 - 791, 973, 975 -985, 2551 - 2552, 2555, 2560 - 2561, 2567 - 2568, 2572 and 2580 -2582 and Caskey -

Amandry 1952, M. 49.79 and M 49. 113, p. 181, no. 103, pl. 46 and before no. 103.

NOTE 279

Geometric III, K.-D. Nadeln, 109 - 114, pls. 32 - 37.

Geometric III A. From the Argive Heraion come Nos. 990 - 1038 passim (III A 2), 1039 - 1048, i.e. the whole subgroup, III A 3 and 1049 - 1052, i.e. the whole subgroup III B. = AH 2589 -2594, 2596 - 2598, 2600 - 2602, 2604 - 2605, 2607 - 2610, 2612 - 2613 and 2613 a, 2619 - 2620, 2622 - 2624, one pin without AH No. and Blegen 1939, fig. 26. 2 and ADelt. 16, 1960, B, 82.

The Tiryns fragment is K.-D. Nadeln, no. 1035. The finds in Perachora are nos. 1020 and 1025 - 1028, those from tombs in Corinth are nos. 994 - 995 and 1006 - 1014. For the absolute chronology and the suggestion of Corinthian production, cf. K.-D. Nadeln, 112 - 113 and for Argive production of Geometric III B, p. 114.

For Rolley's observations, cf. Rolley 1988, 347, and Rolley 1992, 39.

NOTE 280

Geometric IV, K.-D. Nadeln, 114, pl. 38. The AH example is no. 1054 = AH 2625.

NOTE 281

Geometric V, K.-D. Nadeln, 115 - 116, pls. 38 - 39. From the Argive Heraion, nos. 1057 - 1074 passim = AH 2627 - 2634 and 2639 and one without AH No.

NOTE 282

Geometric VI. K.-D. Nadeln, 116, pl. 39. No. 1080 = AH 2644. For the Hera Sanctuary west of the Heraion, cf. note 297 below.

NOTE 283

K.-D. Nadeln, 117.

NOTE 284

Op. cit., p. 117 - 122. About 135 pin fragments come from the Argive Heraion.

NOTE 285

Geometric VIII - XII, K.-D. Nadeln, 122 - 135, pls. 44 -52. From the Argive Heraion, nos. 1327 - 1332, 1409 - 1412, 1432 and 1445, 1470, 1477 - 1483, 1494 and 1561 - 1562. = Geometric VIII (LG), AH 342 - 344 Geometric IX, AH 338 - 41 and AH 345 - 346. Geometric XI, Blegen 1939, 439 - 440, Fig. 27. Fragments of Groups VIII - XI, = AH 351.

Geometric XII = AH 334 - 335.

As there is also a fragment of this type, probably of Geometric IX, in the Aphrodision, cf. p. 82 and note 304 below, the types apparently continued at least into the late 7th Cent. BC.

NOTE 286

Geometric XIII - XV, K.-D. Nadeln, p. 135 - 139, pls. 53 -54. Geometric XIII, nos.1587 - 88 = AH 347 - 348.

(Geometric XV, no. 1611 A comes from Tiryns).

Geometric XVI op. cit. p. 139 - 144, pls. 55 - 60. From the Argive Heraion, nos. 1676 - 78, 1689 - 1698, 1732 = AH 321 - 333 and Delt. XVI, 1960, p. 82.

Geometric XVII, K.-D. Nadeln, 145 - 146, pl. 60, no. 1793 from Tiryns.

NOTE 287

K - D. Nadeln, 146, no. 1809 = AH 350.

NOTE 288

Geometric XVIII, Hammer pins, K - D. Nadeln, 147 - 150 and pls. 61 - 62, and Foley 1988, 83.

NOTE 289

K - D. Nadeln, 148 - 150, Geometric XVIII B - C, XVIII B = op. cit. nos. 1850 and 1859 - 1861 = AH 352 and 354 - 356. XVIII C = op. cit. nos. 1866, 1870 - 1873 A, 1875 -1880, 1883 - 1886, 1890 - 1897 and 1900 - 1904 = AH 353, 357 -379, 381 - 382 and Inv. no. 3325. Cf. also here Fig. 27 left, apparently not included in Kilian - Dirlmeier's list.

The Corinth example is K.-D. Nadeln, no. 1865 (XVIII C).

The Tiryns examples, op. cit. nos. 1868-69, 1874, 1881 -1883, 1888 - 1889, 1898 - 99 and 1905 are all XVIII C. whereas the Tegea examples represent XVIII B as well as XVIII C.

The hammer pins seem to be absent in Olympia, cf. also note 277 above, Geometric I D.

NOTE 290

Geometric XIX, K.-D. Nadeln. 151 - 152, pls. 62 - 63, nos. 1926 and 1926 A - B = AH 318 - 320.

The Tiryns pin, K.-D. Nadeln, no. 1929.

NOTE 291

Geometric XX, K.-D. Nadeln, 152 - 155, pls. 63 - 64, cf. Voyatzis 1990, 206. Cf. p. 82 and note 309 below.

Geometric XXI, K.-D. Nadeln, 155 - 156, pl. 64.

NOTE 292

K.-D. Nadeln, no. 1987, pl. 64 = AH 195 and no. 2012 = AH 336

NOTE 293

"Mehrkopf-Nadeln", K.-D. Nadeln, 163 - 203. Conclusions, p. 200 - 203, pls. 65 - 83. Nos. 2017 - 2963 passim (A and C -D) = AH 95 - 579 passim, Inv. No. 14037 a; Blegen 1939, 440, figs. 25 and 27 (two pins), Caskey - Amandry 1952, 181, nos. 94 - 95, M. 49.107 and 49.108 and ADelt 1960, p. 42 (4 pins).

The finds at the Argive Heraion of type K are K.-D. Nadeln, nos. 3184, 3186, 3195, 3203 and 3205 = AH 136, 152, 164, 183 and 311.

Kilian - Dirlmeier's variant K is a collection of different subtypes, cf. K.-D. Nadeln, 195.

The fragment of variant L is K.-D. Nadeln, no. 3314 = AH 184 A.

Cf. Foley 1988, 83.

NOTE 294

"Pilzkopf-Nadeln", K.-D. Nadeln, 203 - 206, pls. 83 - 84. Cf. pp. 81 - 82 and note 298 below.

NOTE 295

Roll pins, cf. K.-D. Nadeln. 206 - 207, pl. 84; the listed examples mostly from Olympia.

NOTE 296

AH 811 - 812 and NM 20732, with flat heads. Cf. AH II, 240, pl. LXXXIV. See also Tegea, Voyatzis 1990, 207 and notes 200 - 201 and Vitsa, pl. 126 d - e and drawings, pl. 115, c - d. From Tomb 35, p. 85 - 86 (8th Cent. BC).

NOTE 297

Pins at the **Hera Sanctuary west of the Heraion**:

Geometric I D, Blegen 1939, fig. 9, 5, NM Inv. no. 16603 = K.-D. Nadeln, no. 577, cf. p. 79 and note 277 above.

Geometric VI, Blegen 1939, fig. 9. 6, NM Inv. No. 16618 = K.-D. Nadeln no. 1079 , cf. pp. 79-80 and note 282 above.

Geometric XVIII. Hammer Pins. I suppose that the hammer pin K.-D. Nadeln, no. 1883, which, according to AH II, 215, note 2, was found at the "Heraeum tomb" should actually be seen in connection with the Hera sanctuary near the tholos tomb excavated later by Blegen.

"Mehrkopf-Nadeln", cf. Blegen 1939, 412 and fig. 3, NM Inv. nos. 16582, 16583 and 16586 = K.-D. Nadeln nos. 2057, 2120 and 2260.(Types A and C).

NOTE 298

For pins from the votive deposits of the **Mycenaean tombs**, cf. the list by Blegen 1937, 379 and fig. 2; the pin from Tomb XLIX is without its head and not classifiable and three are of Archaic types. Geometric "Mehrkopf-Nadeln", K.-D. Nadeln, no. 2331, p. 172, pl. 70, (Type C) from Tomb XL, cf. Prosymna, fig. 323. Cf. p. 81 and note 293 above. "Pilzkopf-Nadeln", K - D. Nadeln, no. 3331, p. 203 and 206, pl. 83, from Tomb IX, cf. Blegen 1937, 379, fig. 2, 3. Here Fig. 36. Cf. p. 81 and note 294 above.

NOTE 299

For the Geometric pins in the Argos tombs, cf. in particular, Courbin 1974, 130 - 131 and Foley 1988 80 - 83.

NOTE 300

Argos. Geometric I. Geometric I A pins, K.-D. Nadeln, nos. 338 - 339 and 368 - 369. For AH cf. p. 78 and note 274 above. Geometric I B, K.-D. Nadeln, nos. 398 - 399. For AH, cf. p. 78 and note 275 above. (Geometric I C cf. K.-D. Nadeln, 92 - 93 and p. 78 and note 276 above for the AH and Tiryns finds). The greater part of the Argos pins are Geometric I D, cf. K.-D. Nadeln, 93 - 103. In Argos, Geometric I D, nos. 441 - 450, 469 - 474, 478 - 479, 483 - 484, 509, 522, 524, 529 - 530, 533, 541 - 542, 550 - 551, 573, 578, 585 - 586, 592 - 593, 599 - 600, 679, 681, 683, 687 and 929 - 935. For AH Geometric I D, cf. pp. 78 - 79 and note 277 above.

NOTE 301

Geometric II. K.-D. Nadeln, no. 974, p. 108, pl. 30. For AH, cf. p. 79 and note 278 above.

NOTE 302

For Geometric III, cf. p. 79 and note 279 above with reference to Rolley. K.-D. Nadeln, 109 - 114, does not list a single example from Argos.

NOTE 303

Geometric IV - VI, cf. K.-D. Nadeln, p. 114 - 116 and p. 81 and notes 280 - 282 and 297 above for finds in and around the Argive Heraion. (Geometric VII is seen in only two examples in Perachora, cf. p. 80 and note 283 above).

NOTE 304

For Geometric VIII - XIII, cf. K.-D. Nadeln, p. 122 - 138 and for AH finds, cf. p. 80 and notes 285 - 286 above.

NOTE 305

For Geometric XIV - XV and XVII, cf. K.-D. Nadeln, 138 - 139 and 145. Cf. pp. 80 - 81 and note 286 above.

NOTE 306

Geometric XVI

Cf. K.-D. Nadeln, nos. 1710, 1726 and 1774; the first from a tomb at the Deiras, the others from the Athena sanctuary (B 69 and 70). Among the Aphrodision material is a pin head, 74/31, L. 10 cm., the closest parallel for which seems to be K.-D. Nadeln, No. 1705. It is broken below the head, where a hole indicates an ancient repair. For the AH finds, cf. note 286 above.

NOTE 307

Geometric XVIII, Hammer pins, cf. K.-D. Nadeln, 147 - 150. The majority of these pins come from the Argos tombs and Geometric XVIII A are found here only.

Cf. Foley 1988, 83. On the Larissa sanctuary, B 72 = K.D. Nadeln, no. 1862, p. 149 and pl. 6,1, here Fig. 32. (Geometric XVIII B). From the Aphrodision a possible fragment of the cross of a hammer pin. no. 70/561. L. 4.3 cm. and a certain of a large conical disk, 73/594. Diam. 3.5 cm. For hammered pins at the Argive Heraion, cf. p. 81 and note 289 above and for the small Hera sanctuary, p. 81 and note 297 above. Cf. also p. 86 and note 339 below.

NOTE 308

Geometric XIX, K.-D. Nadeln, nos. 1910 - 1911, 1923 - 1924 and 1928 from Argos Tombs and possibly the Aphrodision. no. 74/54, a conical pin head, L. 1.5 cm. and a head with part of the pin, like K.-D. Nadeln, no. 1921, preserved L. 4.5 cm. Diam. of head, 0.5 cm.

NOTE 309

Geometric XX, the flat-head pins, cf. K.-D. Nadeln, nos. 1946 - 1948 from tombs in Argos and nos. 1936 and 1939 - 40 from Tiryns and no. 1945 from Mycenae. Cf. note 340 below.

NOTE 310

"Mehrkopf-Nadeln", K.-D. Nadeln, nos. 2026 and 2052 (Athena Sanctuary. Larissa, both B 83), 2053 - 54, 2075 - 77 (Tombs in Argos), 2166 = Vollgraff 1956, 49, fig. 38 (Apollon Pythaeus Sanctuary), all type A, and 2418 and 2423 and 2504 as well as Vollgraff, Br. 1866, (L. 11 cm)(Athena Sanctuary. Larissa), all Type C. One in the Aphrodision, OBC 34 (L. 11.8 cm.), Type C. Cf. also Foley 1988, 83.

NOTE 311

Foley 1988, 83 - 84 and cf. pp. 78 - 79 and notes 276 and 279 above for the pin types Geometric I C and Geometric III known from tombs in Mycenae, Tiryns or the Corinthia as well as from sanctuaries.

NOTE 312

Cf. pp. 79-80 and notes 280 - 282 and 285 above for Geometric I and pp. 81 - 83 and notes 293 and 311 above for the "Mehrkopf-Nadeln". Cf. pp. 78 - 79 and notes 276 and 279 above for Geometric I C and Geometric III, esp. III A 3 and B, both with a possible production at the Argive Heraion; and cf. pp. 81 - 82 and notes 289 and 308 above for Geometric XVIII, the hammer pins; and pp. 81 - 82 and notes 291 and 309 above and note 340 below for Geometric XX, the flat-head pins.

NOTE 313

The long pins which De Cou called spits are AH 2273 - 2711, AH II, 300 - 323, pls. CXXVII - CXXXIII, as well as about 2,000 discarded items.

I. Kilian - Dirlmeier's Geometric I A, I D, III and IV - VI are mostly of Northeast Peloponnsian manufacture.

Jacobsthal 1956, 13 - 15 and 114 - 115. In my opinion, Jacobsthal is correct in not distinguishing between pins and so-called "spits", i. e. long pins, which on p. 15 he interprets as ritual pins made not for mortals, but for Hera.

On p. 14 he gives a list of the provenances known in 1956, which apart from the Northeast Peloponnesian sites include a few "spits" from each of the following places: Athena Aphaia on Aigina, the Amyklaion, the Athenian Acropolis, Delphi, Dodone and Tegea. Since then they have been found also in Argos tombs, cf. Courbin 1974, Tombs 175 and 176, 2, p. 118 and pp. 72 - 84, pls. 46 and 48. (Both LG II).

The second largest find after the Argive Heraion is apparently Perachora, cf. Perachora I, 71 - 72, pl. 17 (Hera Akraia) and 175, pl. 77 (Hera Limenia).

K.-D. Nadeln, 162.

Foley 1988, 82 - 83 and 138.

NOTE 314

The longest pin fragments at the Argive Heraion are AH 2287, measuring 68.2 cm.; AH 2477, 77.2 cm. and AH 2581, 82.7 cm. At Perachora the largest fragment measures about 60 cm., cf. Perachora I, 175. In the Argos tombs, Courbin, loc. cit., the pins measure between 30 and 40 cm. and the same applies to Tiryns Tomb XXV,

Verdelis 1963, 42 - 43 and fig. 14. In Corinth, Tombs F - G, they measure 60 cm, Jacobsthal 1956, 14 and fig. 23.

NOTE 315

For the tubes, cf. ref. Foley 1988, 82 and, in particular, Tiryns Tomb XXV, 2, Verdelis, loc. cit. and Argos, Tombs 175 and 176, Courbin loc.cit.

For tubes from the Argive Heraion, Foley, loc. cit., and note 22 gives references to AH 1496 and 1498, AH II, 262 and pl. XCI; also AH 1497, AH 1513 - 1518 and 1524, loc. cit., are of the same types and presumably tubes.

For offerings of long pins in pairs in the Corinthian tombs cf. Jacobsthal 1956, 15 and K.-D. Nadeln, 161 - 162.

NOTE 316

Cf. Courbin, loc. cit.

NOTE 317

Cf. note 313 above, ref. to Jacobsthal, K.-D. Nadeln and Foley. As Jacobsthal pointed out, p. 13, the long pins are extremely unsuited as meat spits; they are very thin and furnished with knobs, and they differ a great deal from the iron spits which definitely were used as such.

(I cannot, as Foley seems to do, take Verdelis' suggestion of knitting needles, Verdelis 1963, 43, seriously.)

NOTE 318

For Jacobsthal's arguments, cf. note 317 above. For the long pins from the Altar Area, cf. IS I, 176, note 33 (AH 2301 and 2704) as well as AH 2492 from the NE corner of the Second Terrace (AH II, 310). From the West Building come ca. 20 pins and from either the Southern Slope or the Back of the South Stoa, likewise secondary find spots, ca. 25 pins. The bronze rods mentioned by Waldstein as found in the Archaic Temple are, judging from the context, presumably not pins, cf. IS I, 201.

NOTE 319

Cf. Jacobsthal 1956, 114 - 115 and several examples AH II, pls. CXXVIII - CXXXI.

NOTE 320

Two of the pins, Vollgraff Br. 1855, are twisted in the said forms; one, is formed into a double loop (its L. is 4 cm., W. 2.5 cm.); the other is made into a quadrangular ornament with several loops or spirals along two of the edges, in the present form measuring 4.5 x 2.5 cm.; it is similar to Voyatzis 1990, B 255, p. 213 and pl. 166, but apparently not made into a fibula like

the Tegea example = Blinkenberg III 6 c, p. 82.

A few fragmentary wires in the Aphrodision were apparently bent into similar ornaments, 73/547 and 73/596.

From the Argive Heraion, cf. e.g., AH 195 = K.-D. Nadeln, no. 1987; AH 746, AH II, pl. LXXXIV and AH 826, AH II, pl. LXXXV.

NOTE 321

AH 2007 (NM 20591), AH II, 285 and pl. CXVII. A Protocorinthian skyphos rim fragment with a small fragment of handle and possibly the skyphos handle, AH 2048 (NM 20661), AH II, 285 and pl. CXIX. AH 2044 (Diam. 2.2 cm.) and AH 2082 (Diam. of button 1.65 cm., AH II, 288, pl. CXIX and 289 - 290, pl. CXXI, may perhaps be fragmentary buttons of pyxis lids, cf. Perachora I, 156, pl. 60, 9 and 10.

Both types are better represented in the neighbouring votive deposits, cf. note 326 below.

The production of miniature vases and other miniature objects as for example mirrors, presumably began before 700 BC, but as shown by one of the most common forms, the lotus phiale, they belong for the greater part in the Archaic Period.

NOTE 322

Cf. e.g. the parts of horse trappings, AH 1555 and AH 2783, AH II, 328 and pl. CXXXIV; Bouzek 1974 a, 157 - 160 and fig. 46, 5, B 1 (AH 2783) and C 2 (AH 1555) p. 158, dated to presumably not earlier than about 650 BC, cf. Bouzek 1974 b, 311, and Bouzek 1982, 56 - 57, Nos. 16 B - C. For fragments of carriages and of wheels, cf. AH 2253 - 2255 AH II, 298 - 299, pl. CXXXVI.

NOTE 323

Cf. e.g. the spear head mentioned in Brownson 1893, 210, which was found at the Gymnasium. A spear butt, AH 2712, cf. AH II, 213 and pl. CXXXIII.

NOTE 324

AH 2757 (NM 13990), AH II, 326 and pl. CXXXIV.

Conical boss, cast in one piece with the bronze plate from which it is hewn off, leaving sharp cuts along the edges. H. 10 cm., lower diameter 6.7 cm.; the actual boss measures in height 6 cm. Its inside is hollow to a length of 2.6 cm. The tip of the buckle which has a diameter of 0.7 cm. shows traces of blows. The plate measures 0.3 cm. in thickness; its outside is well polished and has a series of concentric relief

rings on the lower outer part; its inside is finished.

For shield or belt bosses, cf. Snodgrass 1964, 37 - 51; Snodgrass 1973; Fellmann 1984; Vitsa, 304 - 305, Fig. 84 a - b and pl. 123, from Tombs 34 and 79. (MGII).

NOTE 325

AH 1779 - 1793, AH II, 271 and pls. CIII - CIV. They were found mostly in the West Building, on the Southern Slope or behind the Back of South Stoa. About 50 pieces were discarded.

I cannot tell their function. (The sheet with punched decoration will be treated in the following article.)

The two leaves, AH 1847 - 1848, AH II, 274 and pl. CVIII.

AH 1847. L. 7.15 cm. and AH 1848 L. 11.3 cm.

NOTE 326

The Hera sanctuary west of the Heraion: A fragmentary PC skyphos and several pyxis fragments are mentioned, Blegen 1939, 420, cf. fig. 9, 1, which Blegen 1937, 381, said were exactly like the pyxis from Prosymna Tomb VIII, cf. below.

The Prosymna deposits: Blegen 1937, 381, Tomb IX, crushed skyphos of PC type. Prosymna Tombs VIII and IX, Blegen 1937, 381, fig. 4, No. 2. Pyxis fragments, cf. Perachora I, 156 and pl. 60.

"Kalotten-Schale", cf. Blegen 1937, 380 and fig. 6.2. Tomb XL. Here Fig. 47.

For "Kalotten-Schalen", Mathäus 1985, 71 - 108, esp. 100 and note 59 with ref. to Geometric finds in Greece and cf. for finds in Argos tombs, Courbin 1974, 129 - 130, pls. 36 and 48.

NOTE 327

For "Kalotten-Schalen" in Geometric Argos tombs, cf. ref. note 326 above.

NOTE 328

B 78. Bronze ornament ca 10 cm. in length, somewhat resembling an ornament from Thermon which Kilian 1979, fig. 4, 7 - 9 and p. 38 connects with votive swords from Tegea and Sparta.

Another large ornament from Vollgraff's excavations on top of the Larissa, Br. 1865, is apparently an ornamental nail, measuring in length 10.4 cm.; it is fragmentary, with a shaft of quadrangular section, each side measuring 1.3 cm. and a globular head, measuring 2.5 cm. in diameter, above which is a break, cf. Perachora I, 181, pl. 82, 11. Among the Larissa finds as well as in the Aphrodision were also several implements of iron, including at both sites a miniature

axe. Larissa: F 59, cf. Courbin 1974, 135. Aphrodision, 74/31. L. 6.2 cm.

NOTE 329

Vollgraf Br. 1857. Cast bronze arrow head with a small tang. Length with tang, 4.2 cm., without 3.7 cm. Aphrodision, 71/62 bis and 73/562, the latter measures 3.5 cm. Cf. Voyatzis 1990, 201 for an example from the Athena Alea sanctuary at Tegea, with ref. in notes 131 - 132 to other sanctuaries with votive arrow heads and to Dugas 1921, 389, Nos. 178 - 180, Fig. 41. Cf. also Snodgrass 1964, 144 - 156, Greek arrow heads of bronze, in general. The stone arrow head, Simon 1986, 288, no. 14, from the Argive Heraion, AH II, 354, is presumably Prehistoric.

NOTE 330

Argos, Tombs 45, Courbin 1957, (helmet and cuirass, pls. I - IV and figs. 19 - 45), Snodgrass 1964, 13 - 16 (helmet) and 72 - 84 (cuirass) and Courbin 1974, 135 note 7, 40 - 41 and frontispiece, and for helmets, cf. also Protonotariou-Deilaki 1984, 43 - 45, figs. 2 - 4 and 6 - 7; cf. also Foley 1988, 86 - 88. For bronze weapons in Argos tombs, in general, cf. Courbin 1974, 133 - 135.

NOTE 331

Cf. Voyatzis 1990, 198 - 200, pls. 135 - 141 for miniature votive shields and swords in Arcadian sanctuaries and references to such finds in Olympia and the Dipylon. There are not any certain finds of miniature shields at the Argive Heraion and we have no information, as stated by Aupert 1984, 25, that the shield was a prize at the contests for the Argive Hera before the 4th Cent. BC, cf. note 359 below (Amandry). Nor is there any evidence that the Archaic Argive Heraion received dedications of arms and armour like other important Archaic sanctuaries; cf. Snodgrass 1967, 48 for the change in custom from burying men with their arms in the Geometric Period to dedicating arms in the sanctuaries in the Archaic Period.

NOTE 332

For the chronology of the Argive ceramic phases, cf. Coldstream, 1968, 330, and end of note 160 above.

NOTE 333

Cf. the Argos sanctuaries, note 7 above. For the possible MG II date of the hammer pins on the Larissa, cf. p. 86 and note 339 below.

NOTE 334

K.-D. Nadeln, nos. 202 and 226, cf. notes 270 - 271 above with ref. to Rolley. However, I see no reason for R. Hägg's suggestion, Hägg 1992, 15 and 20, that the ordinary bronze pins of PG type at the Argive Heraion are heirlooms; nor like the PG material at Amyklaion (cf. Calligas 1992, 41 and 43 - 44) can they be considered a sign of early Post-Mycenaean habitation, of which we have no trace at or near the Argive Heraion. The only vague mention of such in the Prosymna area is ADelt. 37, 1982 (1990), B 94, cf. AR 1990/91, 22, a plundered cist grave, Geometric or earlier, near the church of Agios Nicolaos, a few km. from the Heraion. At any rate, the two PG bronze pins initiate a long and continuous development of such votive dedications at the Argive Heraion, gradually increasing in number of preserved examples. Although we have only one pin with a dedicatory inscription to Hera at this site, cf. note 269 above, the general votive character of the pins at the Argive Heraion has never been doubted.

NOTE 335

Cf. IS I, 175 - 176, for unpublished pottery finds earlier than MG II.

NOTE 336

Cf. pp. 78-79 and 81 and notes 274 - 277 and 288 - 289 and p. 82 and notes 300 and 307 above.

NOTE 337

Cf. IS I, 175 and note 19 and ref. notes 334 - 335 above. Although some of the simple arched fibulae may be early, their date is not certain, cf. IS I, 174, note 17.

NOTE 338

Cf. pp. 79 and 82 and notes 278 - 279 and 301 - 302 above.

NOTE 339

Geometric XVIII B. K.-D. Nadeln, nos. 1852 - 54, from Argos, Tomb 6, nos. F 7 - 8, cf. Courbin 1974, 14 - 22, pl. 22 (MG II). For AH finds, cf. note 289 above. For the Larissa find, cf. note 307 above.

NOTE 340

Cf. notes 291 and 309 above. K.-D. Nadeln, pp. 152 - 155. Kilian-Dirlmeier sees a difference in the distribution pattern in Arcadia and the Argolid, in the former region coming from sanctuaries, in the latter from tombs. However, the find from the Perseia at Mycenae need not come from a tomb context, cf. Wace 1953, but possibly a My-

cenaean water reservoir used until the Geometric and Orientalizing Periods. For the differences in detailed decoration of the Argos and Tegea pins, cf. K.-D. Nadeln, 154.

NOTE 341

For the chronology of the Solid Cast Tripods found at the Argive Heraion, cf. p. 50, all dated towards the end of the production phase which presumably stops around 750 BC. The bronze tripod finds at Mycenae and Tiryns are all considered Mycenaean or Protogeometric, cf. note 108 above.

For the chronology of the Boiotian arm rings, spectacle fibulae and plate fibulae, cf. pp. 70, 72 - 73 and 75 and notes 235, 247 and 254 above, and for the simple arched fibulae, cf. note 337 above.

NOTE 342

Cf. pp. 81 and 83 and notes 293 and 310 above.

NOTE 343

Cf. pp. 83 - 84 and notes 313 - 314 and 320 above.

NOTE 344

Argive Heraion.

For Laconia, cf. pp. 53, 64 - 65 and notes 138, 204 and 207 above.

Of the Laconian type pins, only one of the "Mehrkopfnadeln" types which also were found elsewhere in Northeast Peloponnese comes from the Argive Heraion, cf. p. 81 and note 293 above.

For Arcadia, cf. pp. 55 - 57, 62 - 67, 72 - 76, 79 - 81 and notes 149, 155 (AH 20), 156, 162 - 164, 197, 204 - 209, 211, 223, 243, 249, 251, 255 - 256, 278 and possibly 285 - 287 above (either Central Peloponnese or Arcadian).

For the Corinthia, cf. pp. 53, 78 - 79 and 84 and notes 138, 276, 279 and 321 above.

For Central Greece, cf. pp. 53, 62 - 64, 69 - 70, 73 - 76, and notes 138, 198 - 200, 202, 235 and 251 - 256 (for which, however, a Peloponnese production is more likely).

For Thessaly, cf. pp. 64 - 66, 69, 72 - 74 and notes 203, 205, 211, 234 (Thessalian-Macedonian arm ring), 245, 247 and 251 above.

For Macedonia, cf. pp. 67 - 69, 73 and 84 and notes 224 - 226, 234, 247 and 322 above.

And for the West Peloponnese, cf. p. 81 and note 291 above.

For the genuinely insular fibulae, cf. p. 73 and note 250 above.

NOTE 345

Argos.

For the Central Peloponnesian pins and pendants, cf. pp. 68 and 82 and notes 228 - 229, 301, 304 - 306 and 309 above. For differences in types represented at Argos and the Argive Heraion, cf. especially the ring pendants, p. 68 and note 229 above, the double axe pendants, pp. 67 - 68 and notes 222 and 228 above and the flat-head pins with production in both Argos and Arcadia, pp. 82 and 86 and notes 309 and 340 above.

For a Thessalian type fibula, cf. p. 77 and note 264 above and for the Boiotian fibulae, both types presumably of Peloponnesian origin, p. 77 and note 265 above. For the Central Greek bird type, p. 66 and note 216 above.

NOTE 346

Cf. in particular, the insular fibulae, p. 77 and note 264 above.

NOTE 347

Cf. for Arcadia pp. 53 - 59, 62 - 68, 73 - 76, 79 - 81 and 82; for Corinthia pp. 53, 78 - 79 and 84 and for Central Greece and Thessaly pp. 53, 62 - 66, 69 - 76.

NOTE 348

However, the flat head pins may not be taken as Argive imitations of Tegea bronzes, the similar pin types at the two sites, may be due to similar traditions.

NOTE 349

Cf. pp. 86 - 87 and references note 344, for the Argive Heraion relations with the Corinthia. For the Northeast Peloponnesian earrings, cf. pp. 69 - 71 and notes 232 - 233 and 238 above. For Laconian influence on the Argos warrior's statuette, Fig. 23, cf. p. 61 and notes 189 - 191 above.

NOTE 350

Cf. p. 84 and notes 321 and 326 - 327 above.

Although the Protocorinthian vase fragments of bronze at the Argive Heraion are so few and small, they correspond with those at the neighbouring Hera sanctuary and bronze vases are, in general, so well represented at both sanctuaries that the apparent absence of the so-called "Kalotten-Schale" is presumably real. From Corinth, we have no record of a "Kalotten-Schale".

NOTE 351

Cf. pp. 84 - 85 and notes 328 - 330 above.

NOTE 352

Cf. AH 11 - 13, chariot horses, pp. 56 - 57 and Figs. 17 - 20 and notes 148, 153 and 159 and for the Argos horse, pp. 60 - 61 and Fig. 22 and note 187, and for the comparison between them, cf. p. 61

For the significance of votive statuettes of horses, in general, cf. Bevan 1986, 322.

NOTE 353

Cf. p. 50

NOTE 354

Cf. p. 51 - 52

NOTE 355

The Argive Geometric pottery is strongly influenced by Attica throughout its whole line of development, as shown by Coldstream 1968, chpt. IV, 112 - 146, cf. Courbin 1966, 510 - 515, and only in the LG period, when also Attic pottery is influenced from Corinth, shows Corinthian influences, cf. esp. Coldstream 1968, 130 - 131, but never to the same extent as from Attica. Cf. also Courbin 1966, 515 - 520.

NOTE 356

Kelly 1976, chpt. IV, esp. pp. 60 - 64. Kelly connects his theories with the destruction of Asine by Argos in the late 8th Cent. BC and discusses the possibility of a religious-political league with Argos as the leading power.

NOTE 357

Polignac 1984, chpt. 2, pp. 41 - 92, esp. pp. 59 - 60.

For objections of a chronological and religious character, cf. below.

In his article, Polignac 1990, he differentiates his theories more. I have not seen his article in Argos et l'Argolide. Topographie et Urbanisme. Actes du Colloque Intern. de l'École Française d'Athènes (May 1990). A detailed discussion of de Polignac's theories will be postponed until my concluding article.

NOTE 358

Morgan - Whitelaw, 1991, esp. pp. 84 - 86. Until the early pottery from the Argive Heraion is published (cf. IS I, 173 - 174), it is not possible to compare the Geometric pottery of Argos with that of the Argive Heraion and the authors' personal observation on this point, op. cit. p. 84, with note 22, is undocumented. Nor do I find the Geometric pottery of the site actually incorporated in the study (e.g. the Argive Heraion is not included in the four maps of fig. 6.) Considering the evidence for early

bronze manufacture at the Argive Heraion, I find the suggestion by Foley 1988, 66, of local potteries at the Heraion quite possible, unlike the authors.

NOTE 359

E.g. we have no evidence for the military aspect of the early Argive Hera as stated by de Polignac 1984, 59 - 60, cf. 54. Her cult statue was unarmed (cf. the many terracotta figures of seated unarmed women at the site, AH II, pls. XLII - XLIV), and we have no information of the shield having been introduced as an athletic prize until the 4th Cent. BC. The prizes in the 5th Cent. BC were bronze hydriai and other vessels, cf. Amandry 1980, 211 - 217, and for the shield as a prize in the 4th Cent. BC and Imperial Roman Times, 231 - 233.

We have no information about the procession from Argos to the Heraion earlier than Herodotus' story about Kleobis and Biton, in itself not securely dated, and the situation of the Kourtaki sanctuary (for both cf. Morgan - Whitelaw 1991, 84) is not a certain indication of connection with such an early processional road (cf. op. cit. p. 80, fig. 1). Its Geometric votives comprised only pottery and terracottas. Cf. note 8 above.

NOTE 360

A thorough discussion of the problem presupposes a more general background concerning the emergence of the Greek city-states and cannot take place here; it belongs in my final and more general paper on the questions concerning the Early Argive Heraion.

NOTE 361

Cf. in particular, Wright 1982, esp. Hera and the Hero Cult pp. 193 - 194 and p. 200: "...the tombs... may have been the catalyst for Hera worship on this spot..." and cf. Whitley 1988, esp. p. 179: "...the appearance of offerings in these tombs must be intimately related to the construction and foundation of the Argive Heraeum itself... the motivation... must have been largely the same."

For the small Hera sanctuary, cf. note 366 below.

NOTE 362

The Hera Sanctuary, cf. Blegen 1939, 410 - 427. The votives continue into the Classical Hellenistic Periods, cf. op. cit. p. 42. The Prosymna Tombs, cf. Blegen 1937, pp. 377 - 390 (the end of the 8th Cent. BC and the early part of the 7th); Coldstream 1968, 406. Coldstream 1976, in particular,

p. 9 ("the offerings... begin in the late eighth century"); Wright 1982, 193 - 194; Whitley 1988, 179 and Hägg, 1987 b, esp. conclusions, 98 - 99. Antonaccio 1992, esp. p. 99. I am not convinced of her MG II date of the skyphos, pl. 214 b = Blegen 1937, fig.13; in form and decoration it may just as well be LG, cf. Coldstream 1968, 125 - 129 and e.g., Courbin 1966, pls. 60 and 64.

NOTE 363

Cf. pp. 86 - 87 (EG/MG) and esp. the summary of MG II.

NOTE 364

Cf. the references in note 362 above. For LG hero-cults in the Mycenaean chamber tombs in Argos, cf. note 7 above.

NOTE 365

Blegen 1939, 412 and fig. 11.

NOTE 366

Cf. ref. in note 362 above. The only bronze object which does not have parallels in the Argive Heraion is the fibula, p. 76 and Fig. 35 and note 258 above which, however, does not indicate a different tradition. For the terracottas, cf. esp. Blegen 1939, 420 - 423 and for the pottery, op. cit., p. 423 - 427.

For the suggestion that the Hera cult grew of a hero-cult, cf. Wright 1982, 194.

NOTE 367

Cf. Blegen 1937, 377 - 8 and **Prosymna**, 262 - 263. The deposits in **Tomb III**, **Prosymna**, 180, and **Tomb XIII**, **Prosymna**, 194, are of 4th Cent./Hellenistic date, coming from a potter's kiln and a child's burial, respectively, while a large shaft or pit in **Tomb X**, **Prosymna**, 197 - 198, was dug around 600 BC or later, filled with debris which contained Corinthian and earlier pottery as well as a fragment of a terracotta figurine.

Both **Tomb II** and **Tomb XLIII** have later fills in the dromos consisting of Geometric/Archaic sherds as well as Classical or Hellenistic finds. As regards Tomb II (and possibly both tombs), these finds may be viewed in connection with the kiln in neighbouring Tomb III, cf. **Prosymna**, 174 and 180 and fig. 440 (Tomb II) and p. 186 and figs. 467 and 487 (Tomb XLIII).

Tomb XLIX, **Prosymna**, 136, had numerous Geometric ceramic fragments and bronze bits, but apparently not a genuine deposit.

All the above tombs were situated north of and near the Argive Heraion, a bit further away from the Heraion, but in the same area as Blegen's finds of three large fragmentary early bronzes, Blegen 1939, 427 - 430, fig. 16, cf. IS I, 192 - 193, fig. 16. The tombs are indicated on the detail of the plan, op. cit. fig. 15. There may well have been fragments of pottery and metal lying around in the area.

Tomb XXV, mentioned by Blegen 1937, 377, did not contain Post-Mycenaean finds according to **Prosymna**, 86 - 92. Perhaps the skyphos, Blegen 1937, 386 - 387 and fig. 13, cf. note 362 above, is erroneously attributed and should belong with neighbouring Tomb XXVI which included "a nest of Geometric pots", cf. **Prosymna**, 93. Antonaccio 1992, 99, note 42, refers to a burial in Tomb XXV, mentioned in Blegen's 1927 note book. A Geometric burial is without parallel in the Mycenaean **Prosymna** tombs.

NOTE 368

Blegen 1937, loc. cit. For the Geometric deposit in each tomb, cf. **Prosymna**, 161 (Tomb VIII), 165 (Tomb IX), 60 (Tomb XIX), 93 (Tomb XXVI), 111 - 112 (Tomb XXXIV), 124 (Tomb XXXVII), and 133 and fig. 319 (Tomb XL).

Tomb L had the outer end of its dromos cut away in Geometric times, but in the chamber was a Geometric fill with pot sherds and bronze bits and at the back a large heap of stones which may have formed a construction, cf. **Prosymna**, 140.

NOTE 369

Cf. Blegen 1937, 378, where another goat's skeleton is mentioned from Tomb XLVIII, a tomb which, however, did not have any Post-Mycenaean deposit, cf. **Prosymna**, 216. The finds of a few animal bones and dogs' teeth in Tomb XL (**Prosymna**, 133) are probably fortuitous. Cf. Hägg, 1987 b, 98 - 99.

NOTE 370

In K.-D. Nadeln, 201, Kilian-Dirlmeier suggests that the deposit of Tomb XL with only two bronze objects and three Proto-corinthian vases is a closed deposit. The same suggestion, p. 205, for Tomb IX with a large and varied deposit, cf. Blegen 1937, 378, does not appear convincing to me, although the ceramic material is homogeneous and not later than the early 7th Cent. BC.

NOTE 371

Cf. Hägg 1987 b, 99 and note 59, with reference to an observation by Coldstream that one of the vases was painted by a man who specialized in votive ware.

NOTE 372

Hägg, op. cit. 99.

NOTE 373

Cf. pp. 81 - 82 and note 298 and p. 84 and Figs 36 and 47 and note 326 above.

NOTE 374

For my conclusions regarding the monumental architecture of the Early Argive Heraion, cf. IS I, 198 - 200.

NOTE 375

In a following article, the Archaic Greek bronzes will be studied. These aspects which could not be entered into in this article will be studied in a final article. Two previously published articles have dealt with separate aspects of the foreign relations and the economy of the Early Argive Heraion, cf. IS II and IS III.

Bibliography

- Alexander, J. 1965
The Spectacle Fibulae of Southern Europe. *AJA* 69, 17 - 23.
- Alzinger, W. 1978
Aigeira 1976/77. *AAA* 11, 147 - 156.
- Alzinger, W. 1981- 82
Aigeira - Achaia. *ÖJh* 53, Beiblatt. Grabungen 1978 - 81, 8 -15.
- Alzinger, W. 1985
Aigeira - Hyperesia und der Siedlung Phelloë in Achaia, 1. Akropolis. *Klio* 67, 426 - 450.
- Amandry, P. 1980
Sur les concours Argiens. *BCH Suppl.* VI, 211 - 253.
- Andronikos, M. 1969
Vergina I. Athens.
- Andronikos, M. 1984
Vergina. The Royal Tombs and the Ancient City. Athens.
- Antonaccio, C.M. 1992
Terraces, Tombs, and the Early Argive Heraion. *Hesperia* 61, 84 - 105.
- Antonaccio Sanpaolo, E. 1990
Le leghe bronzee greche ed il progetto "Cuprium". *RdA* XIV, 104 - 126.
- Aupert, P. 1984
Argos aus VIIIe - VIIe siècles: bourgade ou métropole? *ASAtene* LX (1982), 21 - 31.
- Benton, S. 1938 a
Excavations in Ithaca III, *BSA XXXV* (1934 - 35), 45 - 73.
- Benton, S. 1938 b
Evolution of the Tripod-Lebes, *BSA XXXV* (1934 - 35), 74 - 130.
- Benton, S. 1950
The Dating of Horses on Stands and Spectacle Fibulae in Greece. *JHS* LXVIII, 16 - 22.
- Benton, S. 1953
Further Excavations at Aetos. *BSA XLVIII*, 255 - 358.
- Bevan, C. 1986
Representations of Animals in Sanctuaries of Artemis. Oxford. (*BAR* 315).
- Birge, D.E. - Kraynak, L.H. - Miller, S.G. 1992
Excavations at Nemea I. Berkeley - Los Angeles/ Oxford.
- Blegen, C.W. 1937
Post-Mycenaean Deposits in Chamber-Tombs. *AEphem* 1937 I, 377 - 390.
- Blegen, C.W. 1939
Prosymna: Remains of Post-Mycenaean Date. *AJA* XLIII, 410 - 444.
- Boardman, J. 1963
Island Gems. *JHS Supplementary Paper*. 10. London.
- Boardman, J. - Buchner, G. 1966
Seals from Ischia and the Lyre-Player Group. *JdI* 81, 1 - 62.
- Boardman, J. 1967
Archaic Finger Rings. *AntK.* 10, 3 - 28.
- Boardman, J. 1970
Greek Gems and Finger Rings. London.
- Boardman, J. 1990
The Lyre Player Group of Seals. An Encore. *AA* 1990, 1 - 17.
- Bohen, B. 1988
Die geometrischen Pyxiden. *Kerameikos* XIII. Berlin.
- Bol, P.C. 1985 a.
Zur Unterseite einer geometrischen Bronze-Gruppe im Liebighaus. *StädJb* 10, 7 - 12.
- Bol, P.C. 1985 b.
Antike Bronzetechnik. München.
- Bol, P.C. - Weber, T. 1985
Bildwerke aus Bronze und Bein aus minoischer bis byzantinischer Zeit. Liebighaus Museum Alter Plastik. Antike Bildwerke II. Melsungen.
- Born, H. - Moustaka, A. 1982
Eine geometrische Bronzestatuette im originalen Gussmantel aus Olympia. *AM* 97, 17 - 23.
- Bosshard, F. 1990
Protogeometrische Bronzefiguren in Basel. Zu Stil und Proportion früher griechischer Statuetten. *AntK.* 33, 3 - 19.
- Bouzek, J. 1967
Die griechisch-geometrischen Bronzevögel. *Eirene* VI. 1967, 115 - 139.
- Bouzek, J. 1971
Die griechisch-geometrischen Bronzevögel. Ein Nachtrag. *Eirene* IX., 89 - 93.
- Bouzek, J. 1974 a
Graeco-Macedonian Bronzes. (Analysis and Chronology). Prag.
- Bouzek, J. 1974 b
Macedonian Bronzes. Their Origin, Distribution and Relation to Other Cultural Groups of the Early Iron Age. *Pamatky Archeologicke*, 278 - 341. Prag.
- Bouzek, J. 1982
Addenda to Macedonian Bronzes. *Eirene* 18, 35 - 59.
- Brize, Ph. 1991
Archaische Bronzefiguren aus dem Heraion von Samos. *Scienze dell' Antichità*, 3 - 4 (1989-1990), 317 - 326.
- Brownson, C.L. 1893
C.L. Brownson. Excavations at the Heraeum of Argos. *AJA* 1893, 205 - 225.

- Bursian, C. 1854
Scavi dell'Heraion Argivo. Bull. Ist. 1854, XIII - XVII.
- Buschor, E. - v. Massow, W. 1927
Vom Amyklaion. AM LII, 1 - 85.
- Calligas, P.G. 1992
From the Amyklaion. J.M. Sanders (Ed.). **ΦΙΛΟΛΑΚΩΝ** Lakonian Studies in Honour of Hector Catling, 31 - 48. Athens.
- Carapanos, C. 1877
Dodone et ses Ruines. Paris.
- Carter, J. B. 1987
The Masks of Ortheia. AJA 91, 355 - 383.
- Caskey, J.L. - Amandry, P. 1952
Investigations at the Heraion of Argos, 1949. Hesperia XXI, 165 - 221.
- Cavanagh, W.G. - Laxton, R.R. 1984
Lead Figurines from the Menelaion and Sparta. BSA 79, 23 - 36.
- Christiansen, J. 1992
Katalog. Grækenland i geometrisk tid. Ny Carlsberg Glyptothek. København.
- Coldstream, J.N. 1968
Greek Geometric Pottery. London.
- Coldstream, J.N. 1976
Hero-cults in the Age of Homer, JHS XCVI, 8 - 17.
- Coldstream, J.N. 1977
Geometric Greece. London.
- Comstock, M. - Vermeule, C. 1971
Greek, Etruscan and Roman Bronzes in the Museum of Fine Arts. Boston. Boston.
- Courbin, P. 1955
Chronique des Fouilles de 1954, II. Argos. BCH 79, 312 - 314.
- Courbin, P. 1957
Une tombe géométrique d'Argos. BCH 81, 322 - 386.
- Courbin, P. 1963
Etudes Archéologiques. Recueil de travaux, publ. sous la direction de P. Courbin. Paris.
- Courbin, P. 1966
La Céramique Géométrique de l'Argolide. Paris
- Courbin, P. 1974
Les Tombes Géométriques d'Argolide. I (1952 - 1958). Et. Pel. VII.
- Craddock, P.T. 1976.
The Composition of the Copper Alloys used by the Greek, Etruscan and Roman Civilisations, 1. The Greeks before the Archaic Period. JAScien. 3, 93 -113.
- Croissant, F. 1992
Les Débuts de la Plastique Argienne. Polydipsion Argos, 69 -86.
- Culican, A.W. 1978
Jewellery from Sarafand and Sidon, OpAth. XII, 133 - 139.
- Daux, G. 1959
Chronique des Fouilles en 1958. Argos. BCH 83, 754 - 774.
- DeVries, K. 1974
A Grave with a Figured Fibula at Lerna, Hesperia XLIII, 80 -104.
- Desborough, V. R.d'A. 1972
The Greek Dark Ages. London.
- Deshayes, J. 1966
Argos, les Fouilles de la Deiras. Et. Pel. IV.
- Droop, J.P. 1907
Laconia I. Excavations at Sparta 1907. BSA XIII, 1906 - 07, 109 - 136.
- Dugas, C. 1921
Le Sanctuaire d'Aléa Athena a Tegée. BCH 1921, 335 - 435.
- Dyggve, E. - Poulsen, F. - Rhomaios, K. 1934. Das Heroon von Kalydon. København.
- Fellman, B. 1984
Frühe olympische Gürtelschmuckscheiben aus Bronze. Ol. Forsch. XVI. Berlin.
- Felsch, R. - Kienast, H. 1975
Ein Heiligtum in Phokis. AAA VIII, 1 - 24.
- Felsch, R.C.S. - Kienast, H.J. - Schuler, H. 1980.
Apollon und Artemis oder Artemis und Apollon? Bericht von den Grabungen im neu entdeckten Heiligtum bei Kalapodi 1973 -1977. AA 1980, 38 - 123.
- Felsch, R.C.S. 1983,
Zur Chronologie und zum Stil geometrischer Bronzen aus Kalapodi. Renaissance, 123 - 129.
- Felsch, R.C.S. et. al. 1987
Bericht über die Grabungen der Artemis Elaphebolos und des Apollon von Hyampolis 1978 - 1982, AA 1987, 1 - 99.
- Floren, J. 1987
Die geometrische und archaische Plastik. Handbuch der Archäologie. Die griechische Plastik. Band I. München.
- Foley, A. 1988
The Argolid 800 - 600 BC. Göteborg. SIMA LXXX.
- Furtwängler, A. 1890
Die Bronzen und die übrigen kleineren Funde. Ol. IV. Die grossen Dreifüsse, 75 - 93.
- Gabelmann, H. 1965.
Studien zum frühgriechischen Löwenbild. Berlin.
- Gehrig, H. 1964
Die geometrischen Bronzen aus dem Heraion von Samos. (Diss. Hamburg).
- Hägg, R. 1974
Die Gräber der Argolis, 1. Boreas 7, 1.
- Hägg, R. 1987 a
Zur Stadtwerdung des dorischen Argos. Papenfuss, D. - Strocka, V.M. (Eds.). Palast und Hütte. (Berlin 1979). Mainz a.R. 1982, 297 - 307.
- Hägg, R. 1987 b
Gifts to the Heroes in Geometric and Archaic Greece. Gifts to Gods, 93 - 99.
- Hägg, R. 1992
Geometric Sanctuaries in the Argolid. Polydipsion Argos, 9 -23.
- Hampe, R. 1936
Frühe griechische Sagenbilder in Böotien. Athen.
- Heilmeyer, W.-D. 1969
Giessereibetriebe in Olympia. JdI 84, 6 - 28.
- Heilmeyer, W.- D. 1979
Frühe olympische Bronzefiguren. Die Tiervotiven. Ol. Forsch. XII. Berlin.
- Heilmeyer, W.-D. 1981 a
Antike Werkstättenfunde in Griechenland. AA 1981, 442 - 453.
- Heilmeyer, W.-D. 1981 b
Wagenvotive. Ol. Ber. X, 59 - 71.

- Herrmann, H.-V. 1964
Werkstätten geometrischer Plastik. Jdl 79, 17 - 71.
- Herrmann, H.-V. 1966
Die Kessel der Orientalisierenden Zeit, 1. Kesselattachen und Reliefuntersätze. Ol. Forsch. VI. Berlin.
- Herrmann, H.-V. 1982 a
Geometrische Fibeln der Tübinger Universitätssammlung. Freytag geb. Löringhof, B. von, Mannsberger, D. and Prayon, F. (Hrsg.). Praestant Interna. Festschrift für Ulrich Hausmann. Tübingen, 248 - 260.
- Herrmann, H.-W. 1982 b
Rezension Heilmeyer, W-D. 1979. BonnJb, 182, 613 - 619.
- Higgins, R. 1980
Greek and Roman Jewellery. 2nd Ed. Berkeley/Los Angeles.
- Hiller, Fr. 1979
Beobachtungen zur Form der spätgeometrischen Plastik. Jdl 94, 17 - 31.
- Himmelman-Wildschütz, N. 1964
Bemerkungen zur geometrischen Plastik. Berlin.
- Himmelman-Wildschütz, N. 1974
Geometrisches Bronzepferdchen in Bonn. AA 1974, 544 - 554.
- Himmelman, N. 1992
Archäologische Forschungen in Akademisches Museum. Bonn. Die griechisch-ägyptische Beziehungen. Bonn.
- Hölbl, G. 1979
Beziehungen der ägyptischen Kultur zu Altitalien 1 - 2. Leiden.
- Hölbl, G. 1986
Ägyptisches Kulturgut in Phönikischen und Punischen Sardinien. 1 - 2. Leiden.
- Jacobsthal, P. 1956
Greek Pins. Oxford.
- Jantzen, U. 1975
U. Jantzen. Führer durch Tiryns. Athen.
- Johansen, F. 1994
Grækenland i arkaisk tid. Katalog Ny Carlsberg Glyptotek. København.
- Johnston, A. 1990
L.H. Jeffery. Local Scripts of Archaic Greece. 2nd. Ed. Supplement 1961 - 1987, 423 - 481. Oxford.
- Karouzos, S.P. 1952
Ἀρχαϊκὰ μνημῆα τοῦ Ἐθνικοῦ Μουσείου
AÉphem. 1952 (1955), 137 - 166.
- Kelly, T. 1976
A History of Argos to 500 B.C. Minneapolis.
- Kilian, K. 1975 a
Fibeln in Thessalien von der mykenischen bis zur archaischen Zeit. PBF XIV, 2. München. 1975.
- Kilian, K. 1975 b
Trachtzubehör der Eisenzeit zwischen Ägäis und Adria. PZ 50, 9 - 140.
- Kilian, K. 1979.
Ἀρκαδικές καί Λακωνικές ἰδιομορφίες στα χαλκὰ κοσμήματα.
Lakonikai Spoudai, 4. Praktika A. 1977. (1979), 33 - 38.
- Kilian, K. 1983
Weihungen aus Eisen und Eisenverarbeitung im Heiligtum zu Philia (Thessalien). Renaissance, 131 - 146.
- Kilian(-Dirlmeier), I. 1978
Weihungen an Eileithyia und Artemis Orthia. ZPE 31, 219 - 222.
- Kilian-Dirlmeier, I. 1985
Fremde Weihungen in griechischen Heiligtümern vom 8. bis zum Beginn des 7. Jahrhunderts v. Chr. JbZMuzMainz 32, 215 - 254.
- Kunze, E. 1952
Neue Meisterwerke griechischer Kunst aus Olympia. München.
- Kunze, E. 1967
Kleinplastik aus Bronze. Ol. Ber. VIII, 213 - 250.
- Langdon, S.H. 1984
Art, Religion and Society in the Greek Geometric Period. Bronze Anthropomorphic Votive Figurines. Diss. Indiana 1984. Ann Arbor 1985.
- Lauter, H. 1973
Zur frühklassischen Neuplanung des Heraions von Argos. AM 88, 175 - 187.
- Lerat, L. 1938
Fouilles de Delphes. Rapport préliminaire. RA 6. Serie 12, 183 - 227.
- Linders, T. 1972
Studies in the Treasury Records of Artemis Brauronia found in Athens. Stockholm.
- Maass, M. 1977
Kretische Votivdreifüsse. AM 92, 33 - 59.
- Maass M. 1981
Die geometrischen Dreifüsse von Olympia. AntK. 24, 6 - 20.
- Marinatos, N - Hägg, R. 1993
Greek Sanctuaries. London/New York.
- Matthäus, H. 1980
Die Bronzegefäße der kretisch-mykenischen Kultur. PBF II 1. München.
- Matthäus, H. 1985.
Metallgefäße und Gefäßuntersätze der Bronzezeit, der geometrischen und archaischen Periode auf Cypern. PBF II 8. München.
- Miller, S.G. 1977
Excavations at Nemea, 1976. Hesperia 46, 1 - 26.
- Miller, S.G. 1990.
Nemea. A Guide to the Site and Museum. Berkeley - Los Angeles/ Oxford.
- Mitsopoulos - Leon, V. 1990
Lusoi. ÖJh 60. Beiblatt. Grabungen, 31 - 36.
- Morgan, C. 1990
Athletes and Oracles. The Transformation of Olympia and Delphi in the Eighth Century BC. Cambridge.
- Morgan, C - Whitelaw, T. 1991
Pots and Politics: Ceramic Evidence for the Rise of the Argive State. AJA 95, 79 - 108.
- Morgan, C. 1993
The origins of pan-Hellenism. Marinatos - Hägg 1993, 18 - 44.
- Morris, S.P. 1984
The Black and White Style. Athens and Aigina in the Orientalizing Period. London.
- Munro, P. 1969
Eine Gruppe spätägyptischer Bronzespiegel. ZÄS 95, 92 - 109.

- Muscarella, O.W.
Greek and Oriental Cauldron Attachments: A Review. *Greece Between East and West*, 16 - 45.
- Nilsson, M.P. 1941
Geschichte der griechischen Religion I. *Handbuch der Altertumswissenschaft*. V, 2, 1. München.
- Onasoglou, A. 1989
Οι γεωμετρικοί ταφοί της Τραγάνας στην ανατολική Λοκρίδα
ADelt. 36 A 1981 (1989), 1 - 57.
- Paleologou, H. 1980
Un vase géométrique figuratif d'Argos.
BCH. Suppl. VI, 75 -84.
- Perdrizet, P. 1908
Monuments figurés, petits bronzes, terres-cuites, antiquités diverses. *FdD V*. Paris.
- Philipp, H. 1981
Bronzeschmuck aus Olympia. *Ol. Forsch.* XIII. Berlin.
- Polignac, F. de. 1984
La naissance de la cité grecque. Paris.
- Polignac, F. de. 1991
Convergence et compétition: aux origines des sanctuaires de souveraineté territoriale dans le Monde Grec. (Ed. Brunaux, J.-L. *Les Sanctuaires Celtiques et le Monde Méditerranéen. Actes du Colloque de Saint Riquier* (1990). Paris, 97 - 105.
- Popham, M. - Sackett, L. H. 1979
Lefkandi I: The Iron Age. London.
- Poulsen, F. - Rhoimios, K. 1927
Erster vorläufiger Bericht über die dänisch-griechischen Ausgrabungen von Kalydon. *Det kgl. Danske Videnskabernes Selskab. Historisk-filologiske Meddelelser*. XIV 3. København.
- Poulsen, F. 1951
Catalogue of the ancient Sculpture. The Ny Carlsberg Glyptothek. Copenhagen.
- Protonotariou - Deilaki, E. 1961
Χαλκοῦν γεωμετρικὸν εἰδῶλιον ἔξ Ἀσίνης.
AEphem 1953/54 III, 318 - 320.
- Protonotariou-Deilaki, E. 1984
Ἄπο τό Ἄργος τοῦ 8^{ου} καί 7^{ου} αἰ. π.Χ.
ASAtene LX (1982), 33 - 48.
- Rangabé, A. Rizo. 1855,
Ausgrabung beim Tempel der Hera unweit Argos.
- Reber, K. 1991
Untersuchungen zur handgemachten Keramik Griechenlands in der submykenischen, protogeometrischen und der geometrischen Zeit. Göteborg.
- Risberg, C. 1993
Metal working in Greek Sanctuaries. *Economics of Cult*, 33 -40.
- Roes, A. 1953
Fragments de poterie géométrique trouvés sur les citadelles d'Argos. *BCH* 77, 90 - 104.
- Rolley, C. 1969
Monuments Figurés: Les Statuettes de Bronze. *FdD V*, I.
- Rolley, C. 1973
Bronzes Géométriques et Orientaux à Delos. *BCH Suppl.* I, 491 -524.
- Rolley, C. 1977
Monuments Figurés: Les Trépieds à Cuve Cloué. *FdD V*, 3.
- Rolley, C. (et. al.) 1983 a
Bronzes grecs et orientaux. Influences et apprentissages. *BCH* 107, 111 - 130.
- Rolley, C. 1983 b
Les bronzes grecs. *Recherches récentes*. *RA* 1983, 325 - 336.
- Rolley, C. 1984
Die griechischen Bronzen. München.
- Rolley, C. (et. al.) 1986
Trépieds géométriques de bronzes. *BCH* 110, 121 - 136
- Rolley, C. 1988
Les bronzes grecs: *Recherches récentes*. *RA* 1988, 341 - 355.
- Rolley, C. 1992
Argos, Corinthe, Athènes. Identité culturelle et modes de développement (IX - VIIIe s.) *Polydipsion Argos*, 37 - 49.
- Rostoker, W. - Gebhardt, E.R. 1980
The Sanctuary of Poseidon at Isthmia: Techniques of Metal Manufacture. *Hesperia* 49, 347 - 363.
- Sakellarakis, J.A. 1988
Some Geometric and Archaic Votives from the Idaean Cave. *Cult Practice*, 173 - 193.
- Sapouna - Sakellarakis, E. 1978
Die Fibeln der griechischen Inseln. *PBF XIV* 4. München.
- Sarian, H. 1969
Terres cuites géométriques. *BCH* 93, 651 - 678
- Schefold, K. 1960
Meisterwerke griechischer Kunst. Basel.
- Schilbach, J. 1984
Eine Gruppe grosser protoarchaischer Pfendstatuetten aus Olympia. *AM* 99, 5 - 15.
- Schmaltz, B. 1980 a
Volumen und Schwerkraft in der Kunst geometrischer Zeit. *MarbWPr* 1980, p. 3 - 36.
- Schmaltz, B. 1980 b
Metallfiguren aus dem Kabirenheiligtum bei Theben. Die Statuetten aus Bronze und Blei. Das Kabirenheiligtum bei Theben. VI. Berlin.
- Schweitzer, B. 1969
Die geometrische Kunst Griechenlands. Köln.
- Simon, C. 1986
The Archaic Votive Offerings and Cults of Ionia. (Diss.) Berkeley.
- Sinn, U. 1980.
Ein Fundkomplex aus dem Artemis-Heiligtum von Lusoi im Badischen Landesmuseum. *JbKuSammlBadWürt.* 17, 25 - 40.
- Snodgrass, A.M. 1964
Early Greek Armour and Weapons from the end of the Bronze Age to 600 B.C. Edinburgh.
- Snodgrass, A.M. 1967.
Arms and Armour of the Greeks. New York.
- Stubbe-Østergaard, J. 1991
Terracotta Horses and Horsemen of Archaic Boiotia. *Acta Hyperborea* 3, 111 - 189.
- Themelis, P.G. 1969
Sanctuary of Poseidon at Akovitika near Kalamata, *AAA* II, 352 - 357.
- Tomlinson, R. 1992
Perachora. O. Revardin - B. Grange (Edts.) *Entretiens sur L'Antiquité Classique XXXVIII. Le Sanctuaire Grec. VIII*, 321 -351.

- Touloupa, E. 1972.
Bronzebleche von der Akropolis in Athen.
Gehämmerte geometrische Dreifüsse. *AM* 87, 57 - 76.
- Tracy, S. V. 1986
An early inscribed gold ring from the Argolid, *JHS* CVI, 196.
- Trolle, S. 1979
An Egyptian Head from Camiros. *ActArch* 49, 139 - 150.
- Vogt, I. 1991
Studien zur Pferd und Reiter in der frühgriechischen Kunst. (Diss.) Bonn.
- Vollgraff, W. 1956
Le Sanctuarie d'Apollon Pythéen a Argos. *Et. Pel.* I.
- Voyatzis, M. E. 1990
The Early Sanctuary of Athena Alea at Tegea. Göteborg.
- Wace, A.J.B. 1953
Mycenae 1939 - 1952. Part II. The Perseia Fountain House, 5. History, p. 29.
- Weber, M. 1967
Eine arkadisch-geometrische Bronze-gruppe. *Städeltj* I, 7 - 18.
- Weber, M. 1971
Die geometrischen Dreifusskessel. *AM* 86, 13 - 30.
- Weber, M. 1974
Zu frühen attischen Gerätfiguren. *AM* 89, 27 - 46.
- Whitley, J. 1988
Early States and Hero Cults: A Re-Appraisal. *JHS* CVIII, 186 -192.
- Wiesner, J. 1968.
Fahren und Reiten. *Arch. Hom.* F
- Woodhead, A.G. 1953
Mycenae 1939 - 1952 Part II, 4. The Boundary Stone from the Perseia Fountain House. *BSA* XLVIII, 27 - 29.
- Wright, J.C. 1982,
The Old Temple Terrace at the Argive Heraeum and the Early Cult of Hera in the Argolid. *JHS* CII, 186 - 201.
- Zazoff, P. 1969
Zur geometrischen Glyptik. P. Zazoff (Ed.) *Opus Nobile. Festschrift U. Jantzen*, 181 - 187. Wiesbaden.
- Zazoff, P. 1983
Die antiken Gemmen. *Handbuch der Archäologie.* München.
- Zimmer, G. 1990.
Griechische Bronzewerkstätten. Zur Technologieentwicklung eines antiken Kunsthandwerkes. Mainz.
- Abbreviations*
- AH.
Waldstein, C. The Argive Heraeum. I - II. 1902 - 1905. Boston/New York.
- AO.
Dawkins, R.M. The Sanctuary of Artemis Orthia at Sparta. *JHS. Supplementary Paper*, 5. 1929.
- Arch. Hom.
Matz, F. - Buchholz, H.-G. (Hrsg.) *Archaeologia Homerica.* I -IV. 1968 - . Göttingen.
- Athens NM.
The National Museum of Athens.
- Blinkenberg.
Blinkenberg Chr. *Les Fibules Grecques et Orientales.* Det Kgl. Danske Videnskabskabernes Selskab. *Historisk - filologiske Meddelelser* XIII, 1. (Lindiaka V). København. 1926.
- Corinth
Corinth. Results of Excavations conducted by the American School of Classical Studies at Athens. I - 1932 - Princeton.
- Cult Practice.
Hägg, R. - Marinatos, N. - Nordquist, G.C. (Eds.). *Early Greek Cult Practice.* Stockholm 1988.
- Delos.
Exploration Archéologique de Délos. Ecole Française d'Athènes. I - 1909- Paris.
- Economics of Cult.
Linders, T. - Alroth, B. (Eds.) *Economics of Cult in the Ancient World.* (Uppsala 1990). Uppsala 1993. *Boreas* 21.
- Et.Pel.
Etudes Péloponnesiennes I - 1956 -. Paris.
- FdD
Fouilles de Delphes. I - 1908 -. Paris.
- Gifts to Gods.
Linders, T. - Nordquist, G. (Eds.). *Gifts to the Gods.* (Uppsala 1985). Uppsala 1987. *Boreas* 15.
- Greece between East and West.
Kopcke, G. - Tokumara, I. (Eds.). *Greece Between East and West. 10th - 8th Centuries BC.* (New York. 1990). Mainz a.R. 1993.
- IS I.
Strøm, I. The Early Sanctuary of the Argive Heraion and Its External Relations (8th - Early 6th Cent. BC), *The Monumental Architecture.* *ActArch.* 59, 1988 (1989), 173 - 203.
- IS II.
Strøm, I. Evidence from the Sanctuaries. *Greece Between East and West*, 46 - 60.
- IS III.
Strøm, I. Obeloi of Pre- and Proto-Monetary Value in the Greek Sanctuaries. *Economics of Cult*, 41 - 51.
- Isthmia.
Isthmia Excavations by the University of Chicago under the Auspices of the American School of Classical Studies at Athens. I - . 1971 - .Princeton.
- K-D. Anhänger.
Kilian-Dirlmeier, I. Anhänger in Griechenland von der mykenischen bis zur spätgeometrischen Zeit. *PBF* XI, 2. München. 1979.
- K-D. Nadeln.
Kilian-Dirlmeier, I. Nadeln der frühhelladischen bis archaischen Zeit von der Peloponnes. *PBF* XIII, 8. München. 1984.
- Kerameikos
Kerameikos. *Ergebnisse der Ausgrabungen* I - 1939 - . Berlin.
- Lindos I.
Blinkenberg, Chr. *Lindos. Fouilles de l'Acropole* 1902 - 1914, I. Berlin 1931.
- Maass.
Maass M. *Die geometrischen Dreifüsse von Olympia.* *Ol. Forsch.* X. Berlin. 1978.
- OI.
E. Curtius - F. Adler. *Olympia. Die Ergebnisse der von dem Deutschen Reich veranstalteten Ausgrabung.* I - IV. 1890 -1897.

- PBF.
Prähistorische Bronzefunde I - 1969 - . -
München.
- Perachora I.
Payne, H. Perachora: The Sanctuaries of
Hera Akraia and Limenia, I. Oxford 1940.
- Polydipsion Argos.
M. Piérart (Ed.). Polydipsion Argos. Argos
de la fin des palais mycéniens á la constitu-
tion de l'Etat classique. (Fribourg
1987). BCH Supplement. XXII. Fri-
bourg/Paris 1992.
- Prosymna.
Blegen, C.W. Prosymna. The Helladic Set-
tlement Preceding the Argive Heraeum.
London 1937.
- Renaissance.
Hägg, R. The Greek Renaissance of the
Eighth Century BC: Tradition and Innova-
tion. (Athens 1981). Stockholm. 1983.
- Thera II.
Hiller von Gaertringen, F. Frhr. Thera.
Untersuchungen, Vermessungen und Aus-
grabungen in den Jahren 1895 - 1902. II.
Dragendorff, H. Theraische Gräber. Ber-
lin. 1903.
- Tiryns I.
Frickenhaus, A.- Müller, W.- Oelmann, F.
Tiryns. Die Ergebnisse der Ausgrabungen
des Instituts. Deutsches Archäologisches
Institut. Athen. Band I. 1912.
- Vitsa.
Bokotopoulou, I. Βίτσα I -III. 1986. Athen.
- Willemsen.
Willemsen, F. Dreifusskessel von Olympia.
Ol. Forsch. III. Berlin. 1957.
- Zimmermann.
Zimmermann, J.-L. Les Chevaux de
Bronze dans L'Art Géométrique Grecque.
Mainz/Génève. 1989.

Acknowledgements:

An earlier version of this article forms part of my Ph.D. thesis, *Buried Virtues. Death Rituals in Kerameikos, Athens, 700-400 B.C.*, Copenhagen 1993.

I would like to take this opportunity to thank warmly my supervisor Annette Rathje for constant support across all borders while I was writing my thesis. I also thank cordially Henrik Jacobsen for the laborious undertaking of helping me to use SPSS PC+, Bengt Petterson for his patient redrawing of my figures and valuable suggestions. The present article also profited greatly from the criticism applied to my earlier manuscript by Lone Wriedt Sørensen, Berit Wells, Mogens Herman Hansen and Anthony Snodgrass - but of course no one except myself should be held responsible for the result.

I also heartily thank the Faculty of Classics in Cambridge for housing me as a visiting scholar for half a year and the Danish Research Academy for financing this stay.

I owe a very special thanks to *Novo Nordisk Fonden* for having financed my participation in conferences and the re-drawing of my figures and also to the State Research Council for the Humanities for financing the English revision of this article. And I thank Peter Crabb for having revised my English.

However, I am unable to describe the gratitude I feel towards Anders not only for his constant readiness to discuss, criticize and furnish ideas on this article, but also to take over so many of those roles which I often failed to fulfil.