

Note

Concentrational Agriculture: Types, Functions, and Derivation

Sofus Christiansen

Concentrational agriculture, defined as types of agriculture based on local concentration of plant nutrients, encompasses two main types: shifting cultivation and infield-outfield systems. They may ecologically be characterised by their mode of concentration: either by a vertical or a horizontal transfer ('pumping') of nutrients, respectively. The use of the general term 'concentrational agriculture' for the two forms is advocated by demonstrating that functional substitution of one by the other is possible, and by showing that the one type theoretically can be derived from the other. Historically, infield-outfield systems are supposed to be developed from some form of shifting cultivation.

Sofus Christiansen: Institute of Geography, University of Copenhagen, Øster Voldgade 10, 1350 Copenhagen K., Denmark.

Constraints for Plant Growth

Fundamentally, all kinds of cultivation must address two major issues:

- suitable plants must be selected and their propagation and defense be secured
- the chosen plants must be supplied with plant nutrients (and possibly also with water)

The first point literally compares to the installation of productive machinery as in a factory; the second one to the delivery of raw materials for the production.

In spite of the ubiquity in the soil of nearly all plant nutrients, concentration of plant nutrients is used in practically all types of agriculture to promote growth - at the same time increasing yields per area-unit and per work-hour.

Similar effects are observable when soil water is regulated as in irrigated agriculture. However, for irrigational

agriculture the concentration-practices differ so widely from those of concentrating nutrients that they shall not be dealt with here.

Emphasising the supply of nutrients two main classes of world agriculture can be distinguished according to their operative principles:

- agriculture with *local concentration* of plant nutrients and
- agriculture with *import/global concentration* of plant nutrients.

In both classes the principle of *crop rotation* may be additionally applied. Often also a principle of *nutrient conservation* is operative, whereby nutrients are 'fixed' by mulching, returned to the top soil by ploughing etc.

Local concentration should here be understood as an accumulation of plant nutrients within the confines of a single agricultural unit or local area. In contrast, global concentration refers to situations whereby nutrients are adducted from outside, even remote places.

Though based on the inputs of nutrients (and accessorially of water), the division, recently used by Christiansen (1992) and probably first suggested by Steensby (1908-10), reflects a meaningful distinction. In practical terms it largely corresponds to the two types 'subsistence agriculture' and 'commercialised agriculture', but has the added advantage of referring to an ecologically significant feature: self-sustained or not.

While import-based agriculture in general tends to use internationally uniform techniques, that of local concentration shows a wide variation. Yet, two main forms are distinguishable by their mode of operation:

- shifting cultivation (with or without the use of fire)
- infield-outfield systems (with or without animals)

In the following the two types of agriculture mentioned will be characterized for comparison, and their possible genetic relationship clarified in an attempt to justify the use of the term 'concentrational agriculture' to cover both forms.

Shifting Cultivation

Usually shifting cultivation is defined as a type of agriculture that, for the maintenance of fertility, uses *periodic*

fallowing of a duration exceeding that of cropping. A parallel definition, related to the entire utilised area, would be: type of agriculture by which the fallow areas exceed those cropped at a given time (e.g. Ruthenberg, 1971). The stage of vegetational development achieved at the end of the fallow-period is a further characteristic of the system: accordingly it can more precisely be described as a forest-, bush- or grass-fallow system. For a specific area, duration and development of the fallow correlate almost directly with the level of fertility regeneration. Hence the system may properly be characterised either by the *period between sequential harvests of the same area* or - which is the same - for an area by the time to regain its fertility by fallowing. This translates into a *concentration over time* of plant nutrients for a given area. Forest-, bush- or grassfalls express then the relative levels of fertility at which a given agricultural system is operating in its specific area.

The rationale for the use of fallowing lies with its several combined effects:

- gaining time for weathering/decomposition of materials: By this the soil fertility of each unit of area is improved by the plant nutrient elements additionally released during the fallow period from organic or mineral decomposition and thus made available for plant growth.
- provision of storing possibilities for accumulated plant nutrients in the living fallow-vegetation. Plant nutrient elements are safely stored and protected from leaching until their later release (possibly by burning) and eventual utilisation by a crop takes place. Recycling of plant nutrients from the topsoil has been shown to be common; some trees (for instance the 'White Acacia', *Faidherbia albida*) extract nutrients also from deeper parts of the soil profile. The improvement of fertility status seems partially to stem from an increase of organic (humic) soil-components which augment the capacities for both water and nutrient retention in the soil (Sanchez 1976).
- reduction of weed growth: By natural competition openland weeds (usually infesting fields after clearance) are radically reduced in numbers as the fallow vegetation in its successional development passes on to bush- and forest associations with no or little herbal forest floor vegetation.

The use of fire for a rapid release of plant nutrients from cut-down and dried fallow vegetation has additional beneficial effects. By heating, parts of the microflora and -fauna

in the soil are exterminated and left to decompose. Also some chemical compounds are broken down releasing soluble elements, and many weeds eradicated (both those already germinated and those dormant in the seed-bank). Use of fire is, however, not always solely benevolent. So called 'dead-burning' may occur, leaving the soil almost without organic matter and many elements (such as for instance sulphur and nitrogen) volatilised. In the same way processes such as leaching, surface run-off, erosion, denitrification etc. are accelerated and may lead to severe losses.

Normally in shifting cultivation the most remarkable feature is that the net effect of all processes of gains and losses is a gain of nutrients, even when removal of the harvested plant parts is considered. Release, uptake and storing can thus be seen as a gradual concentration over time of the nutrient elements of a given area.

This leads to the important question whether shifting cultivation is sustainable or not (see e.g. FAO 1957 and Ruthenberg 1971). Will the vegetational nutrient bank - as observable from the mature fallow vegetation - be degraded after many repetitions of fallow-crop cycles, or can the fallow regenerate composition as well as volume of the original vegetation? Inevitably nutrients are lost from a given area under shifting cultivation, for instance from leaching of the ashes after burning. For sustainability these losses must be counteracted by adduction via weathering/decomposing, biological fixation of gases from the air, sedimentation etc. The viability of the system depends not only on the total amounts of matter exchanged, but rather on the rates by which gains are accumulated and losses occur. Nye & Greenland (1960) have given a classical analysis of the exchanges). Neither the rates nor their underlying processes are, however, too well known and doubtless display much local variability. Archaeological and historical evidence points, however, at the fact that given enough time for concentration, the system is sustainable over centuries.

Another often discussed question is whether or not the regeneration/increase of fertility mainly is due to a recycling of the nutrients from the top soil or it includes additional exploitation of deep soil layers. A kind of *vertical pumping* of nutrients has been documented (Nye & Greenland 1960, Sanchez 1976 etc.), but its efficiency is still open for discussions (see e.g. Breman et al. 1995).

Operation of a shifting cultivation system only demands relatively little work - nature does the most - but it requires from the user a fund of empirical knowledge of the behav-

jour of the system including recognition of the early signs of soil exhaustion. Outputs per area unit vary with inherent soil fertility, climate etc., and can, when long fallows are used, reach admirable levels. Further the system does not require draught animals, expensive implements or other capital inputs. It is the poor man's chosen cultivation in areas of much available land for cultivation; easy to run at low cost, adaptable to a great variety of environments, and with an ability to meet most levels of requirements for food supplies - at variable amounts of labour though.

Crop Rotation: Species-related Fallowing

In contrast to shifting cultivation, which works by fallowing whole fields, crop rotation functions as a kind of species-related fallowing. If a kind of crop is only resown in a field at intervals or planted in a specific pattern, time is gained for reestablishing a store of those nutrient elements in the soil, which are specifically in demand for that crop. As a consequence, agricultural systems with permanent tillage and crop rotation can be perceived as a marginal type of concentrational agriculture: shifting cultivation with partial fallowing. When nitrogen-fixating plants are included in a rotation, providing a much needed macro-nutrient from the air, the yields of permanent agriculture may approach the levels achieved by the other types of local concentration.

Infield-outfield Agriculture

Generally this type of agriculture is defined as one by which at least *two types of land* with different intensity of utilisation are *combined within one farming unit*. The infield is the most, the outfield least, intensively utilised. Clearly, such a definition covers many variations of farming systems. In a Nordic context the outfield, 'udmark', is usually little or not at all cultivated, whereas in Great Britain the outfield often has some cultivation, though of low intensity (e.g. with shifting cultivation) in relation to the permanent, more intensive cultivation of the infield (Nordic: 'indmark'). Among the many types of infield-outfield systems distinguishable, the interdependent, 'linked' or 'coupled', ones deserve extra attention. In most cases these involve a mechanism of nutrient transfer from the outfield to the infield.

The transfer may be brought about in two ways, either by humans transporting (carrying, carting...) vegetable materials from the outfield to the infield (sometimes as feed or bedding via a cowshed, stable or pen), or by animals conveying matter by grazing/browsing the outfield and depositing excreta in or near the infield. In both types of transfer the essential feature is *the transport of nutrients* from one area (the outfield) to another (the infield) to sustain or increase fertility of the latter. Infield-outfield systems of this type are thus concentrational cultivation with *concentration over area*, i.e. with an effect resembling that of an horizontal 'pumping' of plant nutrients from the outfield to the infield. Both types are using supporting areas, 'shadow areas', for their maintenance.

The effects of such a horizontal transfer have already been demonstrated (e.g. Uhlig 1961). Recently, by an experiment in 'The Hjerl Hede Open-Air Museum' in Denmark the quantities of nutrients transferred were found to be sizeable, clearly determined by the area of the outfield, and to the rates of transport and of nutrient-regeneration. Further, the effects were reinforced by a mechanism for conservation of the nutrients by absorption in a heather-bedding for the animals (Christiansen 1995, unpublished). Uhlig (1961) observed the same effect, which by the continuous removal of turf sods in large parts of NW European heathlands seems to have resulted in the formation of the so-called 'plaggen'-soils.

From the description of functions above it seems justified to see shifting cultivation and infield-outfield farming as two different expressions for the same agricultural strategy: that of local concentration or transfer. The effects of the concentrational mechanism in an infield-outfield system resemble those reported above for shifting cultivation. We re-find the same improvement of fertility in a long-time fallow as in the manured infield; similarly, the nutrient-empty, depleted soil under the mature fallow has its counterfeit in the balanced exhaustion of the outfield after long use. Even the nutrient conservation achieved by using turves described above finds a counterfeit in shifting cultivation where cut fallow vegetation often is used as mulch or for making compost to obtain a similar effect. Other derived effects of the infield-outfield functions are also very similar to those of shifting cultivation: gains such as higher yields per hectare and less cost of labour per kilogramme harvested are similarly observed. The two systems also have in common the fact that the marginal gains from extending the fallow period/expanding the outfield area are

diminishing at higher levels of inputs. Possibilities for a stable development of land use also seem quite evidently to depend on allowing each of the systems sufficient use of supporting areas to accumulate enough nutrients for sustainability. Differently expressed: area/time combinations should allow a given yield to be achieved, a feature which is elaborated below.

Even if the two system convincingly behave in much the same way, it remains to demonstrate that they are of 'the same nature'. This translates into two demands:

- that any given example of one type of system functionally can be translated into one of the other type (proof of congruity).
- that 'missing links' genetically connect the two types, one to the other, indicating a common origin.

Shifting Cultivation and Infield-Outfield Systems: Interchangeable and Genetically related?

The gains from following in a shifting cultivation system may be substituted by similar gains from outfield-infield transfer in an equivalent infield-outfield system. An example may amply demonstrate this.

If a shifting cultivation system is run for example with five years fallow for each year of cultivation, its spatial arrangement may take the shapes shown (fig.1a) among the existing infinite possibilities. Now, if for some reason (nearness to settlement, extraordinary soil quality..) a specific area has been chosen for permanent cultivation, the threatening, inevitable soil exhaustion must be counteracted by the transfer of plant nutrients to the continuously cropped field. This can be achieved by cutting vegetation from the oldest fallow parcel, transport it to the field, and treat it as if it were fallow vegetation grown on the parcel. Since the areas are equivalent and the duration of the two reconstitutive periods is the same in the two cases (see fig.1b), the nutrient adduction must be expected to be - at least theoretically - the same. Which means that for any shifting cultivation system of a given intensity (expressed by the ratio of annually harvested area to the totally cultivated) an infield-outfield system of identical total area and of identical performance can be found.

In fig.2 the possibilities for substitution of area by time to reach a given level of fertility/contents of plant nutrients are shown. In infield-outfield systems combinations of

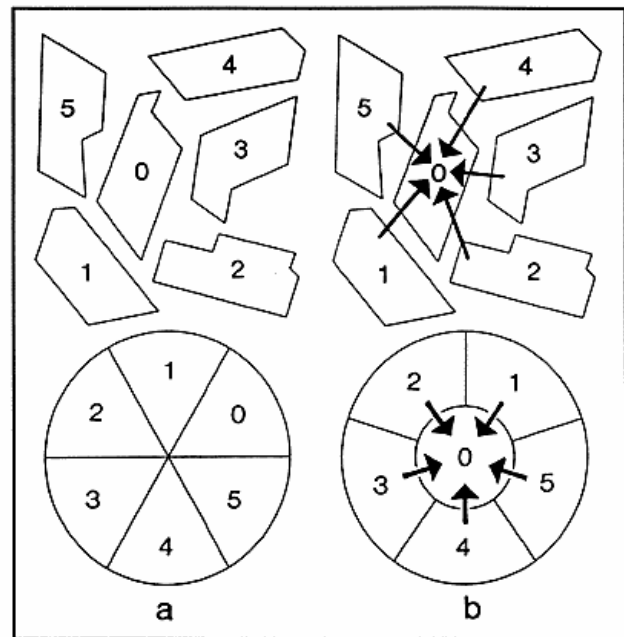

Figure 1: Fig.1 a and b: a) Configuration of two shifting cultivation systems with one year of cultivation (marked '0') followed by five years of fallow (1-5). b) Two infield-outfield systems derived from a) with equivalent ratio cultivated/fallow area and nutrient 'capture' to show the functional relatedness between shifting cultivation and infield-outfield systems.

large areas with little time for regeneration are normally found; shifting cultivation systems are characterised by the use of much time and relatively smaller areas. But - as shown by an inserted plane of equal level of nutrient accumulation - both systems can be illustrated in one figure. It is salient to note that the substitution area/time is normally not proportional, and that optimal combinations can be found for any given system.

Whereas fig.2 may represent conditions where a woody fallow vegetation is developed, fig.3 shows situations with grassy/herbal fallows. They can be caused by frequent fires or grazing. At the lower fertility levels achieved with grass-fallows, more area/time is necessary for a given yield, but still the possibilities for substitution of any shifting cultivation system with a comparable infield-outfield systems are found.

From figs 2 and 3, which differ mainly by the maximum levels of fertility achievable over time, it can be deduced that the cost of transport/transfer of nutrients is decisive when choosing one system or the other. It can also be concluded that if the fertility level of a specific area exceeding

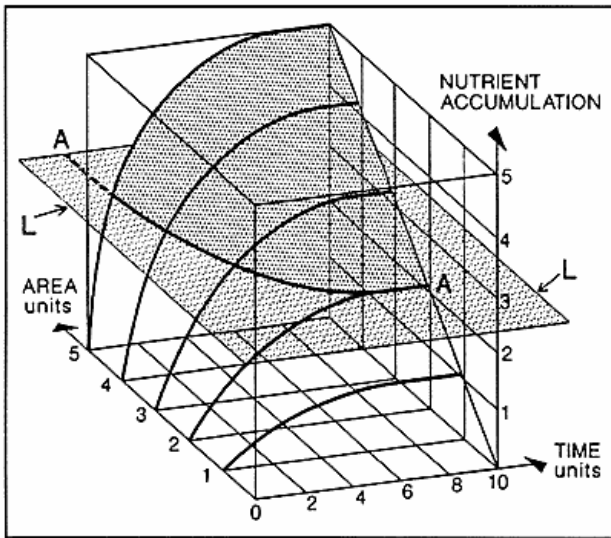

Figure 2: Area-time combinations to achieve various levels of nutrient accumulation. The plane marked 'L' exemplifies a given level, the area-time combinations of which are shown by the curve A-A. The figure shows following effects as with woody fallow vegetation.

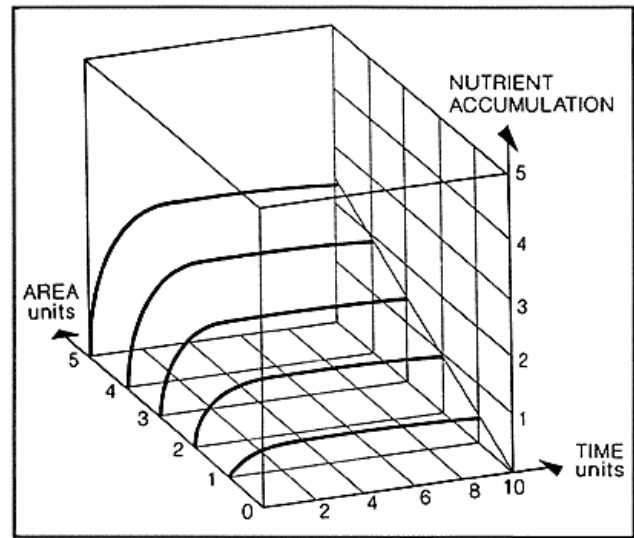

Figure 3: As for fig.2, but shown with lower nutrient concentration levels, as with grass-fallows or in weaker ecological environments.

that reached by mature fallow development is desired, such a possibility is only offered by choosing an infield-outfield system, and only when transport losses are smaller than gains.

The practical interchangeability between the two types of agricultural systems, expressed by their mutual functional substitutability, appears from the arguments above to be verifiable for shifting cultivation to infield-outfield systems if these involve a direct transfer of vegetable matter. It also applies, but involves more intricate processes, when plant nutrients are transferred via ruminants and thus chemically changed: the manure contains nitrogen and phosphorus at a higher concentration than in the feed ingested, which has a positive effect on the toil of transporting. Different development of microflora and -fauna, for example, may also distort the otherwise similar functions of the two systems. Still, substitutions leading to same results are identifiable, if both systems are operated within the limits found for normal fertility regeneration, conditioned by soil type, climate, vegetation and non-destructive utilisation. The effectual interchangeability between time and area as parameters for concentration being demonstrated, the use of agriculture with local concentration as a common term for the two systems seems meaningful.

Possible Historical Links between Systems

It may be argued that although infield-outfield systems may theoretically be derived from shifting cultivation systems, these systems may have quite a different origin in the real world. Fortunately, Allan (1967) describes a chitemene-system used by the Bemba of Zambia, East Africa. The system is at the same time describable as a type of shifting cultivation and infield-outfield systems. It can be interpreted as shifting cultivation because it uses long fallows, but the fallow growth is not burned where cut, but instead dragged to a selected area, an infield, where the whole vegetational mass is burned and the ashes used for fertilising. This example comes close to the 'missing link' looked for. Allan's observations of vegetational transfer of plant nutrients by human efforts have been confirmed also by later research (e.g. Strømgaard 1985).

However, the major part of infield-outfield systems uses the outfields for livestock keeping, a practice that may well stem from an original shifting cultivation system. The fallows of these often offer opportunities for browsing or grazing animals. If young animals (e.g. ruminants) serving as food security are kept captive in pens during nights, their dung may have proven its potential as a means for improving soil fertility. From that discovery the next stage

could easily have been the deliberate use of manure for fast recovery of the fallows. In fact evidence for the use of manure for fertilization exists already from palaeolithicum (4000 BC) in Switzerland (Troels-Smith 1984) as well as from many finds in Asia, e.g. from Jericho, 6000 BC.

Both types of nutrient concentration, over time and over area, seem thus to have been associated with agriculture from its very early beginning and with early practical connections.

Summary Remarks

The relationship between shifting cultivation and infield-outfield systems has now, hopefully, been convincingly demonstrated to be functionally related, and adequately to be termed 'concentrational agriculture'. Both express agricultural systems that use supporting areas. It remains to note that the two forms dealt with here represent very 'clean', distinct types. In the real world there are many mixed forms, where the use of fallow and of nutrient support from other areas are combined and where also crop rotation, including nitrogen fixation by leguminous crops, is applied. Some of the most sophisticated forms of ecologically sustainable and highly performing agricultural systems known fall within this group of agriculture based on locally managed supplies of nutrients, sometimes even including water regulation.

References

- Allan, W. (1967): *The African Husbandman*, chap. VI. Oliver & Boyd. London.
- Breman, H. & Kessler, J.-J. (1995): *Woody plants in agro-ecosystems of semi-arid regions*. Springer-verlag. Berlin
- Christiansen, S. (1992): *A New Attempt at an Ecological Classification of Land Utilization Systems*. *Geografisk Tidsskrift* 92: 54-60. Copenhagen.
- Christiansen, S. (1995): *Flows of matter in classical Danish heathland farming*. Unpublished manuscript.
- FAO (1954): *Opening address by Lord Boyd-Orr*. Rome.
- Nye, P.H. & Greenland, D.J. (1957): *The soil under shifting cultivation*. Techn. Comm. No. 51. Commonwealth Agric. Bureau. Harpenden.
- Ruthenberg, H. (1971): *Farming systems in the tropics*. Chap. 4. Clarendon. Oxford.
- Sanchez, P.A. (1976): *Properties and management of soils in the tropics*. Chap. 10. John Wiley & Sons. New York.
- Steensby, H.P. (1908-10): *Nogle etnografiske iagttagelser fra en rejse i Algier og Tunis 1908*. *Geografisk Tidsskrift* XIX-XX. Copenhagen.
- Strømgaard, P. (1985): *The Infield-Outfield System among the Bemba*. *Tools & Tillage* V, 2: 67-84. Copenhagen.
- Troels-Smith, J. (1984): *Stall-Feeding and Field-Manuring in Switzerland about 6000 Years ago*. *Tools & Tillage* V, 1: 13-25. Copenhagen.
- Uhlig, H. (1961): *Old hamlets with infield and outfield systems in western and central Europe*. *Geogr. Annaler*: 285-312.

could easily have been the deliberate use of manure for fast recovery of the fallows. In fact evidence for the use of manure for fertilization exists already from palaeolithicum (4000 BC) in Switzerland (Troels-Smith 1984) as well as from many finds in Asia, e.g. from Jericho, 6000 BC.

Both types of nutrient concentration, over time and over area, seem thus to have been associated with agriculture from its very early beginning and with early practical connections.

Summary Remarks

The relationship between shifting cultivation and infield-outfield systems has now, hopefully, been convincingly demonstrated to be functionally related, and adequately to be termed 'concentrational agriculture'. Both express agricultural systems that use supporting areas. It remains to note that the two forms dealt with here represent very 'clean', distinct types. In the real world there are many mixed forms, where the use of fallow and of nutrient support from other areas are combined and where also crop rotation, including nitrogen fixation by leguminous crops, is applied. Some of the most sophisticated forms of ecologically sustainable and highly performing agricultural systems known fall within this group of agriculture based on locally managed supplies of nutrients, sometimes even including water regulation.

References

- Allan, W. (1967):* The African Husbandman, chap. VI. Oliver & Boyd. London.
- Breman, H. & Kessler, J.-J. (1995):* Woody plants in agroecosystems of semi-arid regions. Springer-verlag. Berlin
- Christiansen, S. (1992):* A New Attempt at an Ecological Classification of Land Utilization Systems. Geografisk Tidsskrift 92: 54-60. Copenhagen.
- Christiansen, S. (1995):* Flows of matter in classical Danish heathland farming. Unpublished manuscript.
- FAO (1954):* Opening address by Lord Boyd-Orr. Rome.
- Nye, P.H. & Greenland, D.J. (1957):* The soil under shifting cultivation. Techn. Comm. No. 51. Commonwealth Agric. Bureau. Harpenden.
- Ruthenberg, H. (1971):* Farming systems in the tropics. Chap.4. Clarendon. Oxford.
- Sanchez, P.A. (1976):* Properties and management of soils in the tropics. Chap. 10. John Wiley & Sons. New York.
- Steensby, H.P. (1908-10):* Nogle etnografiske iagttagelser fra en rejse i Algier og Tunis 1908. Geografisk Tidsskrift XIX-XX. Copenhagen.
- Strømgaard, P. (1985):* The Infield-Outfield System among the Bemba. Tools & Tillage V, 2: 67-84. Copenhagen.
- Troels-Smith, J. (1984):* Stall-Feeding and Field-Manuring in Switzerland about 6000 Years ago. Tools & Tillage V, 1: 13-25. Copenhagen.
- Uhlig, H. (1961):* Old hamlets with infield and outfield systems in western and central Europe. Geogr. Annaler: 285-312.