

Archaeological Textiles Newsletter

ATN is a twice yearly journal published by the Society Friends of ATN, hosted by DNRF CTR.

Editorial Board:

Ulla Mannering
Eva B. Andersson Strand
Margarita Gleba
Carol A. Christiansen

The scientific committee:

John Peter Wild, UK
Lise Bender Jørgensen, Norway
Elisabeth Wincott Heckett, Ireland
Johanna Banck-Burgess, Germany
Ad hoc members

Layout:

Marianne Bloch Hansen
Sidsel Frisch

Print: Grafisk

University of Copenhagen

Subscription information:

To become a member of the society Friends of the Archaeological Textiles Newsletter and receive ATN, as well as for institutional subscription please visit:

www.atnfriends.com

ISSN 0169-7331

Contents

Editorial	1
<hr/>	
Articles	
<hr/>	
Curry-comb or toothed weft-beater? The serrated iron tools from the Roman Pannonia Judit Pásztókai-Szeőke	3
New textile finds from Dios and Xeron, two praesidia of the Eastern Desert of Egypt Dominique Cardon	14
New evidence and comparative study on fragments of hooded semicircular cloak found in the Eastern Desert of Egypt Dominique Cardon and Hélène Cuvigny	21
Römisches Outfit in Cuxhaven Julian Subbert	30
From stone to textile: constructing the costume of the Dama de Baza Ida Demant	37
Roman Rigid Heddles: a Survey Susan J. Foulkes	41
Female costume of the Golden Horde period from burial 93 of the Maiachnyi Bugor I cemetery in the Astrakhan region of Russia Olga Orfinskaya and Olga Lantratova	48
So simple and yet so complicated: A journey to Armenia to study a prehistoric warping method Karen-Hanne Stærmosse Nielsen	64
<hr/>	
Reviews	
<hr/>	
MEDATS 2011 Penny Walsh	71
TAG 2011 Ulla Mannering	72
NESAT 2011 Marianne Bloch Hansen, Ulla Mannering and Frances Pritchard	73
<hr/>	
Resources	
<hr/>	
Resent publications, websites, and dissertations	75
<hr/>	
News	
<hr/>	
News	77
Textile Calendar	78



Issue 52 includes several articles about Roman Period textiles and costumes, as well as on the use of various tools. Furthermore there is more news about costumes from the Golden Horde period in Russia (see also issue 48) and a report on an experimental reconstruction of an Iberian costume based on a sculpture. A new direction in textile studies is the investigation of textile imprints on Early Islamic period crucibles of Central Asia. In issue ?? the editors invited the readers to send in ethnographic travel studies, and Karen-Hanne Stærmoose Nielsen's article on her trip to Armenia is the first contribution in what we hope will become a regular feature of ATN. We invite the readers to send more of these important and entertaining essays. In this issue we have fewer reviews than usual, and we encourage the participants of the many and varied conferences and workshops dealing with topics related to textile research to report back to the ATN readers.

The Annual General Meeting of ATN for 2011 was held in on the 11th of May 2011 during the NESAT XI conference in Esslingen, Germany. We thank Johanna Banck-Burgess for welcoming and hosting the meeting. During the meeting many important issues raised by the editors were discussed. The minutes can be read below, but the essence is that the editors constantly strive to improve the academic profile of the newsletter and at the same time finding ways to economize with the increasing printing and postage costs. The discussion during the meeting has two important and major outcomes: from 2012 the newsletter will change its name to **Archaeological Textiles Review** and from 2012 the review will only be published **once a year** in the end of November. This means that in 2012 the society Friends of ATN only will publish issue 54 but in a much larger format, i.e. the usual two issues will be combined into one. We will focus more on the scientific articles, while most of the newsletter items (calendar, reviews, new publications, queries) will be posted on a rolling basis on the website, which should ensure an even faster dissemination. We hope this change not will disappoint the current subscribers/members too much, but the constantly increasing workload has made the publication of two issues per year no longer feasible.

Nevertheless, please make sure to renew your membership at the beginning of the year. Likewise the editors encourage the contributors to send their articles throughout the year to spread the editing workload. The peer review system which is necessary for the high standard of ATN requires more time

in the editorial process. The absolute deadline for contributions for 2012 will be the 1st of September. The editors

Minutes of the Friends of ATN General Meeting 2011

Present: Johanna Banck-Burgess, Nahum Ben-Yehuda, Marianne Bloch Hansen, Carol Christiansen, Ida Demant, Margarita Gleba, Annelies Goldmann, Karina Grömer, Carmen Keßler, Anne Hedeager Krag, Ulla Mannering, Sascha Mauel, Stefan Palm, Eva-Maria Pfarr, Frances Pritchard, Lise Ræder Knudsen, Maj Ringgaard, Elizabeth Wincott Heckett, Irita Žeiere, Hanna Zimmerman.

No additional proposals were sent in by the members, while three proposals were given by the editor (bullet point 7-9). Therefore the agenda was as following:

1. Ulla Mannering and Margarita Gleba opened the meeting by proposing to election a Chairperson for the meeting and Ida Demant was elected.
2. The report of 2010 activities: The website is finished and working. It is now **only** possible to subscribe to ATN online and reminders are sent out at the beginning of the year to remind the members/subscribers to renew their subscription. Back issues of 46-51 can be bought on the ATN website and in the future it will also be possible to buy older issues of ATN online. The editors are still working on the format. There is a regular number of contributions for ATN but the participants are encouraged to spread the word that contributions are welcome. Personal and topical bibliographies will be put on the ATN website rather than in the printed ATN format due to limited space and to ensure wider access. Contributors are encouraged to send in bibliographies to one of the editors.
3. The account for 2010 was not presented at the meeting, as it was not completed before the meeting. The account will be completed in June 2011, and presented on the ATN website together with the accounts for 2008 and 2009. To sum up the financial situation of Society of ATN, there is almost a balance between the income and the expenses for print and postage. Centre for Textile Research (CTR) has supported ATN substantially since it was moved to Copenhagen, and will continue to do so in the future as long as it exists as an institution. Funding was received for ATN 2011 in the amount of € 4.000 from the Nordic Board for Periodicals in the Humanities



and Social Sciences, NOP-HS. The Editors will continue to apply for external funding but a more long-term solution has to be found for the future funding of ATN. When applying for external funding many foundations requires that the publication is Open Access. This has to be considered for the future of ATN. Also there is often a requirement of minimum 200 subscribers. ATN has not reached this number at present but has c. 120 private subscribers and 55 institutional subscribers. It was noted that the website and online payment has not resulted in the loss of subscribers but has resulted in new ones. Despite this, the number of subscribers has been stable since 2007 with a slight fall in institutional subscribers due to general budget cutbacks affecting universities and museums.

4. Despite the decisions to raise the price of ATN at the ATN Annual Meeting in 2009 and 2010, this has not been done, as the editors have estimated that it has not yet been necessary due to simultaneous reductions in the printing costs. The aim is to keep the present prices (individual € 20/150 DKK, institutional € 30/250 DKK and back issues €10/75 DKK), but it might be necessary to raise them for 2012 if costs go up. A possible raise in price decided by the editors according to obtain a balanced account was put out to vote and accepted by the participants.

5. Election of member for the board for 2011 and 2012: Eva Andersson Strand, Ulla Mannering, Margarita Gleba and Carol Christiansen were willing to accept re-election as board members. Susanna Harris (University College London, UK) was proposed and approved as an additional editor of ATN as the workload is big and there is a need for help. The expertise of Susanna Harris will be much valued also as an English native speaker. As more submissions for ATN are coming in this also requires more hands.

6. Election of an auditor and 1 deputy auditor member for the current financial year: Marie-Louise Nosch and Lauritz H. Gregersen.

7. The editors proposed to change the name from Archaeological Textiles Newsletter (ATN) to Archaeological Textiles Review (ATR) in order to raise the professional profile of the publication. "Newsletter" sounds less professional and scientific valuable as also noted by the peer reviews made for the evaluation of the NOS-HS application from which ATN has received funding for 2011. The society Friends of ATN will retain its name. After a discussion it was decided to keep the current name

for 2011 and to change to ATR starting in 2012 after the change has been announced to the members in the editorial and on the website.

8. The editors also proposed to switch to a single issue per year in order to reduce the workload of the editors and because expenses of printing and postage are rising. One of the participants noted that it has always been a struggle to put out two issues a year and the website can supplement a yearly publication in regards to reviews, textile calendar etc. The change will also enable more focus on the scientific contents. While some members opposed this decision and expressed concern that many subscribers will not want to wait a year and noted that the website is not used by everybody regularly, the majority voted in favour of it. The single issue will be as large if not bigger as the two current issues together. ATN has grown in size in terms of the number of articles in recent years so the members/subscribers will not pay for less content. Electronic publication of ATN and possibility of approaching a professional agency to take over the practical side of the publishing were discussed. At present, ATN will only be published on paper.

Advertisement possibilities to attract more subscribers were also discussed but they require a large workload for the editors. The members are encouraged to inform the editors about other possibilities.

9. The editors proposed that back issues are to be made available on the website after 3 years since their publication. The editors reported that digital versions of ATN since 2008 with all the figures in colour are ready and permissions to publish on the website have been obtained from the authors. Thus, back issues from 2008 (46 and 47) will be published and accessible for free on the website in 2012. Back issues will continue to be published online with a 3 year delay. Printed back issues will still be available via the website. "Print on demand" is a possibility for ATN that the editors are currently exploring.

10. Miscellaneous: Johanna Banck-Burgess proposed that the NESAT Posters are published on the ATN website as the NESAT website is only temporary. The editors agreed in principle pending the agreement of the authors. The future of the NESAT website (www.nesat.org) was discussed and it was agreed to continue the purchase of the rights to the NESAT address.



Judit Pásztókai-Szeőket

Curry-comb or toothed weft-beater? The serrated iron tools from the Roman Pannonia

Introduction

Functional identification of tools from archaeological contexts is never an easy task for scholars of past technologies. Some basic implements have been used for a very long time, but the formal similarities of these ancient objects to present-day ethnographic items can result in the misinterpretation of their function. One of the aims of this paper is to specify the function of a certain iron implement known from Roman Pannonia. By focusing on its archaeological context and functional characteristics it is hoped that a more precise functional identification may be possible.

The tools in question are elongated rectangular iron blades 20-30 cm long, serrated with short teeth

(usually 1-2 per cm) along one of their longer edges and with an iron tang for the handle at a right or an obtuse angle in the middle of the other. Usually, at each corner of this latter edge, they have one wavy prong bent back to the blade with a ring hanging from it (Fig. 1). To date, at least 35 iron objects of this type are known among the archaeological finds from Pannonia:

1. Bátaszék, grave 56. (Péterfi 1993, 57-58 and Tab.VI. 56.3);
2. Bátaszék, grave 102. (Péterfi 1993, Tab. XIV. 102.8);
- 3-4. Balatonaliga (Henning 1987, Cat. Nr. 20);
- 5-6. County Baranya, stray finds (Müller 1982,

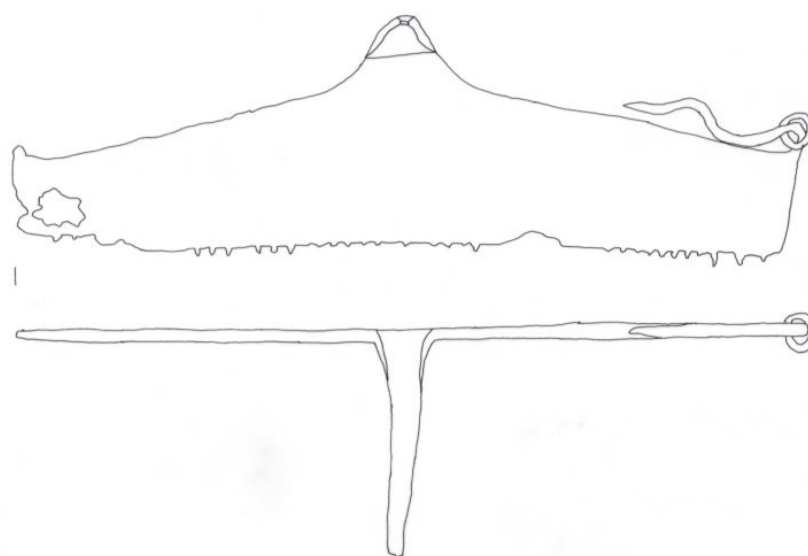

Fig. 1. Toothed iron weft-beater, Keszthely-Fenekpuszta Inv.nr. 58.21.14 (© Rupnik László).



- Cat. 2030-2031);
7. Budakalász, *burgus* (Dinnyés et al. 1986, Tab. 33.10);
 8. Intercisa, *castrum* (Henning 1987, Cat. 149);
 9. Intercisa, *canabae* (Müller 1982, Cat. 175);
 - 10-11. Hajmáskér-Seghegy (Éri et al. 1969, 99 and Tab. 18. 14; Müller 1982, Cat. 275-276; Henning 1987, Cat. 200);
 12. Keszthely-Dobogó, grave 111. (Sági 1981, 75. and Abb. 57. 22; Müller 1982, Cat. 366);
 - 13-17. Keszthely-Fenekpuszta (Müller 1982, Cat. 464-468) (1);
 - 18-21. Leányfalu, *burgus* (Müller 1982, Cat. 511-513; Dinnyés et al. 1986, 116; Henning 1987, Cat. 274);
 22. Somogyzil, grave 67. (Burger 1979, 13 and 37-8; Abb. 44; Taf. 12.3; Taf. 43);
 23. County Tolna, stray find (Henning 1987, Cat. 523);
 - 24-25. Tác, building I. (Thomas 1955, 130. Nr. 19-20. and Taf. XXXIII.1-2; Thomas 1964, Taf. CCXIII; Müller 1982, Cat. 917-918; Henning 1987, Cat. 535);
 26. Tác, sector 140/780. (Fitz-Bánki 1974, 209. vasak 1. and Fig. 20.1; Müller 1982, Cat. 919; Henning 1987, Cat. 535);
 27. Tác, sector 185/815. (Müller 1982, Cat. 920; Henning 1987, Cat. 535);
 28. Tác-Margittelep, grave 216. (unpublished);
 29. Veszprém-Ranolder street (Müller 1982, Cat. 1683);
 - 30-31. County Veszprém, stray finds (Müller 1982, Cat. 2028-2029);
 32. Tatabánya-Felső-Rét-föld (László forthcoming, Cat. 2 and Tab. I.2);
 33. Visegrád-Gizellamajor (Gróf- Gróf 1991, 89; Gróf 1992, 130);
 - 34-35. Alsóheténypuszta (unpublished).

The earliest of these items may have already been in use during the 2nd -3rd centuries AD, but from the 4th century AD onwards, there is no doubt about their use. In Pannonia, they have been found in settlements, but not in urban contexts: some come from surveys of possibly 2nd-4th century AD villa-estates (Cat. Nos. 3-4; 10-11); others from the 4th AD century inland forts (Cat. Nos. 13-17; 34-35), or from the 4th century AD fortified settlement with unclear status at Tác-Fövenypuszta (Cat. Nos. 24-27) as well as from the 4th century AD military watchtowers of Leányfalu (Cat. Nos. 18-21) and Budakalász (Cat. No. 7). Additional five items are known from 4th century AD burial contexts: four come from different rural cemeteries south of the lake Balaton (Cat. Nos. 1-2; 12

and 22) and one from the cemetery at Tác-Margittelep belonging to the above mentioned settlement in Tác-Fövenypuszta (Cat. No. 28). One additional item was found together with some agricultural tools in an iron hoard from Tatabánya-Felső-Rét-föld (Cat. No. 32). Parallels to these objects are well known from outside Pannonia with some evidence from the 2nd century AD, but the bulk dated between the 3rd-7th centuries AD (Müller 1982; Henning 1987; Gaitzsch 2005). Some morphologically identical items have also been noted from even later archaeological contexts (Nikitin 1971; Kirpichnikov 1973; 1986). They have been primarily found in the Balkan Peninsula, although occasional items are known from Italy (Rich-Chérueil 1859, 224 (under *Dens*) and 394 (under *Marra*); Gaitzsch 1980, 362. Cat. 177-180, Taf 37. 177-180), Gaul (Champion 1916, XIV. 16852; Marichal 2000, Cat. 94-100) and Asia Minor (Gaitzsch 2005, 129, Taf. 215. STR2).

Based on some morphological similarities to modern ethnographical analogies, these toothed iron tools are usually published as curry combs for horse-grooming. Differing from this generally accepted identification, an alternative possibility will be presented here.

Function: a curry-comb?

Probably the first published evidence for these toothed iron tools comes from the 19th century as a very schematized line-drawing in a widely used Latin dictionary, which depicts an object identical to those described above, originally found in a burial (Rich and Chérueil 1859, 224 (*Dens* 5.) and 394 (*Marra*)). It was published as an illustration for the *marra*, a Latin agricultural implement probably with the combined function of a rake and a hoe (the French *sarcloire*), which is often mentioned by the ancient sources (White 1967, 41-42). The author's explanation for the burial context is that the ancient Christian martyr lying in this grave had been tortured to death by the teeth of this tool (2).

According to the generally accepted and a less gruesome opinion they are believed to have been used as curry-combs for grooming animals (Kirpichnikov 1973, 85; 1986; Müller 1982, 532-4; Gaitzsch 2005, 129), although some doubts about the practicality of their sharply pointed teeth for grooming livestock have been voiced, and as a result another function as a scraper for processing hides has been suggested (Petó 1973, 72).

It was Károly Sági who, instead of searching for morphological analogies among ethnographical objects, for the first time made a suggestion based on the analysis of the archaeological contexts of the



Pannonian finds. His arguments focused on two female burials from the 4th century AD (Cat 12 and 22), each of which contained a toothed iron tool as well as other textile tools: in one case a spindle whorl, and in both cases an approximately 20 cm long iron spike with circular cross-section and one pointed end. According to Sági, the latter could be interpreted as a distaff (see below) and the toothed iron tool as a weaving comb (Sági 1973; 1981). His idea has never found general acceptance by his colleagues, since it was Sági himself who undermined the plausibility of his own arguments by including a badly chosen and incorrectly oriented illustration in his publication. While he was arguing that these iron weaving combs could have been perfectly suitable for beating the weft thread into its place *downward on a loom*, the image of the warp-weighted loom (Fig. 2) illustrating his point was inserted upside down (Sági 1973, 293-294 and fig. 66; Sági 1981, 75-76 and fig. 22). The most generally accepted theory - that the serrated tools were used as curry-combs for animal-grooming - is based on the fact that a great number of these objects were found in the Balkan Peninsula in iron hoards consisting of predominantly agricultural implements. Consequently, the scholarly interest turned towards finding morphological analogies to these toothed iron tools among the agricultural activities from later historical periods. A perfect

match was assumed to have been found among the ethnographical objects used in animal husbandry (Kirpichnikov 1973; Müller 1982, 384). These metal tools have either angular or semi-cylindrical iron blades serrated along both longer edges and either a single-, double- or triple-armed tang riveted to the blade (Fig. 3). Sometimes, the two side arms of the tang carry loose iron rings. Starting in the 12th-13th century AD such metal curry combs were used for removing dead hair, scurf and caked dirt by grooming the animal all over (Fig. 4; Müller 1982, 384; Mesterházy 1983, 155; Clark 1995, 157-165; Paládi-Kovács 2001, 643-651; Terei-Horváth 2007, 231). Based on these analogies, a chronological sequence of development was proposed for these curry-combs: the simple single-edged items from the Roman period (type I) presumably appeared as early as the 2nd century AD; by the 14th century AD they were completely replaced by the curry-combs with double-edge of a blade bent at an angle or in a semicircle (type II), which were used occasionally already during the 12th century AD. Finally, curry-combs with triple edges appeared during the 16th-17th century AD (Müller 1982, 384 and fig. 34).

An alternative suggestion: a weft-beater

Contradicting to this neatly built evolutionary typology of the metal curry-comb is an even



Fig. 2. Greek skyphos with the depiction of a warp-weighted loom (after Stærnøse-Nielsen 1999, 69).

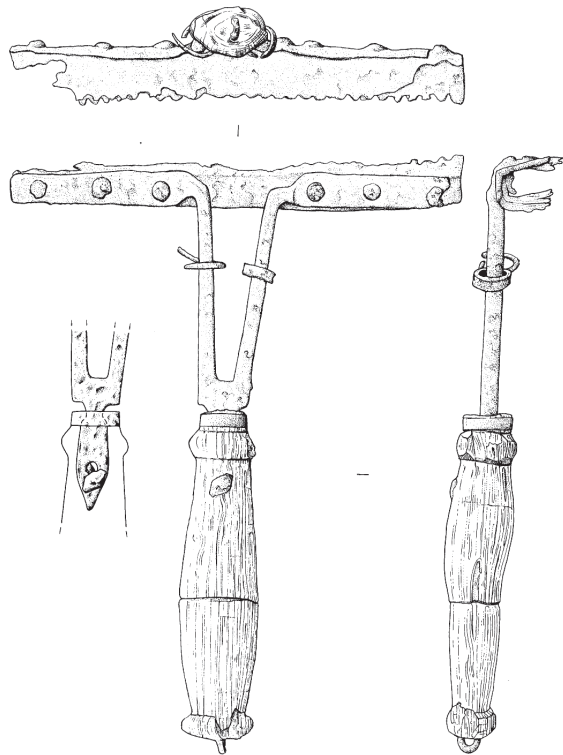

Fig. 3. Medieval curry-comb (after Clark 2004, 164, fig. 122).

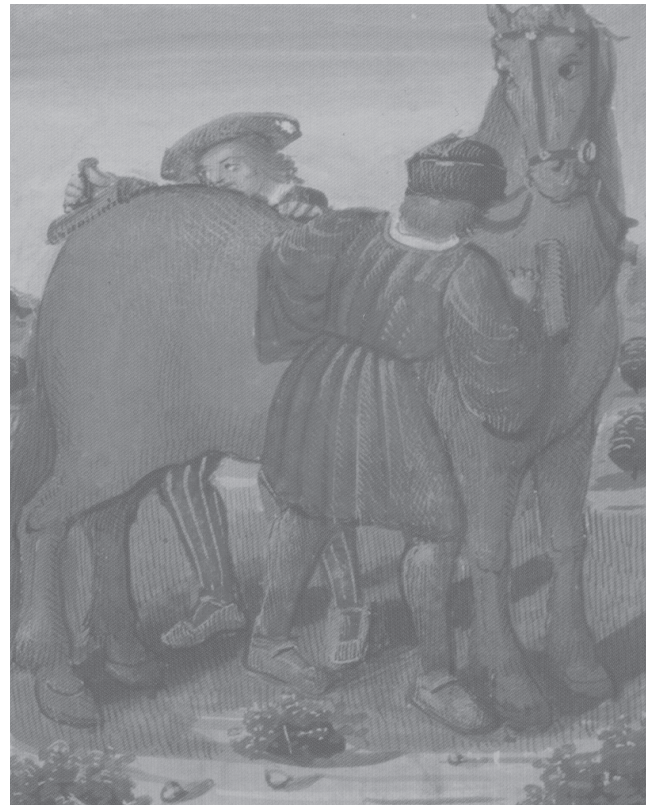

Fig. 4. Curry-comb in use on a 16th century AD depiction (Clark 2004, 157 and fig. 114).



Fig. 5. Toothed weft-beaters from Çatalcam, Turkey (© Jørgen Christian Meyer).



closer morphological parallel found in the modern ethnographical material, which provides another plausible explanation of its function. Examples almost identical to our Roman iron tool are used in the modern village Çatalcam in Turkey for beating the weft into its place while weaving kilim carpets on two-beam upright looms (Figs 5-6). Similar examples are also well known from Morocco, where they are used for weaving finer textiles on the same kind of loom, following the local traditions which might go back at least to the Roman era.

There is ample evidence for the use of a very similar toothed iron blade mounted in a wooden handle could from the first half of the 20th century in the workshops in Greece, Palestine, Turkey, Syria and even in Hungary, where the two-beam upright loom was in use for preparing the coarse fabric for tent-coverings, sacks and bags (Ébner 1931; Morton 1936, 63-64; Crowfoot 1936-37; 1941; Dalman 1937; 107-129; Domonkos 1954; 2000; Szolnoky 1954; Báldy Bellovics 1974; Broudy 1979; Lukács 2007, 69; Ciszuk

and Hammarlund 2008, 125). All these looms from modern Turkey, Morocco, Greece, Syria or Hungary could be the direct descendants of a vertical two-beam loom which is generally considered to be widely used in the entire Mediterranean area from the 1st century AD (Crowfoot 1936-37, 40; Dalman 1937, 107-129; Wilson 1938, 23-25; Crowfoot 1941, 148; Forbes 1956; Wild 2002, 11) (3).

Although several depictions of this two-beam vertical loom are known from the Roman period, none of them shows any other tool except a single-ended pin-beater (4). In contrast to this iconographic evidence, ancient literary sources mention a certain *pecten* ('comb' in Latin), a type of tool with notched teeth, which was used for beating in the weft as part of the weavers' tool-kit together with the *radius* (most probably a pin-beater) while weaving on a vertical two-beam loom (Crowfoot 1936-37; Wild 1967). Depictions of the vertical two-beam loom continue after the end of the Roman era and some of these later representations illustrate very clearly a toothed weft-beater in use. The earliest example is a miniature in the Utrecht Psalter, *Folio 84 recto*, dated to the 9th century AD (DeWald 1932, Pl. CXXXII) and its later copy in the Eadwin Psalter in Cambridge dated to the 12th century AD (Hartley and Elliot 1951, Pl. 22a; Hoffmann 1988, 242 and 243 fig. 6; Walton Rogers 1997, 1759). These images provide a profile view of the tool (Fig. 7), while a frontal view was drawn by Hrabanus Maurus in a miniature of an Italian manuscript dated to AD 1023 (Fig. 8; Ling Roth 1917, 137 and Fig. 91c and 144; Nahlik 1963, 278; Broudy 1979, Fig. 3-34; Kolchin 1989, 122). The latest found example is from a 13th century AD Byzantine manuscript, where a toothed weft-beater is probably depicted lying on the ground under the loom (Huber 1986, 233 and nr. 224; Constan 2003, 335 and fig. 1).

The Pannonian evidence

A closer look at the archaeological evidence from Pannonia allows us to further suggest that the elongated iron blades toothed along one of their longer edges and with a tang at right or obtuse angle in the middle of the other were not used for grooming animals, but rather utilized as textile tools for weaving on the vertical two-beam loom.

Five examples are known from 4th century AD burials in Pannonia: one from the inhumation burial nr. 216 at TÁC-Margittelep (Cat. No. 28), one from the inhumation grave nr. 67 at Somogyszil (Cat. No. 22), another from the cremation grave nr. 111 at Keszthely-Dobogó (Cat. No. 12), and further two items from the inhumation burials nr. 56 and 102 at BÁTASZÉK (Cat. Nos. 1-2). In each case the deceased



Fig. 6. Toothed weft-beater in use, Çatalcam, Turkey (© Jørgen Christian Meyer).

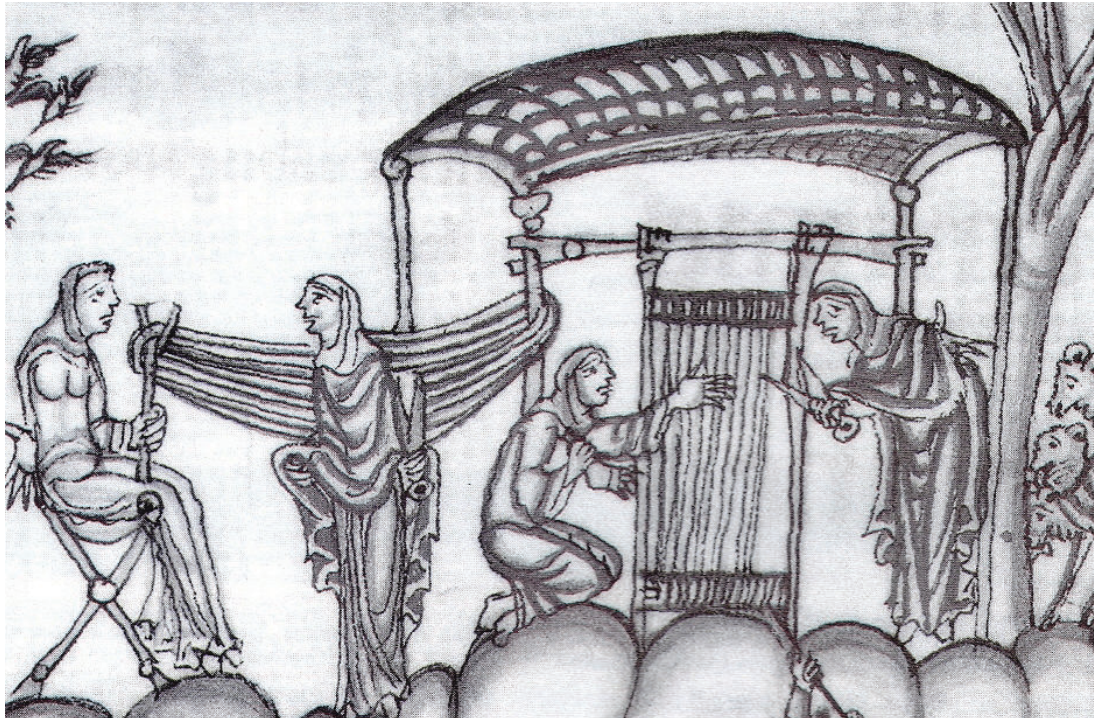

Fig. 7. Depiction of a two-beam upright loom and a toothed weft-beater in the Eadwin Psalter (after Walton Rogers 1997, 1759).



Fig. 8. Depiction of a two-beam upright loom and a toothed weft-beater by Hrabanus Maurus (Broudy 1979, Fig.3-34).



Fig. 9. Tombstone of Severa Seleuciana (after Johl 1924, 2. Abb. 2).



was a female. In two cases (Cat. Nos. 1 and 12), the toothed iron tool was found together with a spindle whorl, and in four cases (Cat. Nos. 1, 2, 12 and 28) together with a 20-30 cm long iron spike pointed at one end and a round cross-section.

As mentioned above, the function of these iron spikes, which are characteristic finds in the rural cemeteries of the 4th century AD, in the region of Pannonia south of the lake Balaton, has been interpreted in various ways: either as barbecue spits (Dombay 1957, 289; Vágó-Bóna 1976, 182; and recently Tóth 2006); or, in a possible association with textile production, as spindle shafts or distaffs (Sági 1973; 1981; Bíró 1994; Kelemen 2008; Müller 2009, 43-45). Although they could have been used for producing yarn, they are more likely to be connected to weaving than spinning.

For weaving on a vertical two-beam loom, a pointed spike, the so-called pin-beater (the Latin *radius* or the Greek κερκίς) was used to clear the shed (Crowfoot 1936-37; 44-45; Dalman 1937; Wild 1967). The weft was passed through the shed by hand as a small skein or wound around a stick, and arranged with the pin-beater before beating it in downwards with



Fig. 10. Tombstone of Genetiva from Gaul (Walton Rogers 2007, 35, fig. 2.27).

the toothed weft-beater. The beating in with the toothed weft-beater was needed to give the close weave desired, but if there was any unevenness the pin-beater could be used to pick at individual threads until they would lie close and even (Crowfoot 1941, 144-146; Ciszuk-Hammarlund 2008, 124). The pin-beaters were in use during the Roman period as documented by iconographic evidence where they are depicted side-by-side with the vertical two-beam loom (Figs 9 and 10). Usually the pin-beaters were made of wood or bone, but they could also be made of metal. Grace M. Crowfoot reported on an iron item which had been used as a pin-beater in the 1930s (Crowfoot 1936-37; 44), while literary sources from earlier periods refer to the weavers' 'iron nail' or 'iron awl', testifying that at least in Palestine a pointed iron implement was in the weavers' tool-kit as a pin-beater (Dalman 1937, 112-129).

Thus, both iron tools - the pointed pin-beater as well as the serrated weft-beater, which were found together in the Pannonian burials - could have been used for weaving on the same kind of loom, namely the vertical two-beam loom. They were not very suitable for the use with the two other types of loom known from the Roman period (for the three types of Roman looms, see Ciszuk and Hammarlund 2008 with bibliography). It is not surprising that, as grave goods, they were often deposited in the burials together with spindle whorls, while as finds from the settlements, the iron toothed weft-beaters were found in areas where textile producing activities have been documented (Thomas 1955).

Further perspectives

Looking at certain characteristics of a textile tool can give us further clues as to what the qualities of the textiles produced with their help might be. In the case of the toothed iron weft-beaters, the characteristics to be considered are the weight and width of the blade as well as the density and length of the teeth. The weight of the weft-beaters could have a crucial effect on the weft density of the fabric since high weft density demands harder/heavier beating. Unfortunately, this parameter is never provided in the publications of the archaeological finds from Pannonia. The ethnographic weft-beaters have a wide weight range: a Moroccan item weighs 125 g, while a specimen from Palestine procured for the Bankfield Museum, Halifax weighed ca. 3,6 kg (Crowfoot 1941; 144-145). It should also be kept in mind that with a higher weight and perhaps width the same result can be achieved as with a lighter and narrower tool, but the former would require a reduced number of the beat-in motion.



Archaeological publications provide more data about the width and the teeth density and length of these weft-beaters. The width ranges between 20 and 30 cm, which is not very suitable for the weaving of a patterned fabric (e.g. a kilim), where only smaller portions of different colours are prepared at the same time. For the weaving of such fabric a shorter blade is more appropriate and a wider tool might even hinder the work.

Although the density of the teeth is usually not reported in the descriptions of these objects, their scaled photographs or drawings allow to calculate that most of them had 1-2 teeth per cm. Thus, they appear to be most suitable for the preparation of fabrics with low warp counts. The length of the teeth, which is never above 5-6 mm, is also a very important characteristic in relation to the thickness of the produced fabric. Based on ethnographic data, the weft-beaters which are used for making piled carpets usually have much longer teeth; hence these short toothed tools are not suitable for such fabrics.

Thus, by considering the morphological characteristics of these toothed weft-beaters, we can exclude some less likely alternatives (piled or tapestry fabrics) from among the possible textile products.

Conclusion

Both close morphological similarities to modern parallels and Pannonian archaeological contexts strongly suggest that the original observations of Károly Sági were correct and these toothed iron tools were not used as curry-combs for grooming animals, but for producing textiles on a two-beam upright loom. This conclusion is of great importance because the iron weft-beaters (and the iron pin-beaters) provide us with a valuable clue to the presence use of a loom which in contrast to e.g. the warp-weighted loom hardly left any traces in the archaeological material of the Roman provinces.

Acknowledgements

This research was accomplished with the help of a generous Ph.D-grant co-financed by The Danish National Research Foundation's Centre for Textile Research, the University of Aarhus and by The Danish Research Council for Culture and Communication. I am also thankful for the support of the Culture Programme of the European Union in connection with the project *DressID: Clothing and Identities – New Perspectives on Textiles in the Roman Empire*. My special thanks are due to László Schilling and Loránd Olivér Kovács for their help during my research in TÁC; to Endre Tóth for the unpublished

iron weft-beaters from Alsóheténypuszta; to Lise Bender Jørgensen and Lena Hammarlund for the valuable information on the Moroccan evidence; to Jørgen Christian Meyer for the Çatalcam evidence and to Margarita Gleba for her precious help in smoothing out my English. My special gratitude also goes to my friends and colleagues in the Centre for Textile Research who supported me continuously in various ways throughout the writing process.

Notes

1. Kuzsinszky 1920, figs. 84-85: altogether 16 items of this kind are visible here.
2. Although there is no explicit reference in his text to Saint Blaise, we can suppose that Rich had the iconographical emblem of this saint in his mind (see Cardon 1999, fig. 52 and Chaloner 1957). This 4th century AD Christian martyr was believed and depicted to have been torn apart with wool combs before being beheaded, but these wool combs with their long spikes usually embedded in a wooden head with long handle are very different from the iron items serrated with short teeth. For these wool-combs and their use for torturing people in Nordic sagas, see Hoffmann 1964, 284-285.
3. It is noteworthy that several parts of this loom used in the Hungarian workshops of 1930s were called by loan-words from south Slavic languages, which is an indication of its northward spread from the Balkan Peninsula to the Carpathian Basin during the Middle Ages or later (Ébner 1931, 168).
4. Three identical two-beam looms are shown on the frieze of the Forum Transitorium in Rome (Wild 1970, 69; D'Ambra 1993). On the left of the sketched outline of a two-beam loom represented on the 3rd century AD tombstone of Severa Seleuciana from Rome a one-ended pin-beater is depicted (Fig. 7; Johl 1924, 2, Abb. 2; Wild 1970, 69). Similar loom is depicted on a 3rd century AD wall-painting in the hypogeum of the Aurelii in Rome (Wilson 1938, 21; Wild 1970, 69-70; Broudy 1979, 48), and on the tombstone of Genetiva from Gaul behind her left shoulder in profile. In the later, the deceased holds a pin-beater in her right hand and a skein of thread in her left (Fig. 8; Roche-Bernard and Ferdieri 1993, 144). The latest Roman depiction appears in a miniature of the early 5th century AD Codex Vaticanus 3225, Pict.39 (Ciszuk and Hammarlund 2008, 125).

**Bibliography**

Báldy Bellovics, F. (1974) A torba, a bácskai buvenyácok tarisznyája. *Cumania* 2, 159-64.

Bíró, M. (1994) The Unknown Goddess of Late Roman Popular Religious Belief. *Acta Archaeologica Academiae Scientiarum Hungaricae* 46, 195-229.

Broudy, E. (1979) *The Book of Looms*. New York.

Burger, A. Sz. (1979) *Das spätrömische Gräberfeld von Somogyszil*. Budapest.

Cardon, D. (1999) *La Draperie au Moyen Âge. Essor d'une Grande Industrie Européenne*. Paris.

Chaloner, W. H. (1957) The Cartwright Brothers. Their Contribution to the Wool Industry. *Wool through the Ages*.

Champion, B. (1916) Outils en fer du Musée de Saint Germain. *Revue Archeologique* 3, 211-46.

Cholakova, A. (2005) Early Byzantine hoard of iron tools and artifacts from Odartsi, near Dobrich. *Arheologija* 46, 147-158. (in Bulgarian)

Ciszuk, M. and Hammarlund, L. (2008) Roman looms – A Study of Craftsmanship and Technology in the Mons Claudianus Textile Project. In C. Alfaro and L. Karali (eds), *Vestidos, Textiles y Tintes. Estudios sobre la producción de bienes de consumo en la Antigüedad. Actas del II Symposium Internacional sobre Textiles y Tintes del Mediterráneo en el mundo antiguo (Atenas, 24 al 26 de noviembre, 2005)*, 119-133. Valencia.

Clark, J., ed. (1995) *The medieval horse and its equipment, c. 1150-c. 1450. Medieval finds from excavations in London* 5. London.

Constas, N. (2003) *Proclus of Constantinople and the Cult of the Virgin in Late Antiquity*. Leiden/Boston.

Crowfoot, G.M. (1936-37) Of the Warp-Weighted Loom. *Annual of the British School at Athens* 37, 36-47.

Crowfoot, G. M. (1941) The Vertical Loom in Palestine and Syria. *Palestine Exploration Quarterly*, 141-151.

D'Ambra, E. (1993) *Private Lives, Imperial Virtues. The frieze of the Forum Transitorium in Rome*. Princeton.

Dalman, G. (1937) *Arbeit und Sitte in Palästina. V. vol. Webstoff, Spinnen, Weben, Kleidung*.

DeWald, E. T. (1932) *The Illustrations of the Utrecht Psalter*. Princeton.

Dinnyés, I., Kővári, K., Lovag, Zs., Tetteganti, S., Topál, J. and Torma, I. (1986) *Pest megye régészeti topográfiája. A budai és szentendrei járás. Magyarország régészeti topográfiája* 7. Budapest.

Dombay, J. (1957) Későrómai temetők Baranyában. *Janus Pannonius Múzeum Évkönyve*, 181-330.

Domonkos, O. (1954) Egy tisztántúli szőrtarisznyás műhely. *Néprajzi Értesítő* 37, 192-214.

Domonkos, O. (1982) Tobakos, tobak. In Gy. Ortutay (ed.), *Magyar Néprajzi Lexikon, vol. 5*. Budapest.

Domonkos, O. (2000) Tarisznya- és pokrócszövés. in: *Szöttes textiliák mindennapi életünkben. A Hevesen 1999. augusztus 13-15-én tartott konferencia előadásai*, 119-126. Heves.

Ébner, S. (1931) A szőrtarisznyás mesterség

Dunántúlon. *Néprajzi Értesítő* 23, 165-169.

Éri, I., Kelemen, M., Németh, P., and Torma, I. (1969) *Veszprém megye régészeti topográfiája. A veszprémi járás. Magyarország régészeti topográfiája* 2. Budapest.

Fitz, J. and Bánki, Zs. (1974) Kutatások Gorsiumban 1972-ben. *Alba Regia* 13, 195-243.

Forbes, R. J. (1956) *Studies in Ancient Technology. Volume IV*. Leiden.

Gaitsch, W. (1980) *Eiserne Römische Werkzeuge. Studien zur römischen Werkzeugkunde in Italien und den nordlichen Provinzen des Imperium Romanum*. British Archaeological Reports, International Series 78 (i-ii).

Gaitsch, W. (2005) *Eisenfunde aus Pergamon: Geräte, Werkzeuge und Waffen*. Berlin.

Gróf, P. and Gróh, D. (1991) Előzetes jelentés a Visegrád-Gizellamajori római erőd feltárásáról. *Communicationes Archaeologicae Hungariae*, 85-95.

Gróf, P. (1992) Népvándorlás kori vonatkozások egy késő római erőd és temető feltárásának kapcsán. *Nyíregyházi Jósza András Múzeum évkönyve* 30-32, 129-144.

Hartley, D. and Elliot, M. M. (1951) *Life and work of the*



people of England. 11-13. Cent. London.

Henning, J. (1987) *Südosteuropa zwischen Antike und Mittelalter. Archäologische Beiträge zur Landwirtschaft des 1. Jahrtausends u.Z.* Berlin.

Hoffmann, M. (1989) Textile implements: Identification in Archaeological finds and interpretation in pictorial sources. In L. Bender Jørgensen, B. Magnus and E. Munksgaard (eds), *Archaeological Textiles. Report from the 2nd NESAT symposium. 1-4-V.1984.* Arkæologiske Skrifter, 232-246. Copenhagen.

Huber, P. (1986) *Hiob. Dulder oder Rebell? Byzantinische Miniaturen zum Buch Hiob in Patmos, Rom, Venedig, Sinai, Jerusalem und Athos.* Düsseldorf.

Johl, C. H. (1924) *Altägyptische Webestühle und Brettchenweberei in Ägypten.* Leipzig.

Kelemen, M. (2008) *Solva. Esztergom későrómai temetői. Die spätrömischen Gräberfelder von Esztergom.* Budapest.

Kirpichnikov, A. N. (1973) *Снаряжение всника и верхового коня на Руси IX-XII Вв. Arheologija SSSR Issue E1-36.* Leningrad.

Kirpichnikov, A. N. (1986) Russische Waffen des 9-15. Jahrhunderts. *Waffen- und Kostümkunde: Zeitschrift der Gesellschaft für historische Waffen- und Kostümkunde* 28(2), 85-129.

Kolchin, B. A. (ed) (1985) *Ancient Rus` Town, Castle, Village. Arheologija SSSR.* Moscow.

Kolchin, B. A. (1989) *Wooden Artefacts from Medieval Novgorod. I-II. British Archaeological Reports International Series 495 (I-II).*

László, J. (forthcoming) *Vaseszköz lelet Tatabánya – Felső-Rét-földről.*

Ling Roth, H. (1917) *Studies in Primitive Looms II. The Journal of the Royal Anthropological Institute of Great Britain and Ireland* 47, 113-150.

Lukács L. (2007) *A tisztas ipar emlékei. Céhek, céhemlékek, az iparosok hagyományai Fejér megyében és Székesfehérváron.* Székesfehérvár.

Marichal, R. (2000) *Outillage antique de Ruscino (Château-Roussillon, Pyrénées-Orientales, F).* In M.

Feugère and M. Gustin, M. (eds), *Iron, Blacksmiths and Tools. Ancient European Crafts. Acts of the Instrumentum Conference at Podsreda (Slovenia) in April 1999.* Monographs Instrumentum 12, 139-168. Montagnac.

Mesterházy, K. (1983) *Településásatás Veresegyház-Ivacson. - Siedlungsausgrabung in Veresegyház-Ivacs. Communicationes Archaeologiae Hungariae,* 133-162.

Morton, H. V. (1936) *In the Steps of St. Paul.* London.

Müller, R. (1982) *A mezőgazdasági vaseszközök fejlődése Magyarországon a késővaskortól a törökör végéig. Zalai Gyűjtemény* 19 (1-2).

Müller, R. (2009) *Guzsalyok és orsógombok Pannóniában. Zalai Múzeum* 18, 39-54.

Nahlik, A. (1963) *Ткани Новгорода. Опыт технологического анализа. Матерьялы и исследования по археологии СССР* 123, 228-313. Moscow.

Nikitin, A. V. (1971) *Работа русского кузнеца XVI-XVIII Bb. Arheologija SSSR. Issue E1-34.* Moscow.

Paládi-Kovács, A. (1982) *Tarisznya, tarisznnyás.* In Gy. Ortutay (ed.), *Magyar Néprajzi Lexikon vol. 5,* 210-12. Budapest.

Paládi-Kovács, A. (2001) *Istállózó tartásmód. Magyar Néprajz II,* 643-651. Budapest.

Pásztókai-Szeőke, J. (2010) *Curry-comb or Toothed Weft Beater? The Serrated Iron Tools from the Roman province of Pannonia.* In E. Andersson Strand, M. Gleba, U. Mannering, C. Munkholt and M. Ringgaard, M. (eds) *North European Symposium for Archaeological Textiles X. Ancient textiles series vol. 5,* 187-188. Oxford.

Péterfi, Zs. (1993) *Bátaszék-Kövesd-pusztai későrómai temető. Wosinszky Mór Múzeum Évkönyve* 18, 47-128.

Pető, M. (1973) *A pannoniai szarvasmarhatartás emlékényaga. Agrártörténeti Szemle* 15, 70-74.

Rich, A. and Chéruef, M. (1859) *Dictionnaire des antiquités romaines et grecques.* Paris.

Roche-Bernard, G. and Ferdiere, A. (1993) *Costumes et Textiles en Gaule romaine.* Paris.



- Sági, K. (1973) Római téglasír Balatonberényben és ókeresztény kapcsolatai. *Somogyi Múzeum Közleményei* 1, 289-297.
- Sági, K. (1981) *Das römische Gräberfeld von Keszthely-Dobogó*. Budapest.
- Shtereva, I. and Radeva, M. (2001) Trouvaille collective d'outils de la haute période byzantine, de Sliven. *Arheologija* 42, 79-84.
- Szolnoky, L. (1954) A bodrogközi függőleges szövőszék rekonstrukciója. *Néprajzi Értésítő* 36, 195-199.
- Terei, Gy. – Horváth, A. (2007) Az Árpád-kori Kána falu vasleletei I. *Communicationes Archaeologicae Hungariae*, 215-246.
- Thomas, E. B. (1955) Die römerzeitliche Villa von Tác-Fövenypuszta. *Acta Archaeologica Academiae Scientiarum Hungaricae* 6, 79-147.
- Thomas, E. B. (1964) *Römische Villen in Pannonien. Beiträge zur pannonischen Siedlungsgeschichte*. Budapest.
- Tóth, E. (2006) A pogány és keresztény Sopianae. (A császárkultusz-központ Pannonia Inferiorban, valamint a pogány és keresztény temetkezések elkülönítésének a lehetőségéről: a II. sírkamra). *Specimina Nova Universitatis Quinqueecclesiensis* XX, 49-96.
- Vágó, E. and Bóna, I. (1976) *Der spätrömische Südstfriedhof*. Budapest.
- Walton Rogers, P. (1997) *Textile Production at 16-22 Coppergate. The Archaeology of York. The Small Finds 17/11*. York.
- White, K. D. (1967) *Agricultural implements of the Roman world*. Cambridge.
- Wild, J. P. (1967) Two technical terms used by Roman Tapestry-weavers. *Philologus* 111.1-2, 151-5.
- Wild, J. P. (1970) *Textile Manufacture in the Northern Roman Provinces*. Cambridge.
- Wild, J. P. (2002) The Textile Industries of Roman Britain. *Britannia* 33, 1-42.
- Wilson, L. M. (1938) *The Clothing of the Ancient Romans*. Baltimore.



Dominique Cardon

New textile finds from Dios and Xeron, two *praesidia* of the Eastern Desert of Egypt

I. A long term research: textiles from the *praesidia* of the Eastern Desert of Egypt

In *ATN 50*, I described a long term program of systematic excavations in the Eastern Desert of Egypt that has provided large quantities of textile fragments, contributing to new insight into the textile technology in the ancient world during the three first centuries CE (Cardon, Bülow-Jacobsen and Cuvigny 2010). The excavations focus on small Roman fortresses (*praesidia*) built during the 1st century CE. They are scattered at a regular distance of approximately 30 km along two caravan roads leading from Koptos (now Quft) on the Nile, respectively to Myos Hormos (Quseir), and to Berenike, two important harbours on the Red Sea Coast at the beginning of the Christian era (Fig. 1). These military sites had a double function: to keep the roads safe from the desert Bedouin and to provide travellers, particularly caravans, with an adequate supply of water (Cuvigny 2003; Cuvigny forthcoming). Because of their mixed population of soldiers from different parts of the Roman Empire, accompanied by civilians from Egypt - native or of Greek origin - and also because of the extensive use of recycled textiles in these sites (Cardon, Granger-Taylor and Nowik, forthcoming), their huge rubbish heaps provide exceptionally diverse examples of textile products, some of which had been considered very rare or had been unknown until these recent discoveries.

II. Work in progress on textiles from Dios and Xeron

I now report on this year's work on textiles from the rubbish heaps of the two most recently excavated *praesidia*, both situated along the road from Koptos to Berenike: Dios, excavated by our team between 2005 and 2008; and Xeron, in which the first campaign started in december 2009, ending in January 2010.

The second campaign, started in december 2010, ended at the end of January 2011. I could not be present on the site but arrived in Egypt on January 25th with Danielle Nadal (Association Materia Viva, Toulouse) who has been cleaning and conserving textiles from the *praesidia* since 1997. We worked together on textiles from Dios and Xeron in the Store of the Supreme Council of Antiquities in Quft, in Upper Egypt, until our work was interrupted for security reasons during the first week of February and we had to hurriedly fly back to France. During that brief period of work, however, the totality of textile fragments preserved in the second of two big metal boxes containing the textiles found in Dios were sorted. They had not been examined previously. There were 63 bags containing textiles in the box. Each bag examined contained between one and fifteen different textiles. After being cleaned of earth and dust, they were placed in new bags and grouped by categories in big transparent envelopes for future study. As sorting and cleaning progressed, some particularly interesting textiles were selected and fully studied to allow a quick publication. In addition, the totality of textiles discovered in the rubbish heap and in the fort at Xeron during the second excavation campaign were examined. The contents of the 72 bags full of textiles were sorted, cleaned of earth and dust, placed in new bags and grouped by categories in big transparent envelopes for future study. As sorting and cleaning progressed, some particularly interesting textiles from Xeron were also selected to be fully studied immediately. The few days of intense work we could spend on these textiles lead us to reconsider our previous impression that, from the point of view of both the quantity and state of preservation of the textiles, these sites - and particularly Xeron - were less fruitful than the other *praesidia* already excavated by our team in the Eastern Desert.

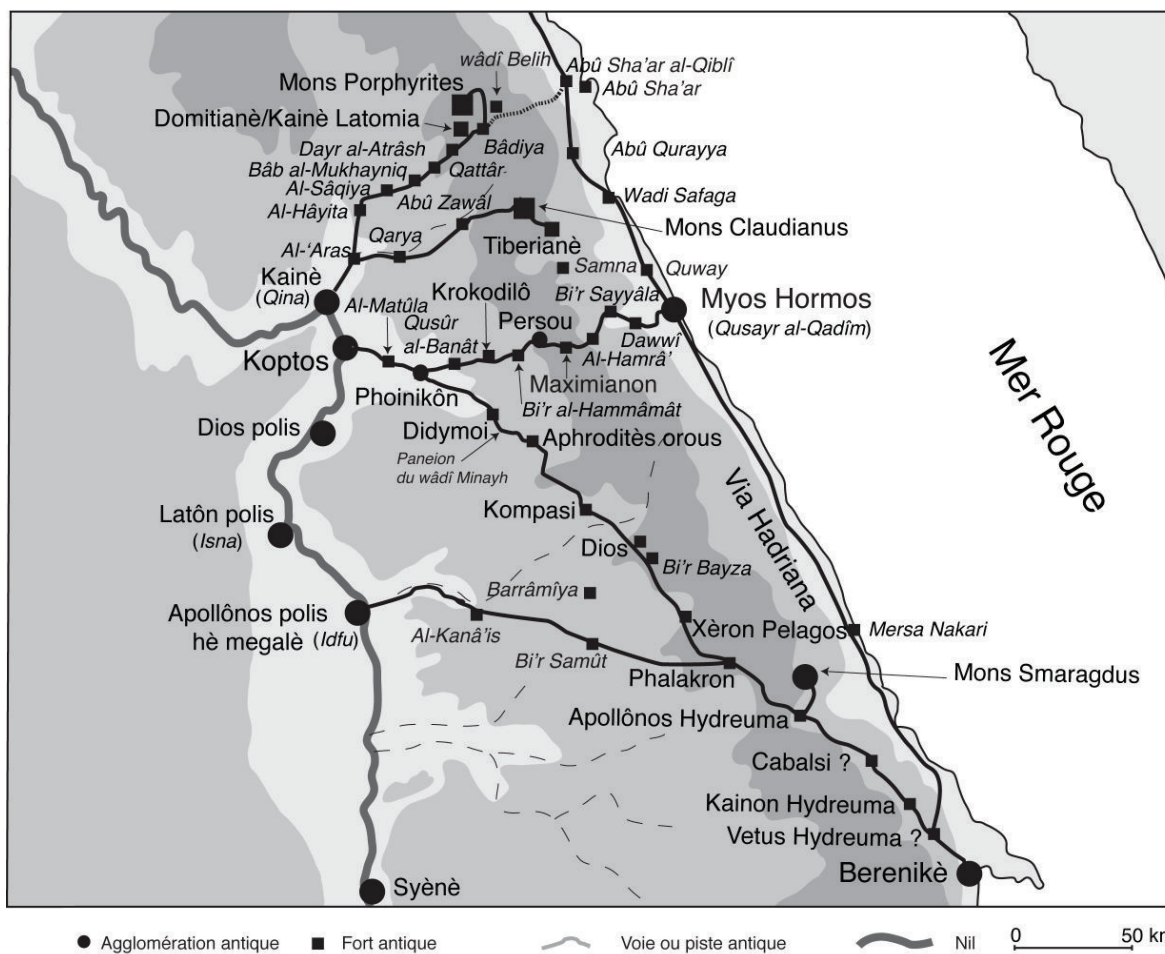
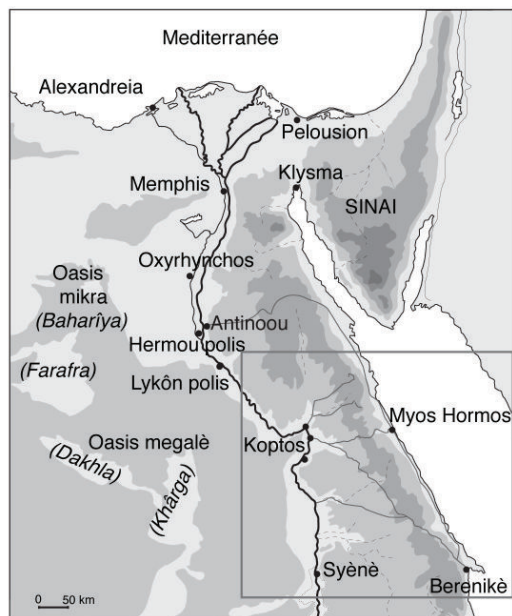

Fig. 1. Map of Egypt with locations of praesidia mentioned in the text (© J.-P. Brun, CNRS-Centre Jean Bérard).



Fig. 2. The fort of Xeron at the end of the second excavation campaign
(© J.-P. Brun, CNRS-Centre Jean Bérard).

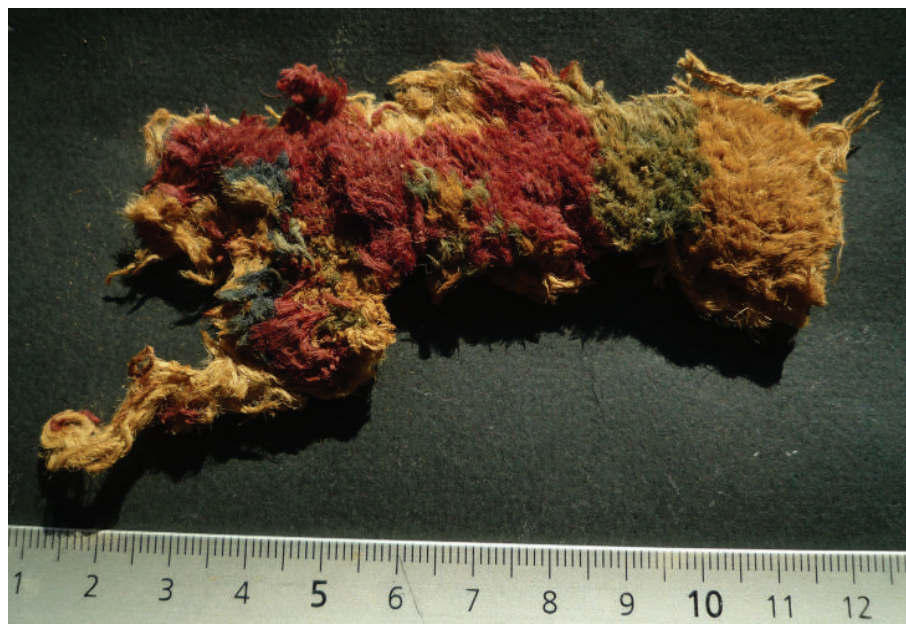

Fig. 3. X.506.22.1. Fragment of textile with pile (carpet?) from the rubbish heap in Xeron, with multicoloured pile wefts exceptionally well preserved
(© D. Cardon).



It is true that the humidity of the desert at Xeron has not generally allowed as good a preservation of wool textiles as in Didymoi, for instance. In Xeron, they usually are very squashed, crumpled, and coated with hardened mud due to being pressed between thick, heavy layers of rotten straw, ashes, and gravel from the important building work that took place in the fort (Fig. 2). But it looks as if in some parts of the rubbish heap, lenses or pockets of textiles had been kept isolated from the mass of debris and protected from decay, since some fragments come out of the ground looking as if they were new (Fig. 3). The great bulk of preserved textiles, nevertheless, consists of coarse, torn, soft furnishing and animal equipment, woven mostly from black-brown goat hair. Some rather small pieces of plain, undyed felt are also found, nearly completely encrusted with mud. Very few linen textiles have been preserved, mostly brown and hardened, like polymerized. But, in spite of the less favourable environmental conditions that prevailed in the rubbish heaps of Dios and Xeron, as compared to Didymoi, the quantity of material deposited was such that among masses of terribly worn and discoloured rags, some extraordinary discoveries have been made this year, once again (Fig. 3). The selection of textiles from Dios and Xeron that have been cleaned and fully studied during this mission demonstrates that both sites are greatly completing and enriching our knowledge of the textile production and clothing fashion in Roman Egypt during the three first centuries CE.

Most textiles from both sites appear to be remains of items of clothing, mostly woven in a range of twills and damasks which are more hardwearing than fine tabbies. They belonged to wool cloaks and mantles and several fragments are decorated with purple tapestry ornaments (Fig. 4 and p. in the present *ATN* issue). Some textiles, possibly coming from *kentrones* (swatches of assorted rags collected for recycling) are of such outstanding quality that I should not be surprised if true purple was identified among the selection that has been entrusted to Witold Nowik, from the Research Laboratory of Historical Monuments in Champs-sur-Marne, near Paris, for dye-analyses. The publication and discussion of fragments of diamond twills and damasks decorated with contrasting bands or tapestry ornaments that have been found in several *praesidia* is in preparation. Small fragments of black-blue cloaks in ribbed or block damasks, similar to those described in a section of our chapter on textiles from Didymoi (Cardon, Granger-Taylor and Nowik, forthcoming), were also found in Xeron, none, however, including a portion of curved selvedge as in several examples from



Fig. 4. Dios.5426.1. Fragment of extremely fine wool textile in diamond twill weave with thin purple notched band in tapestry (© D. Cardon).



Fig. 5. X.607.35.2. Fragment of tunic with greyish-purple clavus from Xeron (© D. Cardon).



Fig. 6. X.11808.1. Fragment of shaded band from Xeron (© D. Cardon).

Didymoi. Tunic fragments and fine wool tabbies in general, are much rarer, smaller and less well preserved in Dios and even less so in Xeron, than in other *praesidia* but they do occur in a range of colour combinations and qualities, including some fine shaded bands (Figs 5 and 6).

Some interesting soft-furnishing textiles have been found in the two sites: two fragments of *taquetés* from Dios, two more from Xeron (Fig. 7); several fragments of textiles with multicoloured pile, including a very well preserved example from Xeron (Fig. 3). Other interesting findings are small but well preserved fragments of multicoloured tapestries, one with geometrical motifs from Dios, three more with leaf motifs from Xeron - the first examples of curvilinear tapestries since our first discovery of such type of tapestry in Didymoi (Fig. 8). Also for the first time since our former studies of the textiles from Maximianon and Didymoi (Cardon 1998), a fragment of wool tabby in a red and yellow decorative pattern obtained by resist-dyeing was discovered in Xeron this year (fig. 9). It was found included in a *kentron*. A fragment of tubular twill weave with multicoloured stripes, of a type that had only been known so far through examples from Maximianon (Cardon 2003), Krokodilô and Didymoi, has been found in Xeron this year.

To conclude, the range of textiles found at these two sites confirms and completes our understanding of the textile products from similar sites previously excavated. Each new corpus studied brings new information, providing more examples of high

quality textiles that testify to the astounding virtuosity of the spinners, weavers and dyers who produced them. More importantly perhaps, finds from each new site allow to gradually build up a catalogue of textile types that were found in Egypt during the three first centuries CE and to define the range of technical variations that could exist within each type. The ultimate aim of our research is, by the patient study of the textiles from the rubbish heaps of the *praesidia*, to provide sound clues on such difficult



Fig. 7. Dios.14703.1. Big fragment of taqueté with geometrical design in blue and white included in a kentron (© D. Cardon).



Fig. 8. X. 808.13.1. Fragment of tapestry with curvilinear motifs from Xeron (© D. Cardon).



Fig. 9. X.807.21.1. Fragment of resist-dyed wool tabby from a kentron, with floral decoration in yellow on red ground (© D. Cardon).

questions as locating centres of production, defining characteristic technical specificities and recognising influences between different textile traditions, within the Roman Empire and beyond.

Acknowledgments

These excavations are conducted under the direction of Dr. H el ene Cuvigny, CNRS/Institut de Recherche et d'Histoire des Textes, Paris; funding : French Minist ere des Affaires  trang eres and Institut Fran ais d'Arch eologie Orientale (IFAO), Cairo; archaeologists conducting the excavations: Dr. Jean-Pierre Brun, CNRS/Centre Jean B erard, Naples, Pr. Michel Redd e, Ecole Pratique des Hautes Etudes, Paris, Dr. Emmanuel Botte (University of Lyon II); papyrologists : H el ene Cuvigny, Dr. Adam B ulow-Jacobsen, formerly Professor at the Carlsberg Foundation, Copenhagen, Denmark; textile specialists: Dr. Dominique Cardon, CNRS, and Dany Nadal (conservator), Association Materia Viva, Toulouse; dye chemist: Witold Nowik, P ole Analytique, Laboratoire de Recherche des Monuments Historiques (LRMH), Champs-sur-Marne, France.

Bibliography

- Cardon, D. (1998) Textiles arch ologiques de Maximianon-Al Zarqa : Exemples pr oces de teinture par r serve sur laine. *Bulletin du CIETA* 75, 14-20.
- Cardon, D. (2003) Chiffons dans le d sert : Textiles des d potoirs de Maximianon et Krokodil . In H. Cuvigny (2003), vol. 2, 619-659, 667-669.
- Cardon, D., A. B ulow-Jacobsen and H. Cuvigny (2010) Recent textile finds from Dios and Xeron. *ATN* 50, 2-13.
- Cardon, D., H. Granger-Taylor and W. Nowik (forthcoming) How were they dressed? Fragments of clothing found at Didymoi: case studies. In Cuvigny, H. (forthcoming).
- Cuvigny, H., ed. (2003) *La Route de Myos Hormos - L'Arm e romaine dans le d sert Oriental d'Egypte*. Cairo.
- Cuvigny, H., ed. (forthcoming) *Didymoi - Une garnison romaine dans le d sert Oriental d'Egypte*. Cairo.

Corresponding author: Dr. Dominique Cardon, Directrice de Recherche CNRS, CIHAM/UMR 5648, 18 quai Claude-Bernard, 69365 Lyon C dex 07, France ; cardon.dominique@wanadoo.fr.



Dominique Cardon and H el ene Cuvigny

New evidence and comparative study on fragments of hooded semicircular cloaks found in the Eastern Desert of Egypt

This paper offers a new complement to Hero Granger-Taylor's seminal publications on woven-to-shape semicircular cloaks in two recent issues of ATN (Granger-Taylor 2007, 2008). Archaeological excavations of a series of praesidia in the Eastern Desert of Egypt – the aims and results of which are summarized in ATN 50 and in the present issue – have provided several additional examples of fragments of textiles that could be identified as characteristic parts of hooded semicircular cloaks and, more precisely, in some cases, as parts of hoods. Such identifications are based on Granger-Taylor's precise descriptions of the technical details of a hooded semicircular cloak discovered in a grave in the Nubian site of Ballana, and of fragments of cloaks from Qasr Ibrim that she recognised as parts of a hood. The corresponding plans she proposed for a semicircular cloak and for its hood have helped us locate the position of some textile fragments from Didymoi and Dios belonging to cloak hoods, and to understand from which other parts of hooded semicircular cloaks some textile fragments from Dios and Xeron came (Granger-Taylor 2008, figs. 6, 8; Cardon et al. 2010, fig. 7; Cardon et al., forthcoming, fig. 322).

Fragments from the hoods of two more cloaks have just been identified this year, among the textile remains from Dios that had not been examined previously. They correspond respectively to a side and to the bottom right corner of a cloak hood (Fig. 1). They are published here with two fragments from another semicircular hooded cloak from Didymoi, which is not included in the forthcoming chapter on clothing

textiles from that site (Cardon et al., forthcoming). The fragments correspond respectively to one of the sides of the hood and to the upper part of a side section of the cloak (Fig. 2). The technical characteristics of this cloak are nearly identical to those of the cloaks in 1/2 twill from Dios.

In table 1 are summarized the common technical features and differences that can be observed among hooded cloaks identified so far in the rubbish heaps of praesidia excavated by our team. Three main types of hooded cloaks with decorative contrasting bands in tapestry are found so far: light cloaks woven in tabby, with thin purple bands on an undyed off-white ground; thicker cloaks woven in 1/2 twill, with broader, salmon pink to purple bands on grounds that range in colour from golden-beige to pinkish-orange. The third type, very similar to the Ballana cloak, consists of very high-quality, comparatively thin albeit very densely woven cloaks in tightly weft-faced 2/2 twill, with fairly wide red-purple bands on a cream-coloured undyed ground.

These three types of semicircular hooded cloaks are distinctive enough and it is tempting to think that they may have been given distinct names by the people who were making them or buying them. It is therefore frustrating to have to admit that, for want of associated descriptions, it is still impossible to connect any of them with one of the three names mentioned in ostraca of the Eastern Desert for outer garments, the first of which clearly designates a hooded garment, the two other – rather rare words – being much less descriptive. Koukoullon (from latin cucul-



Ref.	Date CE ¹	Ground weave	Weave in band	Tapestry technique at vertical joins	Spinning system ² ground	Spinning system band weft
<i>Didymoi</i> D98.4404.1 (Cardon <i>et al.</i> forthcoming)	176-210	tabby	Warp + weft paired in vertical part of band	Over shared paired warp end	s / s	s
D99.1516.1 (Cardon <i>et al.</i> forthcoming)	125-140	2/2 twill	2:2 twill	–	Z2s / z	z
D99.3321.2 + 3324.11.2	110-120	1/2 twill Z weft face	Warp grouped in vertical and horizontal parts of band 2:1:2 Weft paired in vertical part, simple in horizontal part of band	Over shared paired warp end	s / z	z
<i>Dios</i> Dios.4405.2 (Cardon <i>et al.</i> 2010)	mid 2 nd c.	tabby	Warp paired in vertical and horizontal parts of band Weft paired in vertical part, simple in horizontal part of band	Interlocking wefts	s / s	z
Dios.2403.1	c. 138-161 CE	tabby	Warp + weft paired in vertical part of band	Over shared paired warp end	s / s	s
Dios.5637.1 (Cardon <i>et al.</i> 2010)	2 nd c.	1/2 twill Z weft face	Warp + weft paired in vertical part of band	Over shared paired warp end	s / z	z
Dios.2506.1 (Cardon <i>et al.</i> 2010)	mid 2 nd c.	1/2 twill Z weft face	Warp + weft paired in contrasting band	Interlocking wefts	S2z / z	s
Dios.2720.1	c. 117-138 CE	1/2 twill Z weft face	Warp grouped in vertical and horizontal parts of band 2:1:2 Weft paired in vertical part, simple in horizontal part	Over shared paired warp end	s / z	z

¹ Date when fragment was discarded into the rubbish heap.

² Spinning system, explanation of notation : S / S = warp S-spin / ground weft S-spin.

Table 1. Technical characteristics of fragments of hooded semicircular cloaks decorated with contrasting bands or tapestry ornaments discovered in praesidia of the Eastern Desert of Egypt.

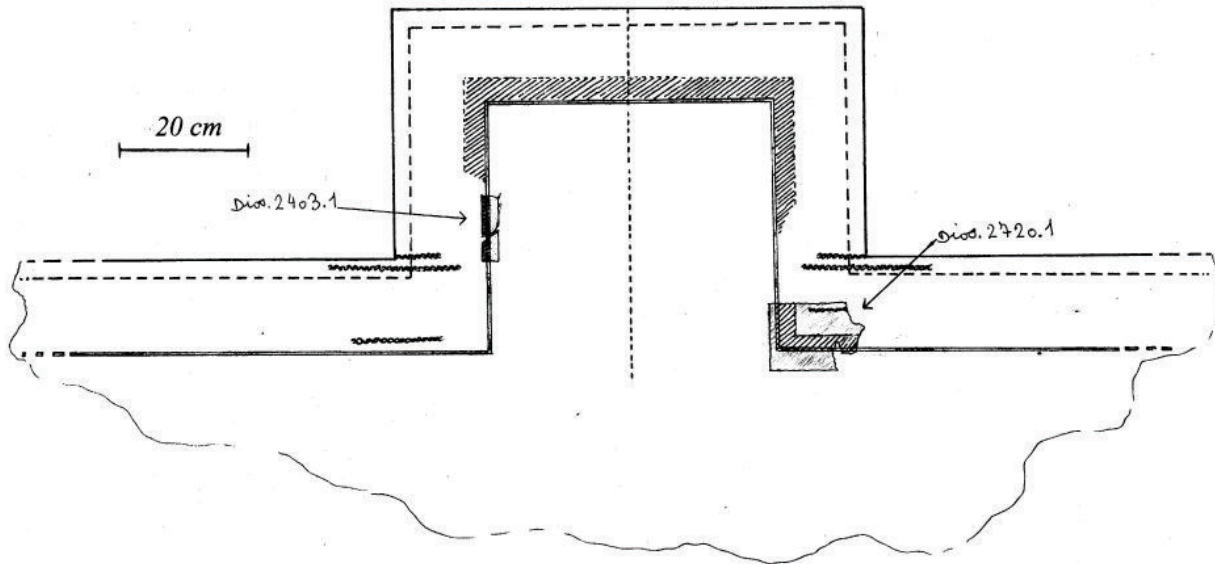

Fig. 1. Position of fragment Dios.2720.1 and proposed position for fragments Dios.2403.1. A + B on the outline of a hood reconstructed from fragments found at Qasr Ibrim. Drawing by J.M. Tarrant and H. Granger-Taylor (plan of hood) and D. Cardon (superposed fragments).

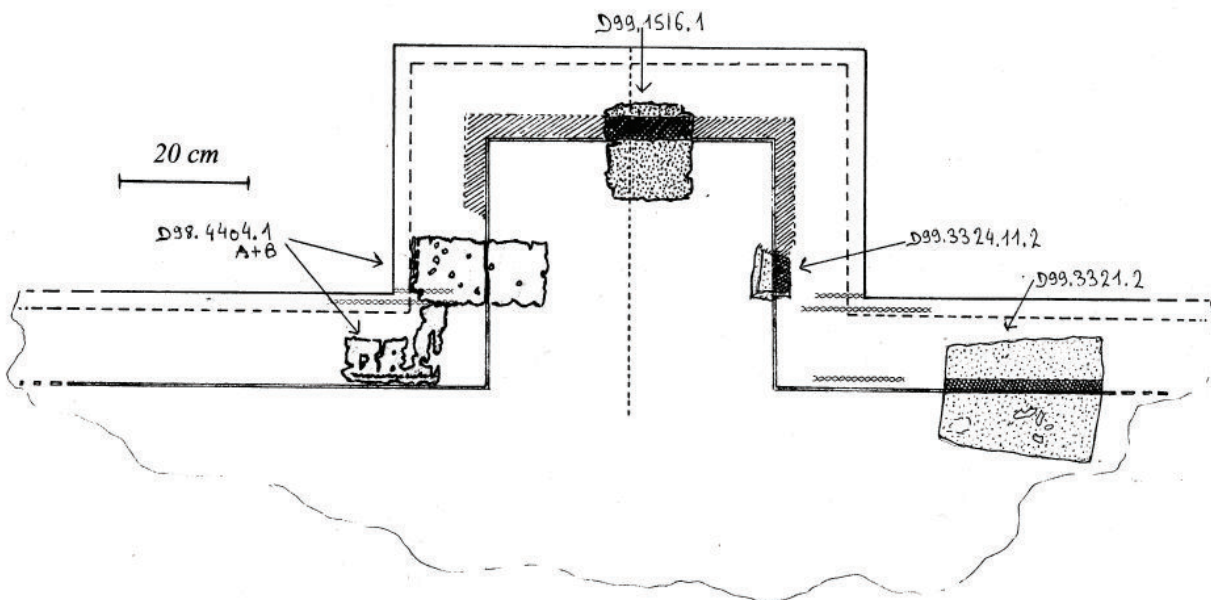

Fig. 2. Positions of fragments of hooded cloaks from Didymoi on the outline of a hood reconstructed from fragments found at Qasr Ibrim. Drawing by J.M. Tarrant and H. Granger-Taylor (plan of hood) and D. Cardon, H. Granger-Taylor and P. Cabrolhier (superposed fragments).



lus) is mentioned in an ostrakon from Dios, O.Dios inv. 750: "you will do well to send Apolinaris' cuculum. He has written to ask for it because the weather is bad". Aliklion (diminutive form of latin alicula, itself possibly derived from greek allix) is found on ostrakon O.Dios inv. 1298; and a paradromax ('mantle, wrap?') is mentioned in O.Dios inv. 548. In spite of the recurring difficulty of relating the names given to items of clothing in written sources to actual archaeological textiles and remains of garments, each new example of fragment from a semicircular hooded cloak identified, and published, contributes to enrich our understanding of the technical variations, the different colour combinations and the range of qualities which could be found in a type of garment that definitely appears to have been particularly valuable for soldiers.

Dios.2403.1. Two fragments of side of cloak hood in weft-faced tabby, undyed with part of mauve-pink vertical band in tapestry (Fig. 3)

Date : 2403 = discarded under Antoninus Pius' reign = c. 138-161 CE

Description

Dimensions, preservation

Fragment A, c. 5.3 x 2.25 cm; fragment B, c. 4.9 x 2.3 cm; width of pink vertical stripe preserved in both fragments: 1-1.1 cm; the fragments seem to have both been parts of a long narrow strip neatly cut from the original garment for re-use; preservation good but colour of contrasting weft possibly somewhat faded.

Technical characteristics

Wool, ground weave tabby, weft-faced, fine and close texture, very good quality; extended tabby with both warp and weft paired in mauve-pink vertical tapestry stripe; 7 groups of paired warp ends are preserved in both fragments; at the vertical joins between mauve-pink and ground wefts, paired threads of purple weft and single threads of ground weft alternately turn back around the same paired warp thread, creating a toothed effect.

Warp: undyed, light beige, tight S-spin, c.15 ends per cm (abbreviated epcm below); 4 paired ends (8 ends) in 0.5 cm in vertical band.

Ground weft: same colour as warp, tight s-spin, c. 28 picks per cm (abbreviated ppcm below).

Contrasting weft: mauve-pink, s-spin, paired, c. 28 ppcm (= 56 threads).

Dye identification of mauve-pink weft: the results of dye-analysis are not available yet.

Discussion

These fragments best compare with those of two cloak hoods, one already found in Dios (Dios.4405.2, published in Cardon et al. 2010) and the second from



Fig. 3. Dios.2403.1. A + B. Two fragments of side of cloak hood.



Didymoi (D98.4404.1 A+B), discarded between 176 and 210 CE as part of a kentron (Cardon et al. forthcoming). In Figure 1, the position of the fragment is shown on the outline of the plan of a cloak hood reconstituted by Granger-Taylor from hood fragments of the Roman period discovered at Qasr Ibrim, in Nubia (Granger-Taylor 2008, fig. 8). It could belong to either of the two sides of the hood. Similarities with these two cloaks from Dios and Didymoi are: the ground weave in tabby; in the three textiles, the warp and contrasting weft are paired in the vertical part of the pink to pinkish-purple bands and the tapestry technique used in the vertical joins between ground and band is the same. But there also are differences between the three textiles: here the warp count in the ground weave is slightly lower than in the two others. In the present fragments as in the fragment of hood from Didymoi, s-spin threads are used for the warp and for both ground and contrasting wefts, while the contrasting weft in the fragment from Dios

previously published is z-spun. Most importantly, in the fragments from Dios, the lesser thinness of the contrasting wefts betrays their lower quality, as compared with the amazing thinness of the weft, dyed with true purple, in the decorative band of the hooded cloak from Didymoi, approximately 150 threads of which can be counted per cm.

Dios.2720.1. Fragment of lower corner of cloak hood, decorated with a pink right-angle in tapestry, with reinforcement of weft twining (Fig. 4)

Date: 2720 = discarded under Hadrian's reign = c. 117-138 CE

Description

10.1 x 14.5 cm; pink stripe c. 3 cm wide in vertical part of tapestry angle, running parallel next to a vertical hem, c. 1 cm wide; horizontal part of pink right-angle c. 2.5 cm deep, running parallel to upper horizontal torn edge, at c. 3.8 cm from it, and to lower torn and folded-in edge, c. 2.8 cm from fold;



Fig. 4. Dios.2720.1. Fragment of lower corner of hood.



Fig. 5. Dios.2720.1. Detail of reverse face, showing remains of reinforcement in weft twining.

remains of double row of weft twining (only 5.3 cm preserved) running parallel the band where it is horizontal, c. 2.6 cm above it, and to upper torn edge, c. 0.5 cm under it, ending at c. 2 cm from the band where it is vertical (fig. 5); one big stabbing stitch in white linen (0.5 cm long) in bias direction, across the ground weave between the horizontal part of the band and the reinforcement in weft twining; much worn, with several holes both in the ground and in the pink parts; encrusted dirt; preservation medium, but pink contrasting weft still quite bright.

Technical characteristics

Wool, 1/2 twill weave (diagonal of the twill in Z direction on weft face) and tapestry in pink vertical band. Ground weave densely weft-faced, quality fine and dense. Warp threads grouped in both vertical and horizontal parts of pink band 2:1:2:1 etc.; pink weft threads are paired in vertical part of band, single in horizontal part; at the vertical joins between pink and ground wefts, paired threads of pink weft and single threads of ground weft alternately turn back around the same paired warp, creating a toothed effect. The twining reinforcement is worked over 3 warp ends and is made with pairs of plied threads.

Warp: golden beige, s-spin, shiny, c.14 epcm.

Ground weft: same colour as warp, slight z-spin, c.22 ppcm.

Contrasting weft: bright pink, slight z-spin, paired in vertical part of band, 21 ppcm (= 42 weft threads), simple in horizontal part, 37 ppcm.

Weft in rows of weft twining, same colour as ground weft, z-spin 2 S-ply, grouped by pairs.

Dye identification: results of dye-analyses of contrast-

ing pink weft not available yet.

Construction

For re-using the worn hood a torn vertical edge has been folded and hemmed in. Sewing thread in needlework edging, wool, now greyish-purple, paired z-spin 2 S-ply yarn.

Stabbing stitch, white linen, s-spin 2 Z-ply.

Discussion

In Figure 1, the position of the fragment is shown on the outline of the plan of a cloak hood from Qasr Ibrim as reconstituted by Hero Granger-Taylor. It most probably belongs to the right corner at the bottom of the hood and top of the right wing. This is shown by the remains of reinforcement of weft twining above the horizontal part of the band: such reinforcements are present at the bottom corners of the hood on the Ballana cloak and on two fragments of a hooded cloak from Didymoi (D98.4404.1 A+B). The position of the fragment on the right side of the cloak implies that the twill face with weft floats is the right – outer - face of the garment, which is the case for all cloaks woven in 1:2 twill with pile loops on the inner face (Granger-Taylor, pers. comm.).

The present fragment is quite similar to fragments of cloaks in fine brown weft-faced 1:2 twills found in Qasr Ibrim (Granger-Taylor 2008, 13-14) and to fragments of two different hooded cloaks in 1/2 twill from Dios published previously. The two other 1/2 twills from Dios, however, have different spinning systems for the ground weave, and the tapestry technique used at the vertical joins between purple and ground wefts also differs between the present fragment and Dios 2506.1. The presence of a big stabbing stitch in



white linen thread on this fragment makes it likely that it ended up in the rubbish heap at Dios as part of a kentron. In this hypothesis, the hooded cloak it originally belonged to, would have been woven much earlier and would probably not have been worn by one of the fort dwellers.

Two fragments of probably the same pinkish-beige hooded cloak with red-purple band from Didymoi

D99.3321.2. Fragment of pinkish-beige cloak, decorated with a red purple band, used as patch on piece of plain 1:2 twill (Figs 6-7)

Date: 3321 = discarded c. 115-120 CE

Description

22 x 36.3 cm; red purple band c. 2.2 cm deep, running at a maximum distance of c. 6.4 cm from upper torn edge; much worn, with several holes both in the ground and in the purple parts; encrusted dust; preservation medium.

Technical characteristics

Wool, 1/2 twill weave (diagonal of the twill in Z direction on weft face) and extended tabby in pinkish purple band. Ground weave densely weft-faced, quality fine and dense. Warp threads grouped in pink-purple band 2:1:2:1 etc.

Warp: pinkish-beige, tight s-spin, c.14 epcm.

Ground weft: same colour as warp, slight z-spin, c.24 ppcm.

Contrasting weft: red purple, slight z-spin, 40 ppcm.

Dye identification: results of dye-analyses of ground and of contrasting purple weft not available yet.

Construction

The less worn-out part of a cloak, with portion of the horizontal decorative band along the upper part of the wings, has been used as patch, by being folded and hemmed in along three sides and sewn by whipping stitches onto a piece of similar material. The weft face sides of the patch and of the piece onto which it has been sewn are facing each other. Sewing thread, wool, off-white, z-spin 2 S-plied.

Discussion

The patch with the purple band and the plain textile onto which it has been sewn most probably belong to distinct parts of the same original garment, since the technical characteristics of the ground weaves are the same. This is also true of the technical characteristics of the following small fragment, which is most probably a part of the hood of the same cloak. Results of dye analyses of ground and bands in both fragments may bring more elements to confirm or invalidate this hypothesis. Both textiles have been found exactly in the same part of the rubbish heap, but above each other, that is, in two adjacent superposed layers.

If they are not parts of the same original cloak, this would mean that there existed two - or three - nearly identical hooded cloaks, whose fragments were finally discarded around 115 CE in Didymoi. In any case, the technical similarities with the fragments of hooded cloaks in 1/2 twill from Dios - particularly Dios.2720.1 - show (Table 1) that they all belong to a standard type of cloak, possibly produced in the same textile centre.

This fragment also contributes interesting information to the on-going study of hooded cloaks of the Roman period found in Egypt: the distance preserved between the band and the torn upper edge is superior by c. 1.5 cm to the distance between the decorative band and upper horizontal edge with sewn edging in the Ballana cloak. This confirms H. Granger-Taylor's assumption that the cloaks were often refurbished, eliminating worn edges, and her reconstruction of the original dimensions of the cloak as being superior by at least 3 cm all around to those that could be measured on the remains found in the tomb.

D99.3324.11.2. Fragment of pinkish-beige cloak hood with red purple vertical band in tapestry (Figs 8-9)

Date: 3324 = discarded c. 110-115 CE

Description

C. 7.5 x 6 cm; vertical part of red purple band c. 2.7 cm wide (this is the original width, as shown by several preserved loops of contrasting weft turning back into the tapestry band on the side opposite to vertical hemming, fig. 7); running parallel to vertical hem (0.8 cm wide), at c. 2.2 cm from folded-in edge; worn, particularly purple weft in upper part of band, with holes both in the ground and in the purple band; preservation medium.

Technical characteristics

Wool, 1/2 twill weave (diagonal of the twill in Z direction on weft face) and tapestry in red purple vertical band. Ground weave densely weft-faced, quality fine and dense. Warp threads grouped in vertical purple band 2:1:2:1 etc.; purple weft threads paired in band; at the vertical joints between red purple and ground wefts, paired threads of contrasting weft and single threads of ground weft alternately turn back around the same paired warp, creating a toothed effect.

Warp: pink-beige, tight s-spin, c.14-16 epcm.

Ground weft: same colour as warp, slight z-spin, c.24 ppcm.

Contrasting weft: red-purple, slight z-spin, paired, 20 ppcm (= 40 weft threads).

Dye identification: results of dye-analyses of ground yarns and contrasting red-purple weft not available yet.



Fig. 6. D99.3321.2. and 3324.11.2. Fragments from cloak wing and from side of hood, weft face of patch with purple band and hood fragment.



Fig. 7. D99.3321.2. and 3324.11.2. Fragments from cloak wing and from side of hood, warp face of patch with purple band and side of hood.



Fig. 8. D99.3324.11.2. Fragment from side of hood, weft face of twill ground.

Construction

For re-using this part of worn hood, torn vertical and horizontal edges have been folded and hemmed in and the bottom hem in the weft direction has been sewn onto another piece of the same fabric; sewing thread, wool, off-white, s-spin, paired.

Discussion

All the patching, hemming and sewing work that was done to repair or recycle the original cloak - obviously considered a valuable piece of textile - may have taken place on the site, before the worn out fragments were eventually discarded. This would imply that the garment arrived with one of the fort dwellers. This extensive repairing and recycling work also means that the cloak was woven much earlier, possibly during the second quarter of the 1st century CE.



Fig. 9. D99.3324.11.2. Fragment from side of hood, warp face of twill ground.

Bibliography

Cardon, D., A. Bülow-Jacobsen and H. Cuvigny (2010) Recent textile finds from Dios and Xeron. *ATN* 50, 2-13.

Cardon, D., H. Granger-Taylor and W. Nowik (forthcoming) How were they dressed? Fragments of clothing found at Didymoi: case studies. In H. Cuvigny (ed.), *Didymoi - Une garnison romaine dans le désert Oriental d'Égypte*. Cairo.

Granger-Taylor, H. (2007) Weaving clothes to shape in the ancient world, 25 years on: corrections and further details with particular reference to the cloaks from Lahun. *ATN* 45, 26-35.

Granger-Taylor, H. (2008) A fragmentary Roman cloak probably of the 1st c. CE and off-cuts from other semicircular cloaks. *ATN* 46, 6-16.

Corresponding author: Dr. Dominique Cardon, Directrice de Recherche CNRS, CIHAM/UMR 5648, 18 quai Claude-Bernard, 69365 Lyon Cédex 07, France; cardon.dominique@wanadoo.fr.



Julian Subbert

Römisches Outfit in Cuxhaven

Einleitung

Im Jahre 1933 wurden beim Sandabbau am Galgenberg in Sahlenburg (heute: Stadt Cuxhaven, Niedersachsen) Gräber der Völkerwanderungszeit angeschnitten. In vielen Fällen benachrichtigten die Finder den Lehrer Karl Waller, welcher gleichzeitig Kreiskulturpfleger war. Dieser sicherte die Funde, erstellte Pläne und publizierte anschließend die Funde aus dem Bereich des Galgenbergs (Waller 1938). Die Dokumentation ist aufgrund der Bergungsumstände sehr spärlich. Sie umfasst einige Grab- und Übersichtspläne sowie kurze Beschreibungen. Waller konnte neben einigen naturwissenschaftlichen Bestimmungen auch die Textilien aus Grab 32 durch Schlabow untersuchen

lassen. Die Gewebereste aus Grab 34 blieben unbeachtet und sind nun Gegenstand dieses Artikels.

Der in der Nähe der Elbmündung gelegene Friedhof umfasst Körper- und Brandbestattungen. In der ersten Hälfte des 5. Jh. bricht die Belegung ab. Dieses Phänomen ist im weiteren Umkreis festzustellen und wird als Resultat der Abwanderung der Bevölkerung in die römischen Provinzen gesehen. Vielfältige Beziehungen zum römischen Kulturraum spiegeln sich in den anderen Funden der Region. Die Gräber 29 und 32 enthielten römische Gürtelgarnituren. Die Gürtelgarnituren werden als Hinterlassenschaft aus römischen Diensten zurückgekehrter Söldner gedeutet.



Abb. 1. Originalzeichnung aus den Akten der Stadt Cuxhaven: Lage der Funde in der Südwestecke. a = 2 Ringe, b = 1 Ring, c = Schnalle. Foto: J. Subbert.



Abb. 2. Cuxhaven-Sahlenburg, Fpl. Galgenberg, Grab 34, Ring a1. Foto: J. Subbert.

Die Bestattung

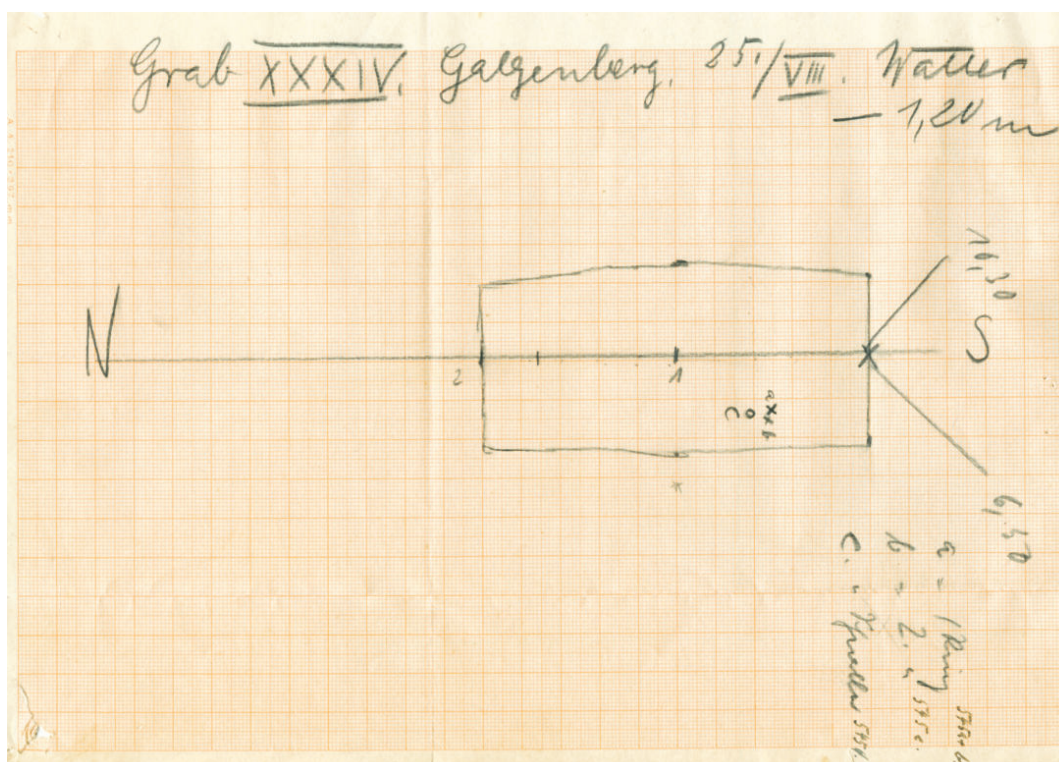
In dem Körpergrab, dessen Nordostseite schon in die Sandgrube abgestürzt war, wurden vier Beigaben angetroffen: drei bronzene Armringe und eine eiserne Schnalle (verschollen). Die Ringe lagen im Grab zusammen mit der Schnalle im Südwestbereich des Grabes, die Ringe 50 cm, die Schnalle 60 cm von der südlichen Schmalseite entfernt. Waller spricht in seinem Bericht (Archiv Cuxhaven) davon, dass die Ringe am linken Arm der Toten gewesen wären. Er erwähnt aber ausdrücklich die schlechte Knochenhaltung und dass nur in zwei (anderen) Gräbern Leichenschatten beobachtet worden seien (Waller 1938, 86). Die Angabe zur Lage der Armringe am linken Arm hat er nicht in die Publikation übernommen. Es bleibt also die Möglichkeit, dass die Armringe neben der Toten lagen. Falls sie angelegt waren, kommt eine Seitenlage der Toten in Frage, wie sie auch in anderen, zeitgleichen Gräbern beobachtet wurde.

Waller war der Ansicht, es handele sich um ein Mädchengrab. Er stützt seine Meinung jedoch nur auf die eiserne Schnalle, die dem Typ nach eine Kinderschnalle sei.

Die Funde

Zunächst sollen die Ringe beschrieben werden, um eine spätere Zuordnung zu den Abdrücken auf den Geweben zu ermöglichen.



Abb. 3. Cuxhaven-Sahlenburg, Fpl. Galgenberg, Grab 34, Ring a2. Foto: J. Subbert.

Ring a1: Aus zwei Drähten s-tordiert. 20 vollständige Drehungen auf einer Länge von ca. 18,5 cm (1,1 Drehungen pro cm, Abb. 2).

Ring a2: Aus zwei Drähten z-tordiert. 18 vollständige Drehungen auf einer Länge von ca. 19,5 cm (0,9 Drehungen pro cm, Abb. 3).

Ring b: Aus drei Drähten s-tordiert. Fünf vollständige Drehungen auf einer Länge von ca. 12 cm (0,4 Drehungen pro cm, Abb. 4). Nur an einem Ende sind die Drähte etwas herausgezogen und die Drehung damit weniger eng.

Bei zweien ist die Steigung (= Drehungen/ cm) identisch. Die beiden Ringe gleicher Steigung unterscheiden sich in ihrem Drehsinn (z und s, vgl. Abb. 5). Daher sind die meisten Abdrücke auf den Geweberesten einem der drei Ringe zuzuordnen.

Datierung und Einordnung des Grabes

Die Datierung gestaltet sich schwierig, da nur die drei Armringe erhalten sind. Alle tordierten Bronzearmringe des Gräberfeldes von Krefeld-Gellep sind in das 4. Jh. n. Chr. datiert worden (Pirling 2006, 345-346). Dies deckt sich mit der Datierung der übrigen Körpergräber des Cuxhavener Friedhofes. Es wurde vermutlich während der Belegungszeit des Bestattungsortes angelegt, welche sich von D1 bis D2 erstreckt (370/80 bis 440/50) (Böhme 1999, bes. 70-72).



Im freien Germanien wurden nur selten Armringe mit ins Grab gegeben. Noch seltener sind mehrere Armringe in einem Grab. Die Ringe wurden meist in Frauengräbern gefunden, doch gibt es einige Männerbestattungen mit einem Armring. Die Sitte, mehrere Armringe mit ins Grab zu geben, ist hingegen sehr gut in den römischen Provinzen belegt. Als Beispiele seien Krefeld-Gellep (Nordrheinwestfalen) und Lankhills (Winchester) genannt (Clarke 1979). Nur in einem Grab des 3. Jhs. (Krefeld-Gellep, Grab 1316) war ein Mann mit einem Armring bestattet worden (Pirling 2006, 342).

Die Gewebe

Es liegen fünf größere Organik-Fragmente vor und einige weitere kleine, die aber keine weiterführenden Informationen erbrachten. Fast alle Reste ließen sich zwei Geweben zuordnen.

Textil A ist aus z-gesponnenen Wollgarnen in einfacher Tuchbindung gewebt. Die Garne haben eine Stärke von 0,4-0,5 mm. Das Garnsystem I ist weniger scharf gesponnen und weist einen roten Farbton auf. Die Garne des Systems II sind etwas feiner, schärfer gesponnen und dunkel (blau?). Die Vermutung, dass es sich um gefärbte Garne handelt, wurde später bestätigt (s.u.). Die Fadendichte in System I beträgt 14 pro cm, die von System II zehn pro cm (Abb. 6).



Abb. 4. Cuxhaven-Sahlenburg, Fpl. Galgenberg, Grab 34, Ring b. Foto: J. Subbert.

Textil B ist ebenfalls aus z-gesponnenen Wollgarnen hergestellt, doch unterscheidet sich die Bindungsart. Es handelt sich um eine so genannte Halbpanama-Bindung (*half-basket weave*, erweiterte Leinwandbindung mit doppeltem Schusseintrag). Die Garne der beiden Fadensysteme sind mittelfest gesponnen und haben beide eine rötliche Tönung. Die Fadenzahl in System I beträgt 9 pro cm; die Garnstärke ist 0,5 mm. Die Garnstärke in System II (Doppelfäden) ist 0,4 mm; die Fadenzahl 22 pro cm. Dieses Gewebe war gewalkt oder beidseitig geraut (Abb. 7).

Da einige Fragmente mehrere Zentimeter lang sind und an keiner Stelle ein Fragment mit beiden Gewebefassungen auftritt, ist es unwahrscheinlich, dass es sich um einen Musterwechsel oder eine Kantenbildung handelt. Auch die technischen Merkmale sprechen für zwei verschiedene Gewebe.

Die Befunde

Die Fragmente sind mit aa, ab, ad, ae und b bezeichnet. Diese Bezeichnungen rühren von der Bestimmbarkeit der Textilien her und haben keine weiteren Implikationen.

Fragment aa:

Das Fragment besitzt den Abdruck von zwei Armringen. Es ist 30 mm mal 17 mm groß. Der eine Abdruck stammt von einem s-tordierten Ring; die Steigung beträgt 2,5 (fünf Drähte auf 2 cm). Der Abdruck stammt demzufolge von Ring a1. Der andere Abdruck ist von einem z-tordierten Ring, also Ring a2.

Fragment ab:

Das Fragment ist lang gestreckt und besitzt den Abdruck eines Armringes. Es ist 42 mm lang. Der Abdruck stammt von einem s-tordierten Ring; die Steigung beträgt 1,75 (3,5 Drähte auf 2 cm). Der Abdruck stammt demzufolge von Ring a1.

Fragmente ad und ae:

Sie werden hier zusammen besprochen, da sie nach einem Restaurierungsfoto ehemals zusammenhingen. Die Fragmente weisen Abdrücke von zwei Ringen auf. Die Größe der zusammengesetzten Fragmente ist 32 mm mal 20 mm. Ein z-gewundener Abdruck stammt von Ring a2. Der andere Abdruck ist s-gewunden und hat eine Steigung von 2,5 (sechs Drähte auf 2,3 cm) und ist daher als Ring a1 zu bestimmen.



Abb. 5. Cuxhaven-Sahlenburg, Fpl. Galgenberg, Grab 34, Textilfragment b (Textil B).
Foto: J. Subbert.



Abb. 6. Cuxhaven-Sahlenburg, Fpl. Galgenberg, Grab 34, Textilfragment b (Textil A mit
Armringabdrücken und der Rückseite von Textil B oben rechts. Foto: J. Subbert.



Abb. 7. Schematische Darstellung der Armringe und der Orientierung der Garne des Gewebes A System I (rot) im Verhältnis zu den Armringen. Grafik: J. Subbert.

Die stratigrafische Abfolge der Fragmente aa bis ae ist:

Ring a1 | Ring a2

1/1 Gewebe

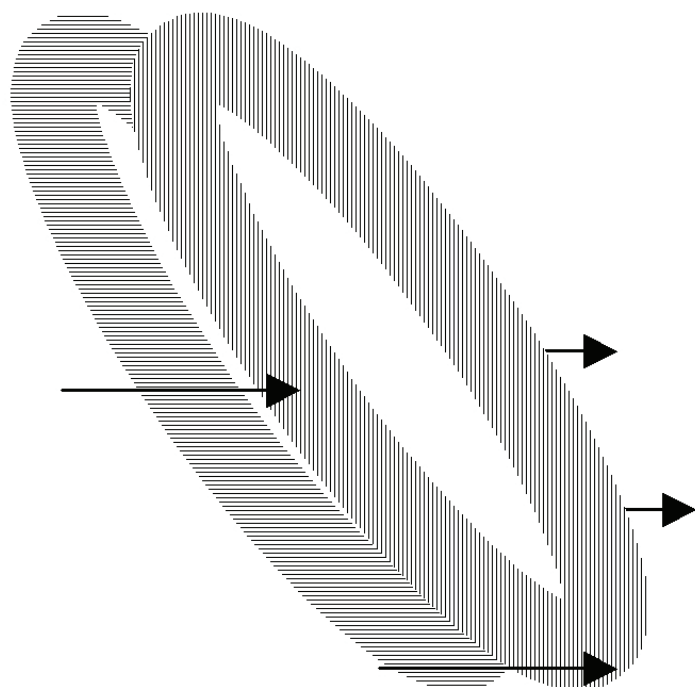
1/1-1 Gewebe

Gekreuzte Halme

Fragment b:

Das Fragment ist 21 mm mal 14 mm groß und trägt die parallelen Abdrücke von zwei Ringen. Ein Abdruck ist z-gewunden und stammt von Ring a2. Der andere ist s-gewunden und hat eine Steigung von 2,0 (zwei Drähte auf 1 cm) und stammt daher von Ring a1.

Die stratigrafische Abfolge ist:

Ring a1 | Ring a2

1/1 Gewebe

1/1-1 Gewebe

Die Gesamtlänge der Abdrücke von Ring a1 beträgt 104 mm, die von Ring a2 33 mm. Ring b hat keine Abdrücke hinterlassen bzw. die organischen Reste sind nicht erhalten.

Ärmel eines Unter- und eines Obergewandes?

Da die Ringe einen Außenumfang von ca. 20 cm

aufweisen, ist also gut die Hälfte mit Gewebe bedeckt gewesen. Die Fragmente folgten der Rundung der Ringe und lagen außen an den Armringen an. Das innere Gewebe (A) bedeckte sie eng und faltenfrei. Das äußere Gewebe lag ebenfalls eng an, hatte aber an einer Stelle möglicherweise eine zweite Schicht. Dabei könnte es sich um eine Falte gehandelt haben.

Die Ausrichtung der Garnsysteme des Gewebes A im Verhältnis zu den Armringen spricht für ein schlauchförmiges Gewebe. Wären sie in ein Tuch eingeschlagen gewesen, so könnten nicht alle Garne eines Systems gleich ausgerichtet gewesen sein, sondern müssten an einigen Fragmenten quer verlaufen und Falten bilden. Eine Naht konnte nicht festgestellt werden, obwohl diese vorhanden gewesen sein dürfte. Die Armringe wären demzufolge angelegt gewesen und direkt auf der Haut des Armes getragen worden. Außen um die Armringe lag das schlauchförmige Gewebe eng an. Das innere Gewebe (Textil A) soll also an dieser Stelle als Ärmel gedeutet werden. Gleiches gilt für Gewebe B. Es könnte der Ärmel eines Übergewandes gewesen sein, allerdings sind mit der Falte auch andere Möglichkeiten

vorstellbar. Die doppelten Schussgarne (Syst. II) von Gewebe B verlaufen wie System I von Gewebe A. Auch wenn die Beweisführung von den wenigen Fragmenten zu den Ärmeln nicht zwingend ist, so erscheint sie mir doch als beste Deutung.

Eine abweichende Deutung solcher Ringe schlägt Vera Brieske vor. Sie deutet sie als Beutelverschluss (Brieske 2001, 220-226 Textilien dazu Möller-Wiering 2005, 40-42). Aufgrund der Textilbefunde ist diese Deutung für das Grab 34 in Cuxhaven ausgeschlossen.

Farbanalyse

Beide Garnrichtungen der Gewebe A und B sind verprobt worden und durch Ina Vanden Berghe am Institut Royal du Patrimoine Artistique (KIK/IRPA, Brüssel) mittels HPLC-PDA) untersucht worden (Tabel 1). Ausdrücklich danken möchte ich der Stadt Cuxhaven, die Textiluntersuchungen und besonders auch die Analyse der Färbemittel finanziell unterstützt hat.

Die indigoiden Färbesubstanzen können vom Färberwaid stammen. Eine andere indigotine Färbesubstanz ist Purpur, welcher hier aber nicht



nachgewiesen ist. Die übrigen Analyseresultate lassen keine Rückschlüsse auf Färbesubstanzen zu. Ungeklärt bleibt der Nachweis von Indigotin aus den roten Garnen. Falls es sich um zweifach (rot und blau) gefärbte Garne gehandelt haben sollte, etwa zur Nachahmung von Purpur, dann wäre der rote Farbstoff sichtbar, aber nicht mehr nachweisbar; der blaue nicht mehr sichtbar, aber noch in der technischen Analyse feststellbar. Eine weitere häufiger vorkommende Erklärung ist die Kontamination des rötlichen Garnes durch die blaue Farbe des anderen Garnes. Dieser Analysebefund bleibt also etwas rätselhaft.

Folgerungen

Die Bindungsart Halbpanama ist typisch für römische Kleidung, wie Susan Möller-Wiering (2007, 255-256) erst kürzlich für die Moorleiche von Oberaltendorf herausgestellt hat. Schon John Peter Wild (2002, 20) war anhand von britischem Material zu diesem Schluss gekommen. Auch die Nachbehandlung (Walkung oder Rauung) des Gewebes ist typisch für den römischen Kulturbereich und kommt im germanischen Raum nicht vor (Subbert & Möller-Wiering forthcoming, mit weiterführender Literatur). Auch die Färbung der Garne korrespondiert mit der übrigen Machart der Gewebe, auch wenn das Färben ebenfalls im germanischen Bereich möglich war. Da nun nicht nur die Gewebe, sondern auch die

Bestattungssitten (Beigabe mehrerer Armringe) dem römischen Kulturkreis entstammen, ist dieses Grab nicht als sächsisch anzusprechen. Ich halte es für möglich, dass hier eine Frau mit römischer Kleidung in römischer Weise bestattet wurde.

Für den römischen Bereich hat Mary Harlow (2004) die Entwicklung der Frauenkleidung anhand der Bilddenkmale nachgezeichnet. Während im 2. und 3. Jh. die Dalmatica mit weiten Ärmeln beliebt war, wurden im vierten und den folgenden Jahrhunderten unter einer ärmellosen Übertunika Gewänder mit sehr eng anliegenden Ärmeln getragen, welche in bunten Manschetten enden konnten (z.B. Serena, zusammen mit Stilicho auf einem Elfenbeindiptychon um 400 n. Chr.). In Grab 34 konnte nun ein langer, enger Ärmel nachgewiesen werden.

Danksagung

Danke an Andreas Schünemann-Wendowski, Ina Vanden Berghe, Susan Möller-Wiering und Birthe Haak für die Hilfe und die Diskussion der Befunde.

Gewebe	Code KIK/IRPA	Analysenr.	Beschreibung	Komponenten	λ (nm)	Biologische Färbesubstanz
A Syst. I	09517/08 AcEt	04/250907/01	Rotes z-Garn	100 in (PHB, D', B', MPHD)	255 288	Färberwaid (Isatis tinctoria/ L.)
A Syst. II	09517/09 AcEt	05/250907/01	Blaues z-Garn	8,5ea, 91.5in (PHB, B', MPHB)	255 288	Färberwaid (Isatis tinctoria/ L.) und Tannin
B Syst. I	09517/06 AcEt	06/250907/01	Rotes z-Garn	(Spuren von) 100 in (PMB, D', B')	255/ 288	Färberwaid (Isatis tinctoria/ L.)
B Syst. II	09517/07 AcEt	03/250907/01	Rotes z-Garn (Doppelfaden)	100 in (PHB, B', MPHB)	255 288	Färberwaid (Isatis tinctoria/ L.)

Tabel 1. Analyse der Farbstoffe aus den Geweben A und B. Analysis Report by Ina Vanden Berghe, KIKIRPA (Brüssel), 18/02/2008.

**Literatur**

Böhme, H.W. (1999) Sächsische Söldner im römischen Heer. Das Land zwischen Ems und Niederelbe während des 4. und 5. Jahrhunderts. In: Über allen Fronten. Nordwestdeutschland zwischen Augustus und Karl dem Großen. Katalog zur Ausstellung. Archäologische Mitteilungen aus Nordwestdeutschland, Beiheft 26, Oldenburg, 49-73.

Brieske, V. (2001) Schmuck und Trachtbestandteile des Gräberfeldes von Liebenau, Kr. Nienburg/Weser. Vergleichende Studien zur Gesellschaft der frühmittelalterlichen Sachsen im Spannungsfeld zwischen Nord und Süd. Studien zur Sachsenforschung 5, 6.

Clarke, G. (1979) Pre-Roman and Roman Winchester. Part II: the Roman Cemetery at Lankshill. Winchester Studies 3, Oxford.

Harlow, M. (2004) Female Dress, Third – Sixth Century: The Message in the Media? In: *Antiquité tardive* 12, 203-215.

Möller-Wiering, S. (2005) Symbolträger Tracht. Textilarchäologische Untersuchungen zum sächsischen Gräberfeld von Liebenau, Kr. Nienburg (Weser). Studien zur Sachsenforschung 5, 8.

Pirling, P. (2006) Schmuck. In R. Pirling und M. Siepen, Die Funde aus den römischen Gräbern von Krefeld-Gellep. Germanische Denkmäler der

Völkerwanderungszeit, Serie B, Die fränkischen Altertümer des Rheinlandes, Bd. 20, 340-365.

Subbert, J. & Möller-Wiering, S. (forthcoming) Roman Iron Age in Germany. In *Textiles and Textile Production in Europe from Prehistory to AD 400*. Edited by M. Gleba and U. Mannering. Oxbow.
Waller, K. (1938) Der Galgenberg bei Cuxhaven. *Hamburger Schriften zur Vorgeschichte und Germanischen Frühgeschichte*, Bd. 1, Leipzig.

Berichte im Archiv der Stadt Cuxhaven.

Analysis Report: Archaeological textile fragments from 2 graves from Cuxhaven-Sahlenburg, Lower Saxony (Northern Germany) Galgenberg: grave 29 and 34. By Ina Vanden Berghe, KIKIRPA (Brüssel), 18/02/2008.

Ausgrabungsbericht von K. Waller.

Foto 545-2 zum Restaurierungsbericht von V. Fendel.

Corresponding author:
Julian Subbert M.A.
Universität Hamburg
Edmund-Siemers-Allee 1, ESA West
20148 Hamburg
JulianSubbert@web.de

Ida Demant

From stone to textile: constructing the costume of the Dama de Baza

In 2007 Professor Carmen Alfaro Giner, University of Valencia contacted Anne Batzer, hand weaver at the Textile workshop at Sagnlandet Lejre, Historical Archaeological Research and Communication Centre, with a request of producing a textile replica of the costume of the Dama de Baza. This life-size stone statue representing a woman dressed in a characteristic Iberian costume is dated to the 3rd century BC and still preserves traces of colour (Fig. 1). The sculpture is cremation urn and was recovered from one of the two necropoleis of the Ibero-Roman town of Baza in the northeast area of the province of Granada, Spain. The figure is seated in an armchair, and an open space in its side is believed to have contained ashes from a cremated person. The costume of the figure presumably represents the costume of a woman belonging to the elite of Iberian society, and similar costumes have been noted on other contemporaneous figurines and statues (Alfaro Giner forthcoming). Characteristic for these outfits are a tunic and a large mantle which covers most of the body, sometimes combined with an elaborate headdress.

The work constructing the costume was initiated in 2009 by Anne Batzer and the author, and is briefly presented here.

The Dama de Baza is depicted in a costume consisting of four garments and a headdress. Besides a mantle which covers her head and body, she is also wearing a tunic. Both these costume items have traces of a blue colour on the surface and are decorated with the same blue and red checked borders. Details depicted above the feet suggest the presence of two undergarments which are longer than the tunic and have no colour traces. The shape of these garments is not evident. Translating this information into a life-size 3D functional costume was not an easy task

and demanded a good deal of experimenting and a profound knowledge of ancient textile production and costume traditions.

In ancient times, it was common to dye wool textiles, whereas linen was praised for its whiteness. Thus it was decided to produce the blue mantle and tunic in wool and the undergarments in linen. Linen is a soft



Figure 1. The lady of Baza on display at the National museum of Madrid (Photo Julia Martínez).



and smooth material which would have been nice to wear next to the skin, whereas wool worn as the outer layers would have offered insulation against both heat and cold.

The greatest challenge in making this costume, however, was to find the right shape of the garments, so when placed on a seated mannequin they would look like the garments on the statue. Costumes produced at the time of the Dama de Baza were rarely cut and sewn to shape. More commonly rectangular off-the-loom pieces of cloth were draped around the body (Granger-Taylor 1982). Only few (if any) edges were cut and hemmed before the garments were ready to wear.

While it seemed likely that the tunic and the undergarments were based on rectangular shapes, it was soon realised that the mantle needed a more

elaborate shape to create the desired folds along the front edge. The angled corners by the feet of the statue indicate that the mantle should have at least one straight edge, but in order to create the characteristic folds of the border at the front of the mantle, a curving edge would be necessary. Therefore we experimented with various semi-circular shapes in order to get the right effect of a wavy frontline. The result was a garment that was 230 cm long and 140 cm high at the maximum, which would fit a woman 160 cm high. The reconstructed mantle was woven to shape on a modern treadle loom, but the semicircular shape could also be woven on an upright warp-weighted loom. It was an important factor in this project that theoretically the garments should be possible to produce using tools and techniques known to the Iberian craftspeople.

After the mantle fabric was finished the checked



Figure 2. The fabric for the mantle before adding the border (Photo: Ida Demant).

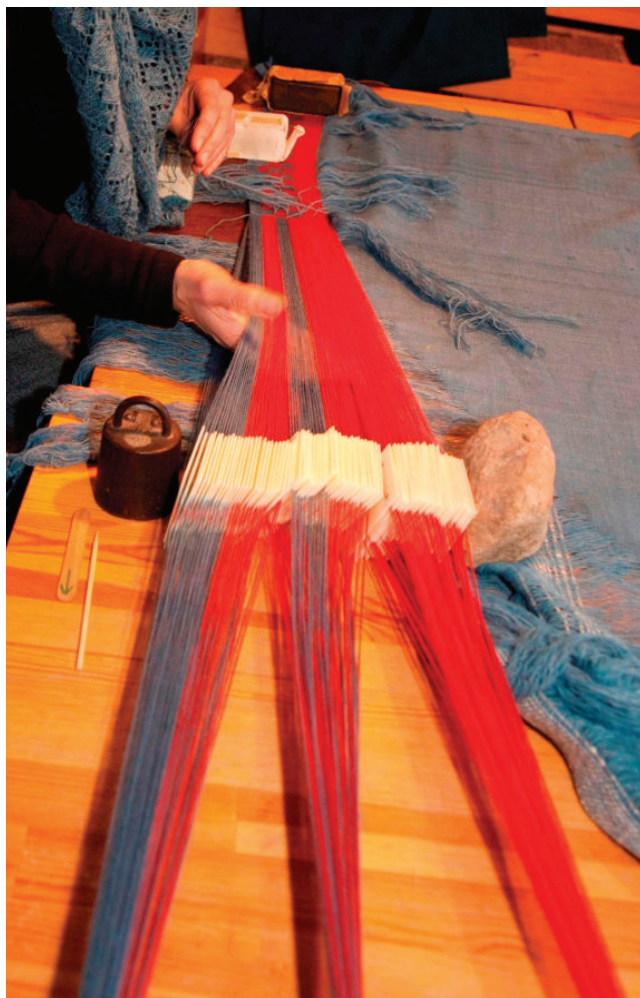

border was added using the tablet weaving technique. This is a very common method for weaving borders. In Spain tablet weaves dated to the 4th century BC have been found, which are contemporary with the Dama de Baza (Hundt 1968). The long loose warp ends were used as weft threads in the tablet weave and in this subtle way it was possible to make a border that followed the curving edge of the mantle (Fig. 2). On the statue the border is 8 cm wide. To make it this wide we had to use 84 tablets, each holding 4 warp threads (Figs. 3 and 4). It was possible to weave 7-8 cm/hour, and as the border had to be 3.5 m long, it took approximately 50 hours to make this border. This recording gives a hint of the time invested in textile production in antiquity.

The shape of the three other garments cannot be deduced directly from the statue, and was thus open for interpretation. Nevertheless, it was imperative that they should reach the ground, be wide enough for walking and be based on rectangular shape, as common at the time of the Dama de Baza. On this basis it was decided to make wide sleeved tunics for the blue tunic and for one of the undergarments. The other undergarment was made as a skirt. A skirt used as the middle garment, would further give the

Figure 3. The checked border is added to the mantel using the loose warp-ends as weft in a tablet weave (Photo: Ole Malling).



Figure 4. A close-up of the tablet-woven border during weaving. (Photo: Ole Malling).



advantage of holding the inner tunic tight at the waist and adding a better drape to the tunic. As the tunic and the mantle have several identical details, similar colours and the checked borders, which indicate that they were technically related, they were also produced in the same kind of fabric. The fabric for the two undergarments was also hand-woven in two different qualities – a fine linen fabric for the inner tunic and a coarser quality for the skirt.

Conclusion

Semicircular mantles and cloaks are though rare known in archaeological textile finds (Stauffer 2002, Granger-Taylor 1982). In the case of the Dama de Baza

the mantle was worn with the curve turned upside, whereas in most cases we would have been inclined to think that they were worn with the curve turned downwards. The textile replica of the outfit of the Dama de Baza is not a reconstruction of an original costume from the 4th century BC in Southern Spain, but it offers a suggestion to how the costume might have looked and how it could have been produced (Fig. 5). As such, experiments reconstructing ancient costumes are an excellent way of testing and communicating theories about various methods for textile production and how costumes were worn. The textile replica of the Dama de Baza will in due time be incorporated in the DressID exhibition “*DressCode im Alten Rom – Kleidung und Identität der Antike*” which will open in Mannheim in February 2012.



Bibliography

Alfaro Giner, C. (forthcoming) Aspekte der weiblichen Iberischen Kleidung. In *DressCode im Alten Rom – Kleidung und Identität der Antike (exhibition catalogue)* Mannheim.

Granger-Taylor, H. (1982) Weaving cloth to shape in the ancient world: the tunic and toga of Aringatore. *Textile History* 13, 3-25.

Hundt, H. J. (1968) Die Verkohlte Reste von Geweben, Geflechte, Seilen und Schnüren aus Grab 200 von El Cigarralejo. *Madridrer Mitteilungen* 9, 187-205.

Stauffer, A. (2002) I tessuti. In P. Von Eles (ed.) *Guerriero e sacerdote. Autorità è comunità nell'età del ferro a Verucchio. La Tomba del Trono*, Firenze, 192-219.

Figure 5. The textile replica of the Dama de Baza (Model: Helle C. Andersen; Photo: Ole Malling).



Susan J. Foulkes

Roman Rigid Heddles: a Survey

Introduction

Plain weave narrow bands can be produced using a shed stick and heddle rod. A more efficient way of making the plain weave sheds utilises an implement called a rigid heddle. This simple device is a frame consisting of a series of slots and holes through which the warp is threaded (Fig. 1). The plain weave sheds are made by raising and lowering the heddle. The earliest evidence for rigid heddles is from the Roman era. Currently, nine Roman heddles are known (Table 1).

Description of the heddles

London, UK: KWS94<1344> [4345] (Fig. 2)

The heddle has been made from a flat, single piece of bone. It is incomplete as both ends are missing.

The top of the frame has two incised lines which run parallel to the top edge. It was found in Regis House, a waterfront site. It comes from the 63-64 CE fill and is probably pre-Boudican in date (J. Hall pers. comm. 2008). It measures 47 mm x 21 mm with a maximum thickness of 2mm and has three slots and four holes. This heddle is conserved in the Museum of London.

Pompeii, Italy

Wild (1970, 74:4) describes this heddle in a footnote. It is said to be made of bone and has the largest number of holes and slots of this group of heddles. It is conserved in the Antiquarium of Pompeii.

Xanten, Germany: X7338 (Fig. 3)

The heddle is made from one piece of bone and

Provenance	Number of slots (s) and holes (h)	State of preservation	Material	Date
London, UK	3 s 4 h	Incomplete	Bone	63-64 CE
Pompeii, Italy	10 s 11 h	Not known	Bone	Before 79 CE
Xanten, Germany	3 s 3 h	Incomplete	Bone	50-100 CE
Briord, France	6 s 7 h	Complete	Bronze	1 st century CE
Budapest, Hungary	5 s 5 h	Incomplete	Antler	First half 2 nd century CE
Lingenfeld, Germany	3 s 3 h	Incomplete	Bronze	350 CE
Lauriacum-Enns, Austria	3 s 4 h	Fragmentary	Bronze	Late 4 th century CE
Pilismarót, Hungary	5 s 6 h	Broken but complete	Bronze	Late 4 th century CE
South Shields, UK	5 s 5 h	Incomplete	Bronze and bone	Not securely dated

Table 1.



Fig. 1. A modern rigid heddle set up to produce a narrow linen band: plain weave, warp dominant weave, warp faced weave and tubular weave. Photo: Susan J. Foulkes.



Fig. 2. Rigid heddle from the Museum of London, UK made from a flat, single piece of bone. It measures 47 x 21 mm. Photo: Susan J. Foulkes.

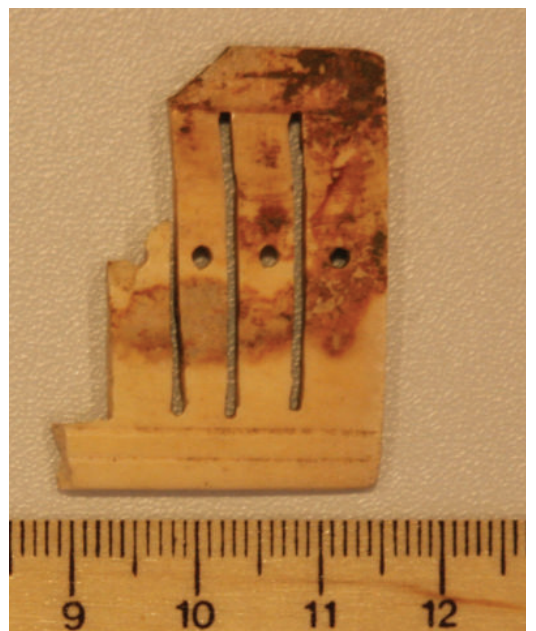

Fig. 3. Heddle from Römer Museum, Archaeological Park, Xanten, Germany made from one piece of bone. It measures about 25 x 25 mm. Photo: Susan J. Foulkes.

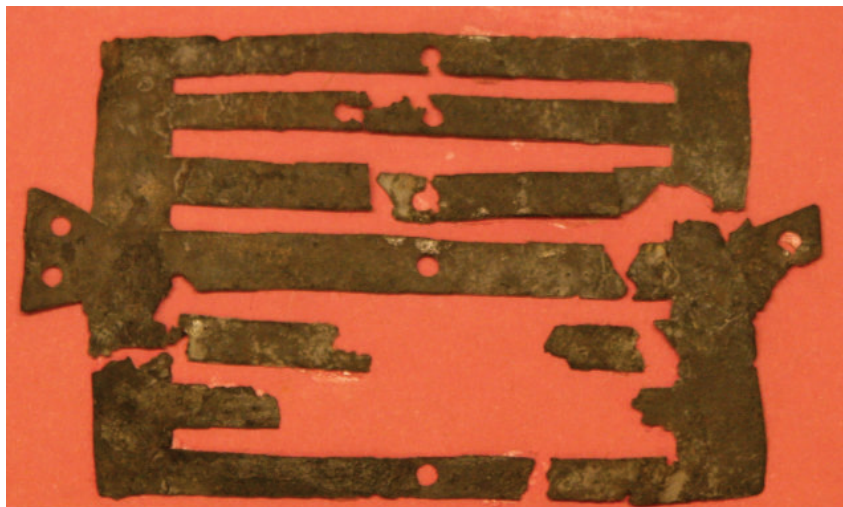

Fig. 4. Bronze rigid heddle from Briord, France measuring 65 x 46 mm. Photo: Susan J. Foulkes.

measures about 25 mm x 25 mm. Visual inspection indicates similarities with the London heddle. For example, there are incised lines along the top and bottom of the frame. There is also a faint line across the centre of the slats, which may have served as a guide line for centering the holes in the slats. It is broken across one corner. This heddle is conserved in the RömerMuseum in the Archaeological Park Xanten.

Briord, France (Fig. 4)

In the catalogue of the

archaeological collections of the museum in Briord (Perraud, 1971, 59) the heddle is described as measuring 65mm x 46 mm. There are seven slats, each with a hole and six slots. In the middle of the top edge there is a trapezoidal shape with two holes. Along the bottom edge this feature is broken and only one hole remains. Perraud suggests that a wood or ivory sheathing could have been riveted to the top and bottom edges. A line drawing showing how it was used is published in Grange et al. (1963, fig. 14, pl. 18) and in Roche-Bernard et al (1993, 79). The heddle is conserved in the museum of Briord.

Budapest, Hungary: 2006.16.1

This heddle is carved from an antler and has 6 slats, one of which is missing its central section. There are two incised lines along the top and bottom of the frame. On one side it is decorated with two dolphins facing each other. It measures 6 cm x 4 cm x 0.2 cm. It was found in 2006 in house number XXIX of the Civil Town of Aquincum, and is conserved in the Museum of Aquincum. It is illustrated in the catalogue of the Archaeological Finds of 2006 from an exhibition in 2007 (Aquincum Museum Catalogue, 2007).

Lingenfeld, Germany

This late 4th century CE heddle was found in 1907 (Weiser 1999). It has four holes and three slots. It is made of bronze but is fragmentary. It is listed in the report of the historical association of Plafz (Bernard, 1981, 5ff, Taf.2,7).

Lauriacum-Enns, Austria: RVI 295

This incomplete bronze heddle is described as having four slats (only three with holes) and three slots (Ulbr, 1997, 133 Kat. Nr. IV/A-34). It is conserved in the Museum Lauriacum in Enns.



Fig. 5. Heddle from South Shields, UK measuring 77 x 45 mm. Photo: Susan J. Foulkes.



Pilismarót, Hungary

This bronze heddle was found in a grave with a male skeleton and dates from the late 4th century CE. A line drawing is published in Barkoczi (1960, 113 fig. 30 no. 10). It is complete although broken across one corner. On one side slat there is an additional hole at the top and bottom, function unknown. Not illustrated but mentioned in the text is the decoration of circles parallel to the holes. It measures 88 mm x 60 mm. Unlike the Briord example, there are no trapezoidal flanges on the long edges to fix a sheath. The description speculates that it may have been a counting tablet or abacus but the line drawing clearly shows the form of a heddle.

South Shields, UK (Fig. 5)

This heddle was first described by Bosanquet (1919, 227) whose papers were published by Cowen (1948). The heddle was purchased by a Robert Blair from workmen on the site of the Roman fort at the Lawe in South Shields. These building works destroyed the Roman settlement from 1874 onwards. Blair's collection of artefacts from the site was deposited in the Black Gate Museum and it is considered that the heddle is probably Roman in origin. It is now displayed in the Great North Museum, Hancock, Newcastle-upon-Tyne.

As in the case of the heddles from London and Xanten, the frame is carved from a single piece of bone. There are five slats, one side slat is missing. Each slat has a hole in the centre and is decorated with six pairs of concentric circles. This decoration appears on both sides of the slats. The existing side slat has two additional holes at the top and bottom. Although these additional holes pierce the centre of the circle decoration on one side of the slat, on the obverse side the hole cuts through the incised circle. Therefore they seem to have been made after the circle decoration. One suggestion is that these additional holes are to fix the heddle in a side frame. Wild (1971) gives the measurements as 77mm x 45mm. The sheathing on the top and bottom of the bone frame is silvered bronze. This sheathing is held in place by three double-headed silver rivets. It is decorated with a pattern of crosses and incised vertical lines in pairs. There are indications of wear on the central holes.

Suggested uses of the heddles with examples

Heddles are used to produce plain weave or warp faced bands. Wild (2002, 11) suggests that heddles and tablets may have produce bands for girdles, bandages, webbing or headbands. However, the known Roman heddles have few holes and slots, so

the width of bands that can be produced is limited; this restricts the range of uses.

There are examples of narrow warp faced bands from Ancient Egypt which could have been made using a shed stick and heddle rod. On the wide end of the Rameses girdle displayed in the World Museum in Liverpool, there is a warp-faced band woven in fine linen. It binds the end of the girdle and forms two loops for the fastening. It has 83 warp ends in red, white and blue. (Bienkowski, P. and Tooley, A. M. J. 1995, 46 pl 59) A similar band is found on the neck opening of the so-called Syrian tunic of Tutankhamun (Crowfoot and Davies 1941, 120-122). Another example is sewn around the edges of the tunic of Kha, in the Museo delle Antichità Egizie in Turin (Donadoni Roveri, 2001, 39 pl. 38) although Hall (1986, 36) and Allgrove-McDowell (2003, 39) describe them as tapestry woven bands. Nonetheless, these bands are warp-dominant plain weave as the weft is visible. They are wider than the previous two examples and made of coarser linen. They have a practical as well as a decorative function. Such bands strengthen the edges of the garment around the arm and neck openings and the bottom border. However, all these bands use a large number of warp threads. The Roman heddles can only produce bands considerably narrower.

Using a Roman rigid heddle it is possible to produce four types of woven structure making bands of decreasing widths:

1. Plain weave: where the number of warp and weft picks is the same.
2. Warp-dominant weave: where the weft is pulled so that the warp ends move closer together and some weft is still visible.
3. Warp-faced weave: where the weft is pulled tightly so that the warp ends pack together so closely that the weft is not visible.
4. Tubular weave: where the weft is always entered from the same side. This produces a tube. Also, this method can be used to weave a narrow edging on a piece of cloth if a needle is used for the weft rather than a shuttle. The needle goes through the cloth after each pick.

Illustration of uses for a small rigid heddle

To illustrate the range of uses for a small rigid heddle, I wove the four types of weave using a limited number of warp ends. The two rigid heddles illustrated are modern Swedish examples. The known Roman heddles had a limited number of holes and slots. This allows only narrow bands to be produced. To explore the possibilities, I used a thick yarn (tapestry wool) and a fine yarn (16/2 linen) to make



	Balanced plain weave	Warp- dominant weave	Warp- faced weave	Tubular weave
16/2 linen	12 mm	7 mm	4 mm	Approx. 2.5 mm (ten warp ends used)
Anchor tapestry wool	24 mm	13 mm	7 mm	Approx. 4 mm

Tabel 2.

two warps, each of nine threads and one warp of 10 threads of fine linen. Bands of the different widths were produced (see tabel 2).

The thick tapestry wool produces serviceable narrow bands at all widths (Fig. 6). I found that plain weave linen bands at this width are difficult to achieve. The band tends to be unstable, but the warp-dominant and warp-faced bands are sturdy and narrow (Fig. 1). The linen bands are so narrow that their possible uses are limited. One use could be a narrow tie which fastened puttees just under the knee (Croom 2000, 57). A tubular band made with a rigid heddle is strong but a plaited or finger-woven band is easier to produce and needs no special equipment.

On a warp-weighted loom, tablets can be used to weave a starting border and make the warp. A rigid heddle could also be used (Hoffman 1964, 65). The Roman examples are not ideally suited for this purpose. The height of the heddles does not provide a deep shed for a larger skein or ball of warp thread to pass through. In addition, the heddles made from a single piece of bone may be too fragile.

Ræder Knudsen (2002, 228-229) has shown how tablets were used to provide decorative and strengthened side borders for material woven on a warp-weighted loom. There would be no practical benefit in using a rigid heddle in this way as a plain weave shed is already produced by the action of the loom itself.

A possible use for a small rigid heddle is adding a woven tubular border onto an existing cloth.

The small size of the heddle is an advantage when weaving an edging as a larger piece of equipment would be intrusive. I produced two tubular edgings with nine warp ends of wool and ten warp ends of 16/2 linen. The needle takes the weft through the shed in the same direction throughout and is also used to beat the weft in the shed (Figs 7 and 8).

Conclusion

The known examples of the Roman rigid heddle are well-produced, sometimes decorative objects. They afford a neater, more efficient method of weaving than is offered by the existing shed sticks and heddle rods. However, as I hope my practical researches have shown, such rigid heddles are suitable for only a limited range of woven products. This survey may stimulate further discussion as to the possible uses of this innovative piece of weaving equipment. It is evident that heddles have not always been recognised as such in museum collections; perhaps more Roman rigid heddles might yet be identified.



Fig. 7. Wool tubular weave with nine warp ends joining two pieces of felt. Photo: Susan J. Foulkes.



Fig. 8. 16/2 linen tubular weave with ten warp ends edging felted wool. Photo: Susan J. Foulkes.



Fig. 6. Three bands made using the same heddle and tapestry wool yarn. Plain weave, warp dominant weave and warp faced. Photo: Susan J. Foulkes.

**Bibliography**

Allgrove-McDowell, J. (2003) Ancient Egypt 5000-322 BC. In Jenkins, D. (ed) The Cambridge History of Western Textiles, 30-39. Cambridge.

Aquincum Museum Catalogue (2007)
<http://www.aquincum.hu/programok/katalogusangol.pdf>

Barkóczi, L. (1960) Késörómaitemető Pilismaróton. *Folia Archaeologica* XII, 113-132.

Bernard, H. (1981) Der spätrömische Depotfund von Lingenfeld, Kreis Germersheim, und archäologische Zeugnisse der Alamanneneinfälle zur Magnentiuszeit in der Pfalz. *Mitteilungen des historischen Vereins der Pfalz* 79.

Bienkowski, P., and Tooley, A.M.J. (1995) *Gifts of the Nile*. London.

Bosanquet, R.C. (1919) *Archaeologia Aeliana* XIV, 227.

Cowen, J. D., ed. (1948) A Bone Weaving-Frame from South Shields in the Black Gate Museum. *Archaeologia Aeliana* 4, XXIV, 88-97.

Croom, A. T. (2000) *Roman Clothing and Fashion*. Stroud.

Crowfoot, G. M., and Davies, N. de G. (1941) The Tunic of Tutankhamen. *Journal of Egyptian Archaeology* 27, 113-130.

Donadoni Roveri, A. M. (2001) *The Art of Weaving*. Turin.

Grange, A., Parriat, H., and Perraud, R. (1963) La nécropole gallo-romaine et barbare de Briord (Ain). *La Physiophile (Monceau-les-Mines)* 39e année, 58, 68-70.

Hall, R (1986) *Egyptian Textiles*. Shire Books: Princes Risborough.

Hoffman, M. (1964) *The Warp-Weighted Loom*. Oslo.

Perraud, R. (1971) *Catalogue des Collections Archéologiques du Musée de Briord (Ain) : Société D'archéologique de Briord, La Physiophile* 75.

RæderKnudsen, L. (2002) La tessitura con le tavolettenella tomba 89. In P. vonEles (ed.) *Guerriero e sacerdote. Autorità e comunità nell'età del ferro a Verucchio. La Tomba del Trono*, 220-234 Firenze, *All'Insegnadel Giglio*.

Roche-Bernard, G., and Ferdieri, A. (1993) *Costumes et Textiles en Gaule Romaine*. Paris.

Ubl, H. ed. (1997) *Katalog zur Schausammlung „Romerzeit“ des Museums Lauriacum-Enns*, Bd 2. Enns/Wien.

Wieser, M. (1999) Neues zu römischem Webwerkzeug. *Mitteilungen des Museumvereines Lauriacum-Ens* 37, 11-14.

Wild, J.P. (1970) *Textile Manufacture in the Northern Roman Provinces*. Cambridge.

Wild, J.P. (1971) The South Shields Heddle. *Archaeologia Aeliana* 4 XLIX, 230-231.

Wild, J. P. (2002) The Textile Industries of Roman Britain. *Britannia* 33, 1-42.

e-mail: s.j.foulkes@btinternet.com



Olga Orfinskaya and Olga Lantratova

Female costume of the Golden Horde period from burial 93 of the Maiachnyi Bugor I cemetery in the Astrakhan region of Russia

There are many dress remains recovered from various sites of the Golden Horde. Finds of complete costumes are, however, unique. In the summer 1991, the Astrakhan archaeological expedition headed by S.A. Koten'kov carried out excavations of the heavily damaged Maiachnyi Bugor I cemetery near the Krasnyi Yar village in the delta of the Volga River in the Astrakhan region of Russia. This Golden Horde cemetery dates to *ca.* AD 1250-1400. Among the excavated complexes a female burial 93 dated to the late 13th century AD is of particular interest since it enables one to reconstruct the complete set of female dress of the Golden Horde time, including underwear (Orfinskaya *et al.* 2006). All the grave goods from the burial, including clothes, are kept at the Archaeology Department of the State Historical Museum in Moscow.

Description

The following articles were identified while examining the excavated textiles (Fig. 1, Tables 1, 2):
– Red silk underwear referred to below as “red underwear” was found on the skeleton. It looks like a corset covering the chest and belly and fastened at the back with three laces. The remains of warmth-keeping lining made of plant fibre and fragments of underlining of cotton fabric as well as parts of sewn-

on leather appliqué details were found on the inside of the garment. The width, shape and multilayer structure of the article enable us to surmise that it is either a maternity belt or a corset for a very plump woman helping to distribute pressure at the waist evenly. Possibly the so-called “belly-cover-wrappers” encountered in male burials of the Yuan dynasty functioned as medical corsets (*Gold, Silk, Blue and White Porcelain* 2005, 63, 85).

– Trousers of a fine silk fabric lay over the “red underwear” below the waist. Trousers of a similar cut are well known from North Caucasian Alan cemeteries of the 8-9th century AD (Yerusalimskaya 1992, 45; Orfinskaya 2001, 206). This model, however, has a wide belt with laces regulating its width at the waist. The belt has a clear imprint of a figurative buckle, indicating that the trousers were decorated. A short blouse (Blouse 3) only reaching the waist was made of the same fabric as the trousers. These two garments may be regarded as an underset.

– Fragments of two more blouses were found between the short blouse and the underwear. Only cuffs with three buttons survived of one of them and a part of the flap with long straight sleeves of the other.

– The under gown (Gown 3) is made of red brocade fabric with brown trimming at the collar and sleeves.



Tabel 1. Underwear from burial 93 of Maiachnyi Bugor I.

Description of garment	Drawing of surviving fragments
<p>Underwear corset Height 70 cm Maximum width 290 cm Main fabric - silk damask Lining - cotton Lining filling - cotton wool Appliqué details - leather</p>	
<p>Underwear corset Height 70 cm Maximum width 290 cm Main fabric - silk damask Lining - cotton Lining filling - cotton wool Appliqué details - leather</p>	
<p>Underwear corset Height 70 cm Maximum width 290 cm Main fabric - silk damask Lining - cotton Lining filling - cotton wool Appliqué details - leather</p>	
<p>Underwear corset Height 70 cm Maximum width 290 cm Main fabric - silk damask Lining - cotton Lining filling - cotton wool Appliqué details - leather</p>	
<p>Underwear corset Height 70 cm Maximum width 290 cm Main fabric - silk damask Lining - cotton Lining filling - cotton wool Appliqué details - leather</p>	



Reconstruction of cut



Reconstruction of appearance

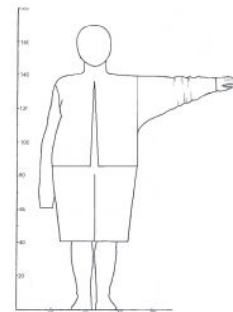
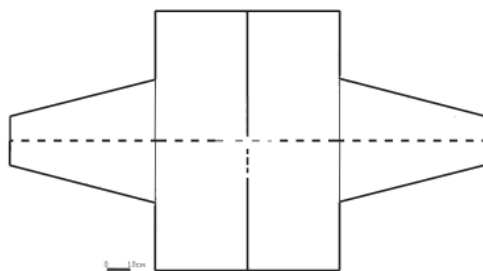
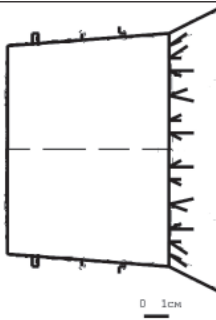
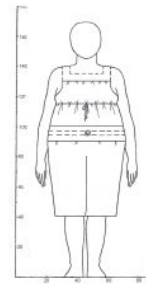
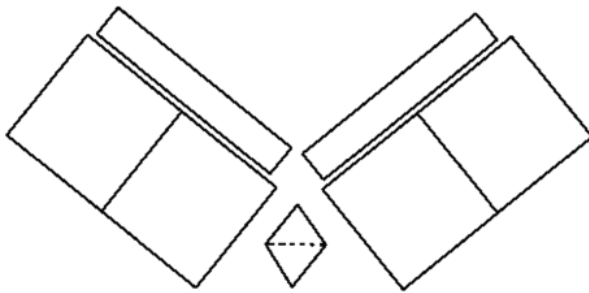
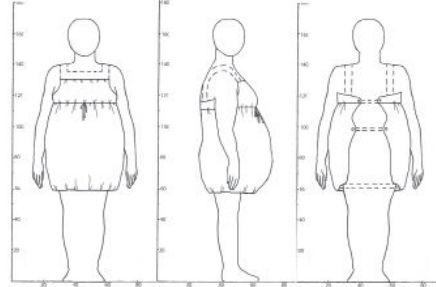



Tabel 2. Outer gowns from burial 93 of the Maiachnyi Bugor I.

Description of garment	Reconstruction of cut
<p>Inner gown 1 Height 125 cm Width at sleeves 192 cm Main fabric - brocade with "trees" on red background Trimmings - brocade with "clouds" on brown background Lining and laces - silk taffeta Lining filling - cotton taffeta</p>	
<p>Intermediate gown 2 Height 140 cm Width at sleeves 198 cm Main fabric - brocade with "texts" on brown background Trimmings - brocade with "playing animals" Trimmings - brocade with drop-shaped medallions Laces - gauze Lining - silk taffeta</p>	
<p>Outer gown 3 Height 85 cm Width at sleeves 72 cm Main fabric - brocade with "small clouds" on brown background Trimmings - brocade with "texts" on brown background Lining - cotton taffeta Lining filling - cotton wool</p>	



Reconstruction of shape

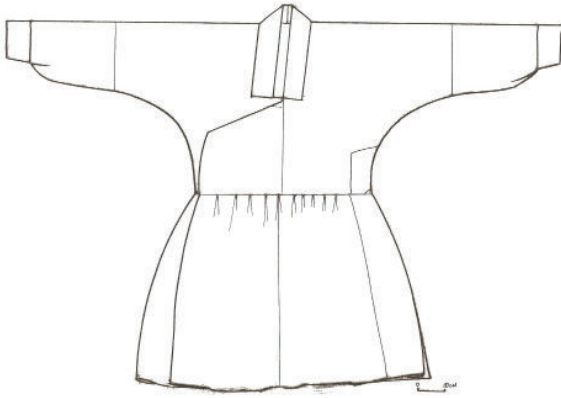

Reconstruction of appearance

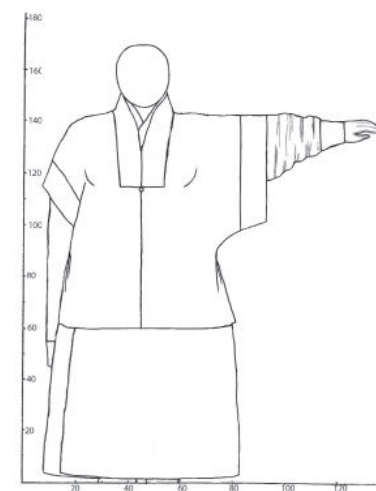
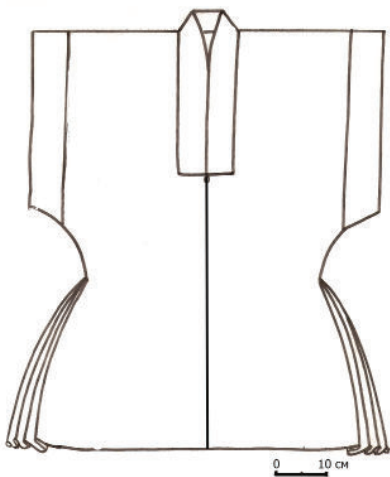
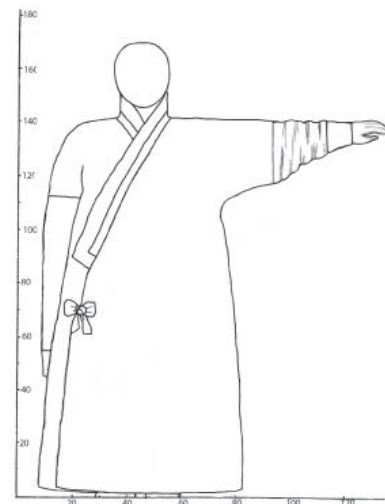



running between the blouses and the under gown was found at the head and neck area. The bands ran under the blouse and lay next to the woman's body. The headdress was made of gauzy fabric with dark tabby underlining. Silk threads surviving at the ends probably attached additional ornaments, such as beads or silk tassels. A balaclava-shaped cap covered the neck and was buttoned with a single soft button under the chin. Traces of a minor repair implying that the cap was worn in life can be seen at certain parts of seams. The shape resembles that of male headdresses but it is possible that the cap was worn under a smart female headdress, for instance, the *bokka* (Mys'kov 1995, 40-41).

– Remains of leather boots and details of their silk trimming were found at the feet of the skeleton. Well-preserved boots with similar trimming were found at the Maiachnyi Bugor II cemetery (Lantratova *et al.* 2002a, 46-48).

– Fabric fragments of a pillow case were encountered near the head of the deceased.

– The dead body was placed on a rectangular cushion of red brocade. Remains of several layers of a dark cotton-fibre fabric have survived on the inside of the cushion. Stripes of red silk damask some 10 cm wide were sewn on to the short sides of the cushion. The fabric is identical to that of the above-described corset.

The analysis revealed a total of 12 garments made of 26 fabrics.

Textile fibres

The nature of textile fibres was determined by microscopy with the use of a reference collection of standard samples. The fibres identified included silk and cotton. Silks are the principal fabrics for dress-making. Brocade is used on the right-side of the garments and their trimming, while simple undyed tabby fabrics serve as lining and underwear. Red damask is the base of underwear, the lining of the collar of a gown and the trimming of the cushion. The tabby fabrics used either for keeping warmth as in the under gown or for lining as in the outer gown and the cushion consist of cotton fibres. The warmth-keeping cotton wool is used in red underwear and the outer gown.

Gilt membrane strips

Brocades contain two kinds of gilt membrane strips, the flat and spun ones. Flat gilt strips are made of animal bowels, the so-called membranes, faced with gold leaf on one side. Spun gilt strips are made in the same way but then wrapped around a silk core. The gilt membrane strip is wrapped round the silk

core in the Z-direction. They measure from 0.3 to 0.5 mm in thickness while the dimension of the twist pitch show a spread from 0.4 to 0.9 cm due to a fairly pronounced destruction of threads.

The metal composition of the gilt membrane strips is similar in all the threads analysed with gold making up more than 93%.

Methods and results of the study of gilt membrane strips in the Golden Horde brocade fabrics were discussed at length elsewhere (Jaro 1998, 141-148; Lantratova *et al.* 2002a, 172-180; Lantratova *et al.* 2002b, 245-249).

Dyes and dyeing technology

Textile dyes were examined using HPLC technique in N.N. Vorozhtsov Institute of Organic Chemistry of the Russian Academy of Sciences in Novosibirsk. The results are presented in Table 3.

Brown threads are dyed with tannin dyestuffs and an iron mordant. Besides tannins and iron cations, indigotin, a blue vat dye, was found in the threads of the main dark brown fabric of the headdress. Such a mixture of dyes was used in the Middle Ages to obtain a deep black colour of a fabric (Golikov, Semikin and Zharikova 2010, 41). It allows us to surmise that the headdress fabric was originally black.

Red fibres were dyed with mordant dyes made of madder roots. It should be noted that the red colourant of the damask can be easily removed even by water treatment. It may be indicative of the presence of a direct dye, which does not form stable complexes with silk fibres. Such a situation may be accounted for either by the destruction of the colourant after a long exposure to soil or an inherent flaw in the dyeing process.

The red-brown fabric with drop-shaped medallions and the openwork fabric of laces of the same colour were probably dyed with shikonin extracted from the roots of *Lithospermum erythrorhizon* native to China, Korea and Japan (Cardon 2007, 60), suggesting that fabrics dyed with this colourant were manufactured in China.

Black cotton lining of Gown 3 is dyed dark blue with a vat indigo dye. The finished fabric was piece dyed in a strong solution of the dye.

Fabric patterns

It is impossible to carry out an in-depth analysis of fabrics without a detailed art historical study. In this paper, however, we will only dwell upon the techniques used in the pattern design of the brocades (Table 4).

The simplest way of introducing design into a weave



No.	Garment	Textile colour	Dye	Possible dye source
<i>Headdress</i>				
1	Main fabric	dark brown	indigotin, tannins	indigo; tannin-containing plants
2	Lining	brown	tannins	tannin-containing plants
<i>Underwear corset</i>				
3	Main fabric	red	galiosin, pseudopurpurin, purpurin, alizarin	madder (<i>Rubia</i> sp.) roots
<i>Gown 1 with "tree" pattern</i>				
4	Main fabric	red	alizarin, purpurin	madder (<i>Rubia</i> sp.) roots
5	Cuffs and collar	brown	tannins	tannin-containing plants
<i>Gown 2 with "text" pattern</i>				
6	Main fabric	brown	tannins	tannin-containing plants
7	Cuff and collar trimmings	brown	tannins	tannin-containing plants
8	Cuff and collar trimmings	red-brown	shikonin	purple gromwell (<i>Lithospermum erythrorhizon</i>)
9	Collar lining	red	galiosin, pseudopurpurin, purpurin, alizarin	madder (<i>Rubia</i> sp.) roots
<i>Gown 3 with "small cloud" pattern</i>				
10	Main fabric	brown	tannins	tannin-containing plants
11	Collar	brown	tannins	tannin-containing plants
12	Lining (cotton)	black	indigotin	indigo
<i>Mat</i>				
13	Main fabric	red	alizarin, purpurin	madder (<i>Rubia</i> sp.) roots

Table 3. Dye analyses.

can be seen in the "tree" pattern fabric (Fig. 2). It is a diagonal grid where the decorative elements symmetrical to the vertical axis, the trees, are positioned at crossings. The design of the "cloud" fabric (Fig. 3); is based on the same principle but its elements are not symmetrical and therefore the fabric composition is more complex. The next degree of sophistication is the change of direction of non-symmetrical design elements positioned at every second crossing of the diagonal grid. This group includes the fabrics with "small clouds" and "birds". The next stage is the apposition of two diagonal grids with different mesh dimensions. It is represented by the fabric with "texts" where discs (Fig. 4) are placed at the crossings of the larger grid in either direct or mirror position, while trefoils

are situated at crossings of the smaller one (Fig. 5). This fabric has not only two elements differing in scale and symmetry but also a decorative stripe. The design of the stripe, like the entire fabric, is vertical. It enables one to differentiate between the various fabrics of the gown and to determine with a certain degree of confidence that selvages run across the fabric approximately every four meters. The fabric featuring "playing animals," namely leverets, has the most complex pattern. Its design is distinguished by a thin brown line against a lamé ground. The animals are depicted on sides of triangles connected by a complex "lamellar" grid. The complex pattern of the grid made it possible to fill the field of the fabric with a seemingly dynamic and varied design though the animals are only featured in three positions.



Tabel 4. Patterned fabrics from burial 93 of the Maiachnyi Bugor I.

	Pattern drawing	Pattern composition	Short description
1			<p>Gown 1 Main fabric with "trees". Composition - diagonal grid. Structure - damask on tabby base.</p>
2			<p>Gown 1 Fabric of trimming with "clouds". Composition - diagonal grid. Structure - lampas.</p>
3	<p>Trefoil element</p> <p>Main element: disc with text</p>		<p>Gown 2 Main fabric with "small texts". Composition - complex or double diagonal grid. Structure - lampas.</p>



	Pattern drawing	Pattern composition	Short description
4			<p>Gown 2 Fabric of trimming with "playing animals". Composition - complex "lammellar" grid. Structure - lampas.</p>
5			<p>Gown 3 Main fabric with "small clouds". Composition - diagonal grid. Structure - damask on tabby base.</p>
6			<p>Mat Основная ткань Composition - diagonal grid. Structure - damask on tabby base.</p>



Fig. 2. Fabric with “tree” pattern (Photo by the Author).



Fig. 3. Fabric with “cloud” pattern (Photo by the Author).



Fig. 4. Fabric with the “texts” pattern, the discs (Photo by the Author).



Fig. 5. Fabric with the “texts” pattern, the trefoil (Photo by the Author).

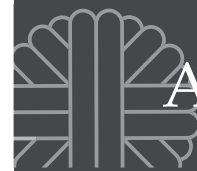

The design system of the fabric with “drop-shaped medallions” cannot be determined since this fabric is used for trimming and survives only in small pieces.

Weaving pattern

The weaving technology was studied by microscopic methods with the use of the optical microscope “MBC-10” at 20-100X magnifications.

Besides simple tabby fabrics of silk and cotton fibres, the find yielded a damask fabric where the design is introduced by substitution of the warp twill 3:1 with a Z-twist by the weft twill 1:3 with an S-twist. The remaining seven fabrics can be regarded as brocades since they include gilt threads in their structure. These fabrics can be divided into three groups according to the structure of weaves: weft-patterned on the basis of tabby, brocaded on the basis of tabby and lampas.

The weft-patterned group includes three fabrics, namely those with “trees”, “small clouds” and “birds.” All of them are based on tabby weave and have a warp and two systems of weft threads, the basic and the brocaded, the latter made with gilt threads (Table 5). A fabric with “drop-shaped medallions” was assigned to brocaded fabrics on the tabby basis. The three remaining fabrics are lampases on the tabby basis (Table 6).

The distribution of gilt threads over the cloth

Irrespective of the type of weave, gilt threads in three fabrics run evenly through the entire cloth while in the other three they are arranged in stripes (Table 7). This characteristic reflects the economizing of resources in fabric manufacture. Clearly, the introduction of gilt threads by stripes leads to the economy of this expensive material. Thus, even thin stripes of seven rows (0.27 cm) without gilt threads, as is the case of the fabric with “texts”, enable one to save 168 meters of the expensive thread per running meter, amounting to the economy makes of 13.5 %.(1). The fabric with “texts” is visually homogenous without visible stripes. It can be surmised that a skilled craftsperson designed the pattern and achieved the visual effect of homogeneity with the minimum of expenditure. There is no such effect in two other fabrics where gilt thread also runs in stripes. Both “birds” and “small clouds” are positioned in pronounced stripes. They belong to a cheaper category of brocades.

Thread count

The analysis of fabrics (Table 7) has demonstrated that the lampas fabrics can be divided into two subgroups: those with high thread count and a more

complex pattern (double lozenge grid and “lamellar” grid) and those with low count and simple pattern (lozenge grid). The most complex fabric in this respect is the one with “playing animals”, while those with “texts” and “clouds” are simpler (Table 7), *i.e.* lampases have a more complex structure of decoration than the weft-patterned ones.

Ground weave and pattern

The gilt pattern area naturally prevails or is equal to that of the silk ground in brocades. Gilt threads, however, can be used not only to form the pattern but also for the ground. In this case the pattern is formed by thin lines of the warp. Among six brocades only the fabric featuring “playing animals” has a gilt ground. The ground of other fabrics is either red or brown. It is interesting that the ground colour does not depend on the weave, *i.e.* colour is not connected with either simple or complex structure of the fabric.

Piece dimensions and types of selvedge

It was not always possible to find selvedges and establish the piece width in the excavated textile. We succeeded in establishing the width of three fabrics. These are the fabric with “trees” (64 cm wide), with “texts” (48 cm wide) and with “birds” (56 cm wide). The lampas fabric with “texts” has the minimum width, while the weft-patterned fabric with “trees” is the widest. Five fabrics yielded two types of selvedges: that with a vertical gilt stripe and cut off weft threads, and the common one where the gilt weft-threads turn back before the selvedge and do not take part in its formation. The second type is present in all three weft-patterned fabrics, while the first one can be seen only in the two lampas fabrics. No selvedges have survived in the fabric with “playing animals”.

Quality of fabrics

The category of silk fabric quality is purely conventional and adopted here solely for the small group of fabrics examined. No statistical data necessary for an in-depth study of this topic have been collected. The distinction between high- and poor-quality fabrics is, however, important for the textile analysis.

The quality of the finished fabric depends on the quality of raw materials and on the execution of the sequence of weaving operations. We analyzed the thread quality, *i.e.* the presence of bulges, the entanglement of fibres, and the evenness of twist and thickness along the thread, for six brocades. Such weaving errors as the end down are indicative of poor raw material. Dyeing technique and the



Schematic relationship of ground and pattern weft binding		Commentary																																																																																										
<table border="1"> <tr><td>4</td><td></td><td></td><td>■</td><td></td><td></td><td></td><td></td><td></td><td></td><td></td><td>■</td></tr> <tr><td>3</td><td></td><td>■</td><td></td><td></td><td></td><td></td><td></td><td></td><td>■</td><td></td><td></td></tr> <tr><td>2</td><td>■</td><td></td><td></td><td></td><td></td><td></td><td></td><td>■</td><td></td><td></td><td></td></tr> <tr><td>1</td><td></td><td></td><td></td><td></td><td></td><td></td><td>■</td><td></td><td></td><td></td><td></td></tr> <tr><td></td><td>1</td><td>2</td><td>3</td><td>4</td><td>5</td><td>6</td><td>7</td><td>8</td><td>9</td><td>10</td><td>11</td></tr> </table>	4			■								■	3		■							■			2	■							■				1							■						1	2	3	4	5	6	7	8	9	10	11	<p>Fabric with "trees" Ground – tabby Pattern – binding 1:7 in Z direction.</p>																															
4			■								■																																																																																	
3		■							■																																																																																			
2	■							■																																																																																				
1							■																																																																																					
	1	2	3	4	5	6	7	8	9	10	11																																																																																	
<table border="1"> <tr><td>6</td><td>■</td><td></td><td></td><td></td><td></td><td></td><td>■</td><td></td><td></td><td></td><td></td></tr> <tr><td>5</td><td></td><td>■</td><td></td><td></td><td></td><td></td><td></td><td>■</td><td></td><td></td><td></td></tr> <tr><td>4</td><td></td><td></td><td>■</td><td></td><td></td><td></td><td></td><td></td><td>■</td><td></td><td></td></tr> <tr><td>3</td><td></td><td></td><td></td><td>■</td><td></td><td></td><td></td><td></td><td></td><td>■</td><td></td></tr> <tr><td>2</td><td></td><td></td><td></td><td></td><td>■</td><td></td><td></td><td></td><td></td><td></td><td>■</td></tr> <tr><td>1</td><td></td><td></td><td></td><td></td><td></td><td>■</td><td></td><td></td><td></td><td></td><td>■</td></tr> <tr><td></td><td>1</td><td>2</td><td>3</td><td>4</td><td>5</td><td>6</td><td>7</td><td>8</td><td>9</td><td>10</td><td>11</td><td>12</td></tr> </table>	6	■						■					5		■						■				4			■						■			3				■						■		2					■						■	1						■					■		1	2	3	4	5	6	7	8	9	10	11	12	<p>Fabric with "small clouds" Ground – tabby Pattern – binding 1:5 in S direction.</p>						
6	■						■																																																																																					
5		■						■																																																																																				
4			■						■																																																																																			
3				■						■																																																																																		
2					■						■																																																																																	
1						■					■																																																																																	
	1	2	3	4	5	6	7	8	9	10	11	12																																																																																
<table border="1"> <tr><td>6</td><td></td><td></td><td>■</td><td></td><td></td><td></td><td></td><td></td><td>■</td><td></td><td></td><td></td></tr> <tr><td>5</td><td></td><td></td><td></td><td></td><td></td><td>■</td><td></td><td></td><td></td><td></td><td></td><td>■</td></tr> <tr><td>4</td><td></td><td></td><td>■</td><td></td><td></td><td></td><td></td><td></td><td>■</td><td></td><td></td><td></td></tr> <tr><td>3</td><td></td><td></td><td></td><td></td><td></td><td>■</td><td></td><td></td><td></td><td></td><td></td><td>■</td></tr> <tr><td>2</td><td></td><td></td><td>■</td><td></td><td></td><td></td><td></td><td></td><td>■</td><td></td><td></td><td></td></tr> <tr><td>1</td><td></td><td></td><td></td><td></td><td></td><td>■</td><td></td><td></td><td></td><td></td><td></td><td>■</td></tr> <tr><td></td><td>1</td><td>2</td><td>3</td><td>4</td><td>5</td><td>6</td><td>7</td><td>8</td><td>9</td><td>10</td><td>11</td><td>12</td></tr> </table>	6			■						■				5						■						■	4			■						■				3						■						■	2			■						■				1						■						■		1	2	3	4	5	6	7	8	9	10	11	12	<p>Fabric with "birds" Ground – tabby Pattern – binding 1:1 in checkerboard fashion.</p>
6			■						■																																																																																			
5						■						■																																																																																
4			■						■																																																																																			
3						■						■																																																																																
2			■						■																																																																																			
1						■						■																																																																																
	1	2	3	4	5	6	7	8	9	10	11	12																																																																																
<p style="text-align: right;">A</p>	<p>Fabric with drop-shaped medallions A – face side of the fabric B – back side of the fabric</p>																																																																																											
<p style="text-align: right;">B</p>																																																																																												

Table 5. Schematic drawings of fabrics with brocade bindings.



Schematic drawing	Commentary
	<p>Gown 1 Trimming fabric with "clouds" Lampas with taffeta ground Ground warp/pattern warp = 4:1. Ground warp – double threads. Ground – 1:1 Ground weft/pattern weft = 1:1 Pattern – 1:2 (Z)</p>
	<p>Gown 2 Main fabric with "texts" Lampas with taffeta ground Ground warp/pattern warp = 4:1. Ground warp – double threads. Ground – 1:1 Ground weft/pattern weft = 1:1 Pattern – 1:2 (Z)</p>
	<p>Gown 2 Trimming fabric with "playing animals" Lampas with taffeta ground Ground warp/pattern warp = 4:1. Ground warp – double threads. Ground – 1:1 Ground weft/pattern weft = 1:1 Pattern – 1:2 (S)</p>

Table 6. Schematic drawings of bindings in lampas fabrics.

Textile pattern	Binding	Pattern design	Gilt threads	Distribution of gilt threads	Rapport size (cm)	No. of elements*	Size of element (cm)	Ground weave/pattern	Ground weave thread count
"trees"	damask	diagonal grid	flat	entire cloth	1x2	1	1x1	silk/gilt thread	45/17
"small clouds"	damask	diagonal grid	flat	stripes	2x1	1 (+)	1x1	silk/gilt thread	52/16
"birds"	damask	diagonal grid	flat	stripes	3.5x3.5	1 (+)	1.5x2	silk/gilt thread	50/15
"clouds"	lampas	diagonal grid	spun	entire cloth	3x3	1	2x3	silk/gilt thread	38/13
"texts"	lampas	Complex diagonal grid	spun	stripes	8x4.5	1(+)	1x1 2.5x2.5	silk/gilt thread	48/26
"playing animals"	lampas	"lamellar" grid	spun	entire cloth	4x8	3	1.5x2.5 2x2 2x2	gilt thread /silk	54/20

* - (+-) indicates that this element has both direct and mirror image.

Table 7. Characteristics of brocaded textiles.



execution of the pattern also bear witness to the fabric quality. Thus, the depiction of birds in the cushion fabric is clearly seen in one direction and only with difficulty in the other. After summing up all these characteristics the fabrics were divided into two categories. The fabrics with even warp and weft threads having no pronounced defects, whose cloth is smooth and without errors and whose design is clear-cut were assigned to the high-quality group. The fabrics with mostly even warp threads and defective weft threads showing high fluctuation of thickness, whose cloth abounds in errors and whose design is confused are regarded as being of inferior quality. Lampases were assigned to the high quality group and weft-patterned fabrics to that of inferior quality. Differences in quality can also be distinguished within the first group. However, as stated above, we have only given a broad outline of the relevant study that requires a large amount of excavated textiles for comparison.

Conclusion

The archaeological record is, together with the written, iconographic and ethnographic sources, one of the pillars supporting the reconstruction of costume and visualization of the past.

The textiles and garments from Burial 93 of Maiachnyi Bugor I cemetery demonstrate that:

- Burial took place in winter as the deceased wore several types of warmth-keeping clothes;
- The same fabric type was used to manufacture a variety of garments;
- Clothes were made locally, possibly in the household;
- Fabrics previously used in other garments were reused for minor trimming details.
- Of fundamental importance is the question of the provenance of brocades. Let us turn to the fabric bearing benedictive Turkic inscriptions in Uighur characters, *i.e.* the main fabric of Gown 2. The areas of East Turkestan inhabited by the Uighur have yielded hundreds of Turkic texts in Uighur characters dating from the 8th to the 18th centuries AD. These are primarily business documents, letters and mainly fragments of Buddhist, Christian and Manichaean texts (Morozov 2006, 14). It appears therefore that the fabric with “texts” could have been manufactured in the East Turkestan where the famous cemetery of Astana yielded many high quality fabrics (Lubolesnichenko 1994, 79). As discussed above, the fabric with “texts” shows a complex pattern and a complex design, a skillful calculation of materials needed and can be regarded as originating from a centre with well-developed weaving traditions. The fabric

with “clouds” has certain common traits with that with “texts,” in particular selvages. It is possible that these two silks were manufactured in the same production centre.

– The weft-patterned fabrics of inferior quality could have been manufactured either in a centre with well-developed weaving traditions or in a newly-founded centre, for example in the Volga delta where weavers from Central Asia were settled (Müller-Christensen 1955, 30, 31).

– The brocaded fabric has numerous analogies to Chinese textiles. The dyestuff composition also implies Chinese manufacture.

– The red damask fabric shows a characteristic Chinese design. Its unstable dye, however, gives ground to doubt that it was manufactured in a major textile centre. On the other hand, the mordant could lose its durability after a long exposure to adverse conditions.

Acknowledgments

We thank Dmitrii Morozov who kindly attributed and translated the Uighur texts.

Notes

1. A calculation of the saving of gilt threads in the fabric with “texts”, pattern unit 0.8 cm: The unit has four stripes comprising seven rows of wefts without gilt threads each. Thus, every unit has 28 rows without gilt threads. The unit fits 12.5 times in a running meter. Thus, a running meter of the fabric comprises 350 rows without gilt threads. The width of the weaving piece being 48 cm, it makes up 168 m. It is the length of the gilt thread that was not introduced into the fabric by leaving thin stripes of the base cloth between decorative elements. Thread count being 26 weft-threads to the centimeter we have 2600 rows to the meter. We multiply the number of rows by the width of the fabric and get 1248 meters. It is the length of gilt threads that would have been spent in the case of their use over the whole area of the weaving piece one meter long. As it appears from the proportion 1248 m – 100%, 168 m – x %, 168 meters make up 13.5 % of the whole length. Thus, the introduction of gilt threads in stripes provides a considerable economy of gold.

**Bibliography**

Cardon, D. (2007) *Natural dyes. Sources, Tradition, Technology and Science*. Archetype Publications. London.

Golikov, V. P., Semikin, V. V., and Zharikova, Z. F. (2010) Исследование красителей и технологии крашения коптского текстиля в коллекции ГМИИ им. Пушкина [A study of dyestuffs and dyeing technology of Coptic textiles in the collection of the Pushkin State Museum of Fine Arts]. In O. Lechitskaia, *Коптский текстиль*. [Coptic Textiles]. Moscow.

Gold, Silk, Blue and White Porcelain (2005) *Fascinating Arts of Marco Polo Era*. Hanzhou.

Jaro, M. (1998) Differences in manufacturing technique, usually neglected, with the description of mediaeval metal threads made of metal coated organic material. Some remarks on the basis of scientific examinations. In R. Varoli-Piazza (ed.), *Interdisciplinary Approach about Studies and Conservation of Medieval Textiles* [Approccio Interdisciplinare allo Studio e alla Conservazione dei Manufatti Tessili d'Età Medievale]. Convegno-Interim Meeting ICOM-CC, Palermo, 22-24 Ottobre 1998. Rome.

Lantratova, O. B., Golikov, V. P., Orfinskaya, O. V., Vladimirova, O. F., and Egorov, V. L. (2002a) Исследование уникальных археологических памятников из собрания Государственного Исторического музея – комплексов одежд XIII-XIV вв. [Investigation of unique archaeological monuments from the collections of State Historical Museum – costumes of 13th-14th c. CE]. Moscow.

Lantratova, O. B., Golikov, V. P., Orfinskaya, O. V., Aliyev, A. D., and Payushina, O. V. (2002b) Экспериментальное исследование техники изготовления золотных нитей в золотоордынском текстиле XIII-XIV из собрания ГИМ (Experimental investigation of manufacturing technique of gold threads in the Golden Horde textiles from the collections of State Historical Museum). In VI Научная конференция «Экспертиза и атрибуция произведений изобразительного искусства» 2000 [VI Scientific Conference "Expertise and Attribution of Art Work"]. Moscow.

Lubo-Lesnichenko, E. I. (1994) *Китай на шелковом пути* [China on the Silk Road]. Moscow.

Morozov, D. A. (2006) Уйгурская запись в древнерусской рукописи [Uighur writing in Old

Russian manuscript] In *Памятники культуры. Новые открытия. Письменность. История. Археология. Ежегодник 2004* [Cultural Monuments. New Discoveries. Writing. History. Archaeology Annual 2004]. Moscow.

Müller-Christensen, S. (1955) *Gewänder des Mittelalters (tent. Cat.)*. München.

Mys'kov, E. P. (1995) О некоторых типах головных уборов населения Золотой Орды [Certain types of headdresses of the Golden Horde population]. *Rossiiskaya arkhеologiya*, 2, 36-43.

Orfinskaya, O. V. (2001) Раннесредневековый текстиль из коллекции Карачаево-Черкесского музея-заповедника [Early Medieval textiles from the collections of the Karachai-Circassian Museum]. PhD Thesis, Moscow.

Orfinskaya, O. V., Golikov, V. P., Lantratova, O. B., and Rudakov, V. G. (2006) Исследование нескольких деталей женского костюма из захоронения золотоордынского периода на могильнике Маячный бугор – I [Investigation of a few female costume elements from the Golden Horde period burial at Maiachnyi Bugor I cemetery]. In *Город и степь в контактной евро-азиатской зоне. Тезисы докладов III Международной научной конференции, посвященной 75-летию со дня рождения Г.А. Федорова-Давыдова (1931 - 2000)* [City and steppe in the Eurasian contact zone. Acts of the III International Scientific Conference dedicated to 75th birthday of G. A. Fedorov-Davydov (1931-2000)]. Moscow.

Vollmer, J. (2001) *Ruling from the Dragon Throne: Costume of the Qing Dynasty (1644-1911)*. Berkeley, CA.

Yerusalimskaya, A. A. (1992) *Кавказ на шелковом пути. Каталог выставки* [Caucasus on the Silk Road. Exhibition Catalogue]. St. Petersburg.

Шелковый путь (2005) *5000 лет искусства шелка* [Road of Silk: 5000 Years of the Art of Silk]. Moscow.

Corresponding author: Olga Orfinskaya
orfio@yandex.ru



Karen-Hanne Stærmose Nielsen

So simple and yet so complicated: A journey to Armenia to study a prehistoric warping method

Introduction

An unusual photograph caught my eye when reading the newsletter from the Danish Mission East in Copenhagen, Denmark (Hartzner 2010). It depicts three young people in front of a large loom placed at a slight angle (Fig. 1). The loom is almost empty, but the way the young people's hands are positioned reminded me of some of my own work situations, but also recalled scenes from the famous antique frieze from the Forum of Nerva in Rome (Blanckenhagen 1940, pl. 40-41), where, among others, two women are depicted probably in the process of warping a tubular weave. But what are the seated persons from Armenia (and Rome) doing at the lower part of the loom? This could not be deduced from the photograph, and although I had an assumption about this I wished to have this confirmed.

On enquiring with Mission East, a Danish aid organization which sponsors and supports, in cooperation with the Armenian government, the establishment of weaving schools or workshops for disabled children and young people in Armenia, I was informed that the photograph was taken at one of these schools to which the young people were connected. At the same time, a trip to Armenia was being organized by Mission East which would enable me to visit the workshop myself. The temptation was too great and in September 2010 I went to Armenia to, among others, visit the weaving schools.

The Prequel

In the course of 1939-1946, the pioneering Danish textile scholar, Margrethe Hald undertook a detailed investigation and analysis of textiles from Danish bogs and Danish Iron Age graves and settlement sites. This

resulted in her doctoral thesis, *Olddanske Tekstiler* published in 1950 (Hald 1950; 1980). During her work Hald analysed "a curious piece of textile": a cylindrical or tubular-shaped garment recovered in 1896 in the bog of Huldremose, Denmark, measuring 1.68 m in height (weft direction) and 2.64 m in circumference (warp direction) (Hald 1980, 53; Mannering et al. 2010). In its shape and possible method of wearing, it closely resembles the Greek peplos depicted on vases



Fig. 1. The making of a tubular warp for a carpet at a charitably-funded weaving school for disabled youngsters in Armenia 2010 (Photo: Hayrapet Hoveseptyan Mission East, Yervan Armenia).



from the 5th century BC.

The reason why Hald called this piece “curious” was due to the vertical feature which ran across the entire width of the tube. A closer examination revealed that it was not a seam, but consisted of a wool cord around which the warp threads were wound as they alternatively came from above and below the cord (Fig. 2). Hald called the cord a warp-lock. It functions like a zipper, keeping the fabric in its tubular shape. When pulled out, the warp-loops from the two ends of the textile would separate and thereby open the fabric and make it flat. Need one name the sheer number of useful advantages of this procedure during warping and weaving?

However, let us first return to Hald, who, amazed by her discovery of the warp-lock asked (Hald 1980, 211): “Is a loom with two beams known, where the warp is laid round the beams and where the turns of the warp along both transverse edges pass round a cord stretched between the two beams?” Hald illustrated this question with a diagram which in principal shows both the manner of warping and the tool with which she imagined a tubular weave could be produced (Fig. 3).

Subsequently, as Hald continued her investigation she encountered many more examples of open or closed tubular weaving in the Danish Early Iron Age textile material that had yet to be examined. Regrettably, the political situation in Europe (1940-1945) prevented Hald from visiting museums abroad to look for parallels, but through literature studies Hald discovered that the same warping methods were used by the Indians of South America and the north-western USA (Nordenskiöld 1919; Olson 1928). The same principle was found in Tibet as well (Montell 1934). Montell had observed and photographed a woman seated on the ground with a ca. 0.50 m wide tubular warp on a loom with one of the beams attached to the waist; the other beam is – frustratingly – out of the picture. Furthermore, Hald added in a postscript to the conclusion of the manuscript of *Old-danske Tekstiler* that an important publication had come to her attention (Hald 1950, 486). In the book *The Vertical Loom in Palestine and Syria* by Grace M. Crowfoot (Crowfoot 1941), tubular weaving from Palestine, Syria, Turkey and Greece was discussed, and it documented that warping in these areas was done according to principles still known to us today (Fig. 4). “Thus, as expected, even before this present work goes to press” wrote Hald, “information on tubular weaving...will increase” (Hald 1950, 403). The volume of this increase is seen in the package of written paper simply tied with a string that was found in 1984 among Hald’s literary remains. An incomplete

manuscript and a large amount of photographs bear witness that a book on tubular weaving around the world was in progress. Papers dating from ca. 1952 until about a year before Hald’s death in 1982 were found. The manuscript has now been handed over to the Danish National Research Foundation’s Center for Textile Research (CTR) in Copenhagen.

Thoughts on weaving techniques

The diagrams by Hald, as well as by Nordenskiöld and Olson, lead us to understand that the ball of warp yarn goes continuously around the upper and lower beam with a turn around the tightly fastened warp-lock. Crowfoot’s diagram (see Fig. 4), on the other hand, shows the ball of warp yarn lying on the ground with a warp loop going up and led around and hooked in over the warp-lock. This seemingly little, yet, in reality, large change in the warping procedure necessitates the warp-lock to be a thin, rigid stick fastened only at one side of the loom.

Later in 1960, Hald also had the opportunity of studying weavers in Syria and Lebanon who, among others, used the tubular warp method to weave lengths of goat hair for their famous black tents. The warp could have a substantial length. For instance, a loom was seen in an alley, set up with a third extra beam up to about 10 m away. The resulting textiles could thus be up to 20 m long. Hald actually brought home to the National Museum of Denmark such a loom and warp from her trip (Paulli Andersen 1966-67). It would be of great interest to see this loom set up and exhibited in the museum someday.

In the article describing her fascinating travels Hald (1961, 112) writes: “An iron rod is placed along the lower beam in front of the loom, so that its right end is free and movable. The weaver sits in front of the loom with the legs placed in the pit beneath the loom and ties the warp thread to the rod’s left end. He pulls out a loop from the ball of warp yarn, and raises it up towards the top beam, and a boy then snatches this with a wooden hook and brings it around the third beam behind the loom and forward again. The weaver receives the loop beneath the lower beam, pulls it upwards and in over the iron rod. With the thread from above, he again forms a loop which is laid in over the rod and finally he makes a third loop for the boy to snatch with his hook once again.”

Back to Armenia

Now the explanation for why I had to go to Armenia may begin to be apparent. It was to see how, in a state that had only been independent for 20 years, a new generation of carpet weavers were being taught a craft that is several thousand years old. In the course

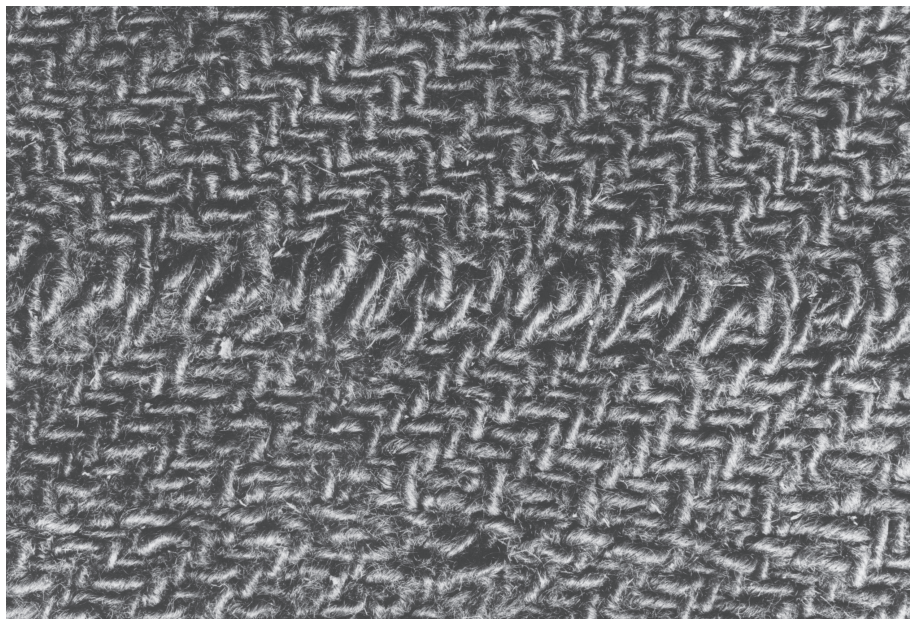

Fig. 2. The warp-lock in the Huldremose tubular textile (National Museum of Denmark Mus. no. D3505). The wefts are those parallel to the lock. The area above the warp-lock is the beginning of the weave and the area below is the end of the weave (Photo: Roberto Fortuna, the National Museum of Denmark).

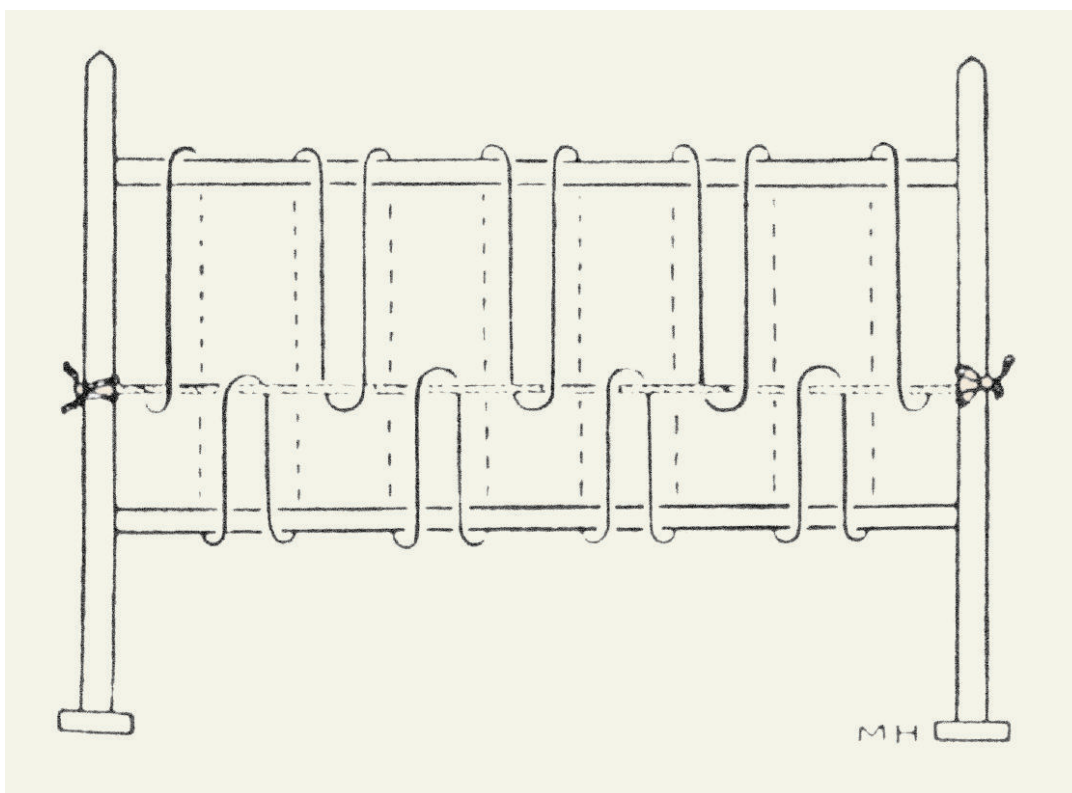

Fig. 3. A proposal for an upright tool with two beams as envisaged by Hald before 1950 for the possible making of a tubular warp utilizing a warp-lock (After Hald 1980, fig. 213).



of one day, I managed to see, and try, their inherited but also adapted for the purpose warping procedure. By imagining the warping process which was used in the Iron Age in Scandinavia, e.g. in the Huldremose textile, and comparing it both with the way in which the lengths of goat hair in Syria and Lebanon were warped, and with the warping I myself observed in Armenia in 2010, we see a technique which gradually evolved and through hard won experience and specialisation has spread and survived until today. Instead of repeating Hald's words from Syria and Lebanon (Hald 1961, 112), I have made a step-wise sketch of the different phases of the warping procedure (Figs 5 and 6). If you follow the warp thread in every step on the sketch, you will gain a better understanding of this process.

The loom and the warping process remained almost

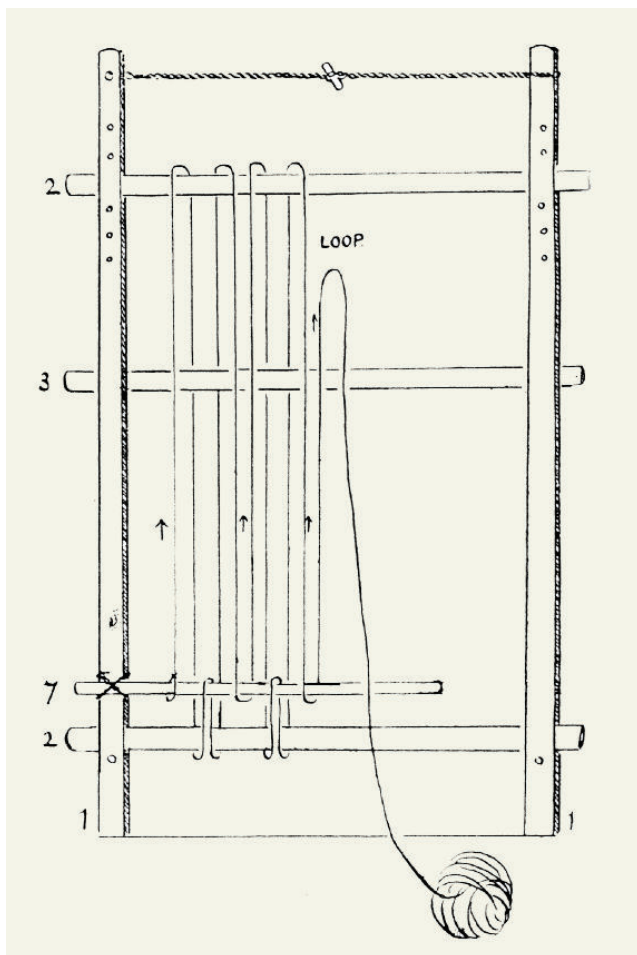

Fig. 4. This sketch by Crawfoot reveals that the warp-lock is replaced by a thin wooden stick fixed in one end and left free at the other end (After Crawfoot 1941, pl. XIV).

unchanged throughout history, and only few “improvements” have been undertaken in Armenia: the warp-lock, usually a thin and round stick, is replaced here by a wooden plank of about 1 cm wide and 5 cm high and as long as the width of the planned carpet. Various technological reasons in warping, weaving and finishing the plaited borders of the carpet may have necessitated this modification.

It is worth noting that this warp-lock plank is not firmly attached to the lower beam at any point. The reason being that it has to be able to “travel” all the way around both beams in the loom, namely when the area that is woven has to be pulled downwards after 20-30 cm of weaving. This manoeuvre is done by loosening the wedges that keep the lower beam down, and as the beams are rounded and smooth this action will cause no problem. I was also impressed by the practised and skilful way of laying each warp thread precisely just as taut as the neighbouring threads, which my young teacher, Erich showed me.

A-J-O warps

I came all the way from Denmark to Armenia just to see how the warping was done. Luckily, I managed to observe a little more however. Several pupils showed me how they tied the carpet knots on their small square test carpets. Three or four of them sat besides each other at the big looms, so that in this way all movements and actions were made as if on the scale of “real life”. They had a little L-shaped iron comb with which they hammered down one row of knots and two subsequent ground weave wefts in the direction of the warp-lock.

Erich, my young guide, was especially interested in seeing the pictures I had brought with me of the various types of looms from around the world. Just imagine that one could weave both up and down, and even use oneself as a human “warp fastener” with the help of a belt tied around the hips and a strap around the toe! His surprise and enthusiasm tempted me – now using pen and paper – to try to explain to him that, instead of the impossible task of dividing the weaving tools (looms) themselves into different types, it would be easier to categorise the looms according to technological criteria, e.g. how the respective warps are constructed, fastened and function in a loom.

Let us call the warp of the warp-weighted loom an A-warp (the letter A symbolizing an upper beam with an open warp beneath) and a tubular weave warp with or without a lock for an O-warp (with the threads running in two layers in a ring around the



two beams) and a warp stretched in a single layer between the two beams (just like a film roll in an old-fashioned camera) could be called a J-warp (Stær-mose Nielsen 1999, p. 106).

These three ways of warping are so different that they can neither be confused nor be derived from each other and thus are equally original. In other words: all the loom types around the world are dependent on one of these three warping systems. From ancient times, both the J and O warps have been operated in vertical as well as in horizontal, and even, in a slanting position. Furthermore, the A and O warps have moved almost in a closed circuit in contrast to the J-warp, which is the only one that had the potential to develop into the basic idea of a treadle loom. (It is noteworthy that J warps are workable only in a horizontal or approximately horizontal position, because the foot is the one that opens the so-called shed by means of a downward drive in the stretched warp threads).

History shows us very basic treadle looms that utilize features from other primitive looms. Examples are: pits for feet and treadles; cord around the weaver's waist to keep the front beam; a peg driven into the ground far away from the weaver to keep the bundle of warp threads taut. This last idea or even invention is done, among other things, to avoid the constant problematic coiling up of the long warps on a beam (Stær-mose Nielsen 1999, figs 78 -81).

The Farewell

The circle around us had gradually become closer and as our time was drawing to an end, we had to say goodbye to the Armenian teacher, the youngsters and the interpreter. I had enjoyed to the uttermost the respectful working atmosphere that prevailed throughout the weaving schools, both for the handicraft itself, which the pupils had learned completely from scratch, and for the individual pupils who were burdened with various problems and disabilities. This atmosphere no doubt was in contrast to what one often hears about carpet factories using child labour, providing poor conditions for the workers, and using inferior materials resulting in poor quality carpets.

I was imbued with a feeling of having contributed a little in return for having had the opportunity to come and study a prehistoric warping method in action for which I am truly grateful.



Fig. 5. One example from the warping process that I learnt by observing and trying it myself (see Fig. 6, step 6). Note that the position of the arms and hands of the young pupils are typical and distinctive for this almost worldwide method of tubular warping. The young girl, who is standing at the beam throughout the entire action, has just handed down the loop to the weaver, Erich, who then takes the loop behind and under the beam whereupon step 7 in Fig. 6 shows the loop out in front and ready for steps 8 and 9. These two steps (8 and 9) are the most complicated and call for accuracy.

Before completing step 9, the weaver has to pull the warp thread (with the arrow) downwards by which the big loop around the warp-lock will be tightened as in step 10. (Photo: Kirstin Lee Bostelmann).

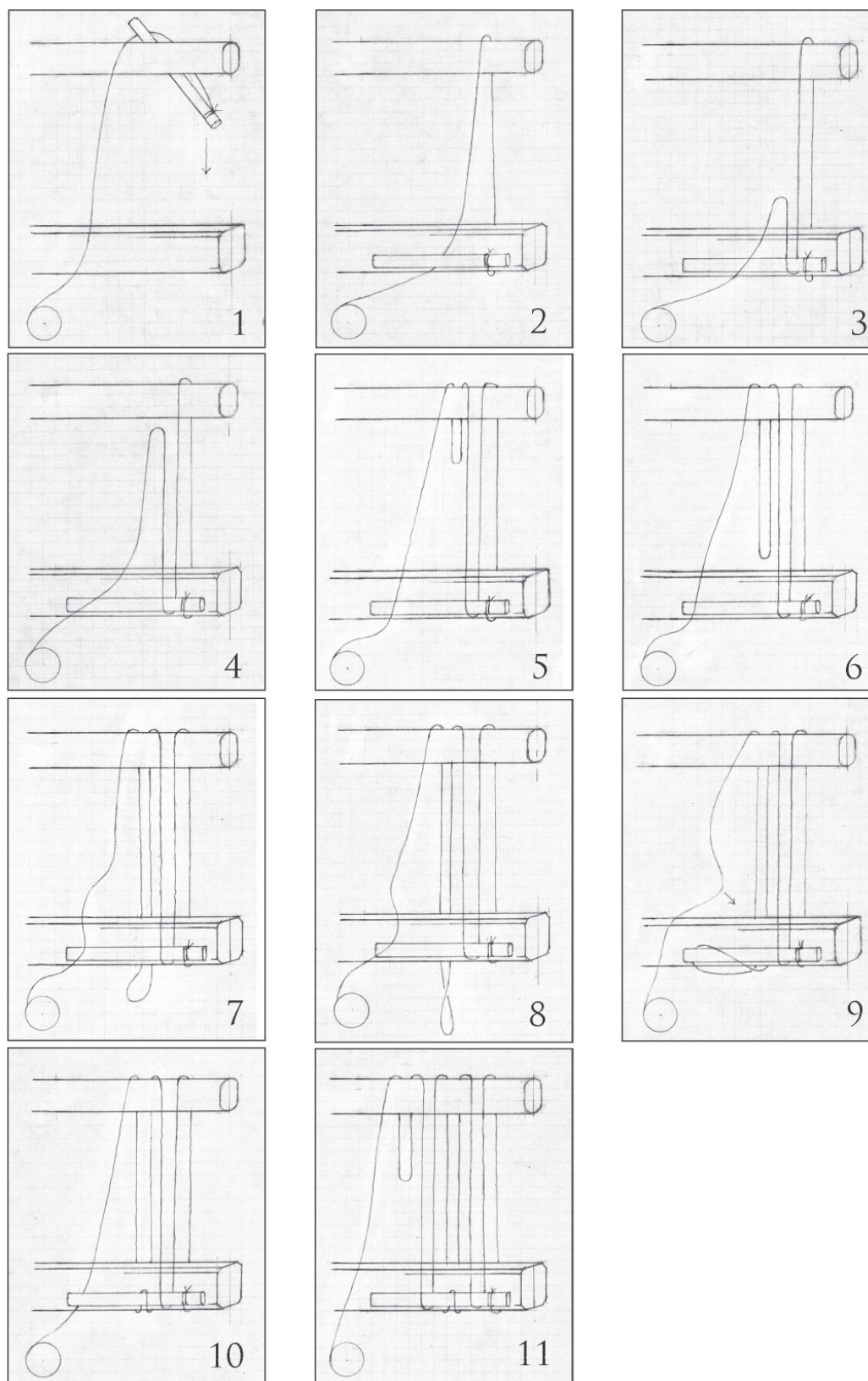

Fig. 6. Sketch showing the stepwise sequence of the tubular warping with a warp-lock. (Drawing: Karen-Hanne Stærmosse Nielsen).



Acknowledgments

I would like to give my most heartfelt thanks to the VELUX Fund and CTR for their financial support which enabled me to travel to Armenia. My gratitude also goes to Mission East in Yerevan (and Copenhagen) for helping me with the contacts to the weaving school: Yerevan State Humanitarian College and Republican Special School number 2. Finally, many thanks to Kirstin Lee Bostelmann, Mission East, Yerevan who took the official photographs during my study visit.

Translated by Cherine Munkholt, CTR.

Bibliography

Blanckenhagen, P.-H.V. (1940) *Flavische Architektur und ihre Dekoration untersucht am Nervaforum*. Berlin.

Crowfoot, G.M. (1941) *The Vertical Loom in Palestine and Syria*. *Palestine Exploration Quarterly*.

Hald, M. (1950) *Olddanske Tekstiler*. *Nordiske Fortidsminder V*. København.

Hald, M. (1961) *I Libanons Skygge*. *Nationalmuseets Arbejdsmark*, 108-116.

Hald, M. (1980) *Ancient Danish Textiles from Bogs and Burials*. *Publications of the National Museum. Archaeological-Historical Series Vol. XXI*. Copenhagen.

Hartzner, K. (eds.) (2010) *Newsletter from Mission East, Issue 3*. Copenhagen.

Mannering, U., Possnert, G., Heinemeier, J., Gleba, M. (2010) *Dating Danish textiles and skins from bog finds by 14C-AMS*. *Journal of Archaeological Science* 37, 261-268.

Montell, G. (1934) *Studier i asiatisk tekstilteknik*. Ymer.

Nordenskiöld, E. (1919) *An Ethnographical Analysis of the Material Culture of the Indian Tribes in the Gran Chaco*. *Comp. ethnogr. stud. I*, Göteborg.

Olson, R. L. (1928) *The Possible Middle-American Origin of the NW-Coast Weaving*. *American Anthropologist IV. New Series Vol. 31*, 118-120.

Paulli Andersen, M.K. (1966-67) *Håndarbejdets Fremme nr. 4*, 32 årg.

Stærmose Nielsen, K.-H. (1999) *Kirkes Væv. Opstadvævens Historie og nutidige Brug*. Lejre.



Penny Walsh

The Medieval Dress and Textile Society Meeting, London, 5 March 2011

The Medieval Dress and Textile Society (MEDATS) was founded in London in 1991 with the aim of providing a forum for all those interested in European clothing and textiles secular or sacred - roughly from the end of the Roman Empire in western Europe until about AD 1600.

The study day and themed workshop 'Making it: Textile Technologies in Medieval Europe' held at the Museum of London on March 5th 2011, explored the technical knowledge and practical skills required to produce yarn and textiles in north-west Europe during the period from the 5th to 15th century AD. The day was planned to be an interdisciplinary exchange of research between experimental archaeologists, historians and practitioners and the MEDATS was delighted to welcome 11 speakers and demonstrators from Britain and also from Holland and Scandinavia where there has been extensive study of this aspect of textile history.

In her opening overview Gale Owen-Crocker outlined the series of technological changes to textile tools and machinery during the period and each subsequent speaker, in chronological sequence, dealt in greater detail with these changes to textile technology.

A PowerPoint presentation in the Activity Centre showed eight stages of woollen cloth production from the 15th century stained glass panels of the Cloth Worker's chapel of the collegial church of Notre Dame, Semur-en-Auxios.

In their respective papers Ruth Gilbert and Alan Raistrick outlined the technological changes in yarn spinning during the medieval period. Ruth also demonstrated fine thread spinning on a distaff and a drop-spindle using both linen flax and combed wool. Alan Raistrick, a retired engineer, explained the technical advances of spinning wheel components which enabled enormous increases in yarn production in the subsequent period. The 'Great Wheel', demonstrated by Ann Markwick, was an

important step in this development. The obvious massive size and weight of the machine meant it required great strength and control.

The lost skills and extended processes of fibre preparation were explained by Anton Reurink in a paper describing a project to recreate medieval broadcloth. He explained how wool comb warmers, replicated using contemporary illustrations, improved the speed at which the fibres could be prepared. It was therefore interesting to see Katy Owens demonstrating wool combing using similar combs. Medieval weaving technology was outlined by three papers and demonstrated by Jo Wexler, a tablet weaver who has researched and made several looms to create the structure and patterns of tablet-woven bands, and Glenys Crocker, who has graduated from weaving tabby to four-shed twill on her impressive warp-weighted loom.

Three speakers outlined developments in loom technology: Anna Nørgård who has completed several practical research projects at the Viking Ship Museum in Roskilde, Denmark using the upright loom; Kathrine Brandstrup (who also demonstrated naalbinding or knotless knitting) who charted the development of the loom from AD 1100 to 1500; and finally Nat Alcock, who described a project in Coventry to recreate a weaver's house, loom and weaving tools from evidence in local wills and records from AD 1540, by which time the loom was horizontal as evidenced by pulleys and treadles found on the site.

The final question and answer session as well as discussions throughout the day had stimulated questions about the exact details of the way in which medieval textile tools might have worked. The demonstrations stimulated discussion about the level of craftsmanship and an assessment of how labour intensive the production of the highest level cloth would have been.

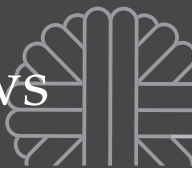

Ulla Mannering

XI Nordic-TAG, Session on Textile and Theory

28 April 2011, Linnæus University, Kalmar, Sweden

During the 11th Nordic TAG in Kalmar, Sweden 26-29 April Eva Andersson Strand, Ulla Mannering and Marie-Louise Nosch from the Danish National Research Foundation's Centre for Textile Research (CTR) organized a session on "Textile and Theory". The aim of the session was to demonstrate how theoretical approaches are applied to textile research and how textile researchers contribute to the theoretical discussion in various disciplines.

Eva Andersson Strand opened the session with an introductory paper giving several examples of how theory recently has been applied to textile research in general and especially how this aspect has influenced the research conducted at the CTR.

Johan Zimsen Kristiansen, an art historian who was a guest researcher at CTR in 2010, gave a very informative and inspiring paper on textiles and endangered languages, explaining the use of socio linguistic theory. Johan Zimsen Kristiansen then reported on a recent field trip among Navajo weavers and shepherders in the western part of the United States, where he has studied these endangered languages.

With her paper on "Textiles and animal skins; comparing materials in context", Susanna Harris from UCL, London discussed in depth the concept of Cloth Cultures which she is currently developing. Susanna Harris's starting point was that one of the reasons why textile research has a problem engaging with social theory is its focus on a single technology. Textile research privileges woven textiles: a technique of producing cloth on a loom from two intersecting thread systems. This approach allows excellent analysis of textile types and their mode of production, but does not readily incorporate

comparative materials. Instead by comparing the range of cloth-type materials including woven textiles, looping, netting, leather and fur as well as sheet metals and bark, cloth can be viewed in terms of values and social distinction both through time and across space.

Linda Hurcombe from the University of Exeter ended the session with the paper on "Intimate relations: the raw materials of clothing as landscape and event memories and sensory cues". Linda Hurcombe proposed that in the earlier prehistoric period there would be strong personal connections between collecting the resources and then making and wearing clothes. Clothing is intriguing from a theoretical perspective because it offers the chance to wear something for which there can be intimate memories of specific elements of the landscape of plants and animals. Furthermore the choice of how to process a skin, or the preparation of fibres alters textures, colours and smells. Thinking through the connections with the trees, plants and animals, and whether these are likely to be wild, tended, or domesticated resources, offers insights into attitudes to landscapes and to the sensory material cultures of the past. Linda Hurcombe demonstrated how different theoretically aware perspectives offer new ways of thinking about textiles.

As understood from the comments and questions following the papers, this session was an eye opener to many of the participants and hopefully the potent research field of textile and theory will be further discussed and challenged in the future. The papers will be published in the next ATN.

Marianne Bloch Hansen, Ulla Mannering and Frances Pritchard

NESAT XI, 9-13 May 2011, Esslingen, Germany

The 11th meeting of The North European Symposium for Archaeological Textiles (NESAT) was held in Esslingen. The conference were organized by Johanna Banck-Burgess competently assisted by Carla Nübold and Mariana Bauer, and we thank the whole team for some very inspirational and informative days in a very welcoming and pleasant atmosphere. The conference was hosted by Landesamt für Denkmalpflege Baden-Württemberg and during the four full days of the conference many different papers and posters were presented. It is not possible to mention all the excellent papers here, so we have just pointed out a few examples. Abstracts are available online on the NESAT website (www.nesat.org). The theme of the first conference day was methodical principles within the humanities and natural sciences held at the beautiful location of the Salemer Pflughof. The papers given demonstrated that this interdisciplinary approach entails many new

possibilities in our understanding and interpretation of the archaeological textile record with subjects ranging from color and fiber analysis to the use of iconographic sources.

The second day, continued with case studies applying methods of natural science in the study of archaeological material. The first paper of the day was on Virtual Technological Analysis of Neolithic textiles. Here it was demonstrated how virtual analysis can be used to reveal details that are otherwise invisible to the eye and how the method enable investigation into archaeological objects in a non-destructive manor. Later a paper on proteomics applied to wool was presented. This is a new method which aims at delineate differences within wool proteins. This is mostly related to modern wool but it has a big potential for the investigation of archaeological textiles in order to differentiate between the different properties that



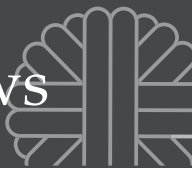

ancient wool might have had. In the afternoon the poster presentation took place at the Landesamt für Denkmalpflege. The posters will be published on the NESAT website in the near future.

Thursday the focus of the papers were on the presentation of finds from prehistory to modern times, and in the afternoon excursions was arranged for the participants with visits to either the Fashion Museum Schloss Ludwigsberg or the Celtic Museum Hochdorf.

The last day continued with the presentation of finds and the subject of textile production. The conference ended with a final discussion and after this the report from the NESAT committee. Among other it was announced that Lise Bender Jørgensen will stand down from the NESAT committee in order to make room for new NESAT committee members. Her decision was accepted with reluctance and regret by all the NESAT participants. Since the beginning of the NESAT conferences Lise Bender Jørgensen has been a catalyst for the NESAT organisation throughout its 30 years of existence. In addition to discovering

and encouraging new members from many different countries to take up textile studies, she has edited three of the proceedings, supported grant raising initiatives and undertaken many behind-the-scenes activities. Her papers have frequently been ground-breaking in their vision and she has ensured that theoretical approaches, experimental archaeology and craft practice have not been overlooked. During NESAT XI Lise Bender Jørgensen presented her latest collaborative research project, "Studying creativity in Bronze Age textiles" supported by the Humanities in the European Research Area in which many young textile scholars participate. We thank Lise Bender Jørgensen for being an inspirational and incomparable figurehead for the NESAT community, and look forward to many more ground breaking papers at future NESAT conferences.

The next NESAT will be held in Hallstatt, Austria in May 2014, organised by Karina Grömer and hosted by Naturhistorisches Museum in Vienna, Austria.

Dissertations

Tereza Štolcová (Comenius University in Bratislava, Slovakia) has been awarded a PhD for her thesis: *Vývoj výroby textilu a odevu v severnom Podunajsku od konca praveku po včasný stredovek (The development of textiles and clothing in the North Danube area during the late prehistory and early history).*

Kerstin Dross-Krüpe (Philipps-Universität Marburg, Germany) has been awarded a PhD for her thesis: *Textilproduktion in der römischen Kaiserzeit am Beispiel der Provinz Aegyptis.*

Recent publications

Kleidung im Mittelalter Materialien – Konstruktion – Nähtechnik; ein Handbuch,

by **Katrin Kania, Böhlau, 2010** (in German)

Leichtverständlich und fundiertgeleitet das vorliegende Handbuch die Leserdurch die komplexe Welt der mittelalterlichenKleidung. Die Grundlagen und Bedeutungen verschiedener Materialien, Näh-, Stich- und textiler Technik enwerden ebenso erläutert wie die Voraussetzungen, Grenzen und Möglichkeiten der Forschung. Eine Analyse der erhaltenen mittelalterlichen Kleidunger möglich die Darstellung der Entwicklungslinien in der Zeit von 500 bis 1500. Erläuterungen zur rekonstruierten Schneidertechnik des Mittelalters sowie ein ausführlicher, bebilderterkatalog der überlieferten Kleidungsstücke und Rekonstruktionszeichnungen vervollständigen das Handbuch. Damit liegt erstmals eine umfassende Übersichtvor, die für das Verständnis, die Rekonstruktion und die Erforschung mittelalterlicher Kleidung eine unverzichtbare Grundlagebildet.

ISBN-10: 341220482; ISBN-13: 978-3412204822

Price: € 67.90 [D] € 69.80 [A]

<http://www.boehlau-verlag.com/>

Purpureae Vestes III. Textiles y tintes en la ciudad Antigua, edited by **C. Alfaro, J-P.Brun, Ph. Borgard and R. Pierobon Benoit, Valencia: University of Valencia, 2011** (in various languages)

Proceedings of the Third Purpureae Vestes Symposium, held in Naples, Italy in 2008.

ISBN-13: 978-84-370-7960-8

Price: € 30.00

<http://puv.uv.es/>

War and Worship: Textiles from 3rd to 4th-century AD Weapon Deposits in Denmark and Northern Germany, by **Susan Möller-Wiering, Ancient Textiles Series Volume 9, Oxford: Oxbow Books, 2011**

War and Worship concerns textile deposits from the bog sites of Thorsberg in Germany and Nydam, Vimose and Illerup Ådal in Denmark. All four sites are well-known for containing a substantial amount of archaeological materials, particularly weapons, but they also contain, as integral parts of the weapon deposits, a smaller number of preserved textiles, which nevertheless constitute outstanding assemblages. With the exception of Thorsberg, publications dealing particularly with textiles from weapon deposits are almost non-existent. The textiles from each site are analysed, then compared to one another and described as a unit characterising the particular site. Comparisons are then made between the four sites, with emphasis on the overall context. A final chapter by Lise Ræder Knudsen analyses tablet-woven textiles in the deposits, a textile technique used to make bands, edges and borders. Although the state of preservation of the textiles at the different locations varies hugely, the research has extracted a large amount of information allowing conclusions on status, origin, function and role in the deposits to be drawn. The fabrics presented here were, unquestionably, consecrated textiles. They had been worn by the defeated foreign warriors during the battle and were considered worthy as sacrificial offerings to the gods. Some individual high-status textiles were perceived to have a value comparable to certain metal items. Others - probably the majority - were used for covering and wrapping other offerings for the subsequent sacrifice. All were committed to the lakes in a sacred act of remembrance to celebrate



victorious battles.

ISBN-13: 978-1-84217-428-9

Price: £30.00

<http://www.oxbowbooks.com/bookinfo.cfm/ID/90787>

***Wearing the Cloak: Dressing the Soldier in Roman Times*, edited by Marie-Louise Nosch and Henriette Koefoed, Oxford: Oxbow Books, 2011**

Wearing the Cloak contains nine stimulating chapters on Roman military textiles and equipment that take textile research to a new level. Hear the sounds of the Roman soldiers' clacking belts and get a view on their purchase orders with Egyptian weavers. Could armour be built of linen? Who had access to what kinds of prestigious equipment? And what garments and weapons were deposited in bogs at the edge of the Roman Empire? The authors draw upon multiple sources such as original textual and scriptural evidence, ancient works of art and iconography and archaeological records and finds. The chapters cover - as did the Roman army - a large geographical span: Egypt, the Levant, the Etruscan heartland and Northern Europe. Status, prestige and access are viewed in the light of financial and social capacities and help shed new light on the material realities of a soldier's life in the Roman world.

ISBN-13: 978-1-84217-437-1

Price: £25.00

<http://www.oxbowbooks.com/bookinfo.cfm/ID/90897>

***Ørnetæppet og andre silkefund fra Knud den Helliges helgenskrin i Odense Domkirke*,**

by Anne Hedeager Krag, Peter Kristensens Forlag, 2011 (in Danish)

[The Eagle Silk and other silks in the shrine of St. Canute in Odense Cathedral]

Contacts between Denmark and Byzantium, the Eastern Roman empire, in the 12th century are reflected in the silk finds from Odense. At present two rare patterned silk weavings are on display in the crypt of St. Canute, the Cathedral of Odense; one larger piece, red with a pattern of eagles and

a smaller yellow pillow with a motif of birds and crosses. Both are attributed to the reliquary shrine of King Canute the Saint, murdered in 1068 and canonised in 1100. Plausibly the silk textiles were gifts from Canute's widow Adèle, later married to the South Italian Duke Roger of Apulia. International research regards the silk finds from Odense to be highlights in a European context, and attribute them to the great Christian Byzantine Empire. Next to the shrine of King Canute is another shrine, probably that of Benedict, the king's brother. In this shrine are two monochrome yellow silk pillows, one short and another long. The book discusses the textiles from the two shrines. It presents new colour analyses of the silk textiles, as well as an interpretation of their motifs, style and use against a wider European background illuminated by the latest research.

ISBN: 978-87-7851-303-8

Price: DKK 198.00

<http://poulkristensensforlag.dk>

***Bronze Age Textiles: Men, Women and Wealth*, by Klavs Randsborg, Duckworth 2011**

Among its most prized objects, the Danish National Museum holds completely preserved woollen dresses, both female and male, from oak coffin graves of the early second millennium BC. These garments are matched in old age and superb preservation only by finds from Ancient Egypt. In the ancient civilizations of the Eastern Mediterranean, textiles were generally much more costly than foodstuffs, materials, animals, bronzes, and many other items; it is very likely that the same was the case throughout prehistoric Europe. In this study, Klavs Randsborg re-examines these and other Bronze Age textiles, along with related artefacts such as images and figurines, in the context of archaeological, ethnographical and historical information from Europe and beyond, to build up a picture of culture and society, work and wealth in the northern Bronze Age.

ISBN-13: 978-0-7156-4078-4

Price: £12.99

<http://www.oxbowbooks.com/bookinfo.cfm/ID/90196/Location/Oxbow>

Websites

<http://www.tabletweaving.dk>

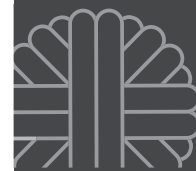

Lise Bender Jørgensen

Creativity and Craft Production in Middle and Late Bronze Age Europe

Creativity and Craft Production in Middle and Late Bronze Age Europe (CinBA) brings together partners from the Universities of Southampton, Cambridge and Trondheim, the National Museum of Denmark, the Natural History Museum of Vienna, Zagreb Archaeological Museum, Sagnlandet Lejre, Denmark and the Crafts Council, UK. It offers important insights into the fundamental nature of creativity by exploring a part of European history not influenced by contemporary concepts of art – the Bronze Age – looking at developments in the crafts: pottery, textiles and metalwork. It investigates objects as a means to understand local and transnational creative activities, investigating the development of decorative motifs and the techniques and skill used for these. It tracks these developments over more than a millennium within regions forming a north-south axis across Europe: Scandinavia, Central Europe and the Adriatic. In addition, links between ancient and modern creativity are explored through contemporary engagements with Bronze Age objects by modern craftspeople and the public.

CinBA is funded through HERA – Humanities in the European Research Area. HERA aims to strengthen the European voice in the Humanities by coordinating research activities and transcending historical limitations to develop new Europe-wide research agendas. The project started 31st May 2010 and will run to the end of May 2013.

The textile team is headed by Lise Bender Jørgensen (Principal Investigator), and is a collaboration between Norwegian University of Science and Technology (NTNU) and Natural History Museum of Vienna (NHM). Researchers involved in the project are Sophie Bergerbrant and Sølvi Helene Fossøy of the NTNU; from the NHM participate Anton Kern (Principal Investigator), Karina Grömer, Helga Rösler-Mautendorfer, and Johann Reschreiter. Antoinette Rast Eicher (ArcheoTex) and Lena Hammarlund

(Hammarlund Textile Studio) carry out fibre analyses and characterization of textile surfaces, while Regina Hofmann-de Keijzer and her colleagues at the Vienna University of Applied Arts are in charge of dye analyses.

Research is structured around 4 shared specific analytical concerns:

1) The qualities of materials: characteristics and particular potentials of each material. How did the innate qualities of each material inspire, guide and restrict the production of objects? What specific decisions were required to work with them? For example: How were complex textile surface designs accomplished in weaving?

2) Motifs and skills: investigation of the development of skill and motifs, and comparisons between the materials in terms of technical relationships and cross-material influences through the transfer of knowledge.

3) Spatial and temporal trends: tracing changes within and between materials in terms of the patterns identified under 1 and 2. How did the practice of each craft develop and how did changes in one region inspire imitations and developments elsewhere? For example, did patterned textiles develop independently in different parts of Europe and to what extent did designs in textile production were shared?

4) The perception of prehistoric craft today: How do different contemporary groups respond to the creativity embedded in prehistoric objects? How do modern craftspeople engage with such objects, interpret the decision-making processes required to make them, and use them as the basis for their own creativity? For the public, does participating in the reproduction of prehistoric objects inspire people to



think about how things are made and challenge their understanding of creativity? Furthermore, how does the classification of an object as a souvenir affect its understanding?

The study of the innate qualities of the raw materials and how they influence the appearance and properties of the textiles will be based on the fibre analyses and characterisation of surfaces, and will be followed by an investigation of decorative features, how they interplay with textile surfaces and whether signs of cross-material influences can be detected. This is to be taken further by investigating temporal and spatial trends. Stitches, sewing and embroidery are investigated by Helga Rösel-Mautendorfer in her PhD project that is part of the CinBA research project.

A Bronze Age Textile Database

An important aim of CinBA is to create an open access database of textile remains from Bronze Age Europe. Data are mainly taken from the larger catalogues of Bronze Age textiles. At the moment, the database contains textiles from 18 countries and has over 700 entries. Work is still in progress and more finds will be added. We are keen to get the database as complete as possible, and ask anybody who knows of Bronze Age textiles that are new, or for other reasons not catalogued to send information for the database to Sophie Bergerbrant. When the project is finished, the database will be accessible via the Internet.

Contact:

Lise Bender Jørgensen: lise.bender@hf.ntnu.no
Sophie Bergerbrant: sophie.bergerbrant@ntnu.no
Further Information: <http://cinba.net/>

Textile Calendar 2011

29 June 2011 – 30 January 2012: De Bronze & d'Or.
Vivre au quotidien à l'âge du Bronze en France
2200 a 700 av. J.-C. Musée d'archéologie nationale et
Domaine national de Saint-Germain-en-Laye, France.
http://www.musee-archeologienationale.fr/homes/home_id20641_u112.htm

8 September: Why Leather?, UCL Institute of
Archaeology, London UK
<http://www.archleathgrp.org.uk/>

14-18 September: 17th EAA Annual Meeting, Oslo,
Norway
<http://www.e-a-a.org/2011.htm>

3-6 October: CIETA, Copenhagen, Denmark

8-9 October: Textiles from the Nile Valley, Antwerp,
Belgium
<http://www.dressid.eu/calendar/conference-textiles-nile-valley-antwerp>

General Information

Guidelines to Authors

The ATN aims to provide a source of information relating to all aspects of archaeological textiles. Archaeological textiles from both prehistoric and historic periods and from all parts of the world are covered in the ATN's range of interests.

1. Contributions can be in English, German or French.

2. Contribution may include accounts of work in progress. This general category includes research/activities related to archaeological textiles from recent excavations or in museums/galleries. Projects may encompass technology and analysis, experimental archaeology, documentation, exhibition, conservation and storage. These contributions can be in the form of notes or longer feature articles.

3. Contributions may include announcements and reviews of exhibitions, seminars, conferences, special courses and lectures, information relating to current projects and any queries concerning the study of archaeological textiles. Bibliographical information on new books and articles is particularly welcome.

4. References should be in the Harvard System (e.g. Smith 2007, 56), with bibliography at the end (see previous issues). No footnotes or endnotes.

5. All submissions are to be made in electronic text file format (preferably Microsoft Word) and are to be sent electronically or by mail (a CD-ROM).

6. Illustrations should be electronic (digital images or scanned copies at 600dpi resolution or higher). Preferred format is TIFF. Illustrations should be sent as separate files and not imbedded in text. Colour images are welcome.

7. All contributions are peer-reviewed by the members of scientific committee.

8. The Editors reserve the right to suggest alterations in the wording of manuscripts sent for publication.

Please submit contributions by post to:

Archaeological Textiles Newsletter
Centre for Textile Research
University of Copenhagen

Njalsgade 102
DK-2300 Copenhagen S
Denmark

Or by electronic mail to the corresponding editor:

Margarita Gleba: margarita@atnfriends.com

Or to editors:

Eva Andersson: eva@atnfriends.com

Ulla Mannering: ulla@atnfriends.com

Copyright

Copyright in text remains with the individual authors. Copyright in images remains with the originating source.

N.B. In the near future, ATN will be accessible in an electronic format. Therefore all copyrights have to be cleared for this medium.

Disclaimer

The views expressed by authors in articles printed in ATN are not necessarily those of the Editors and are the responsibility solely of the individual contributors.