

Figures



Fig. 1 Satellite photograph of the Piraeus and Phaleron Bay (© Google Earth Pro 2010).

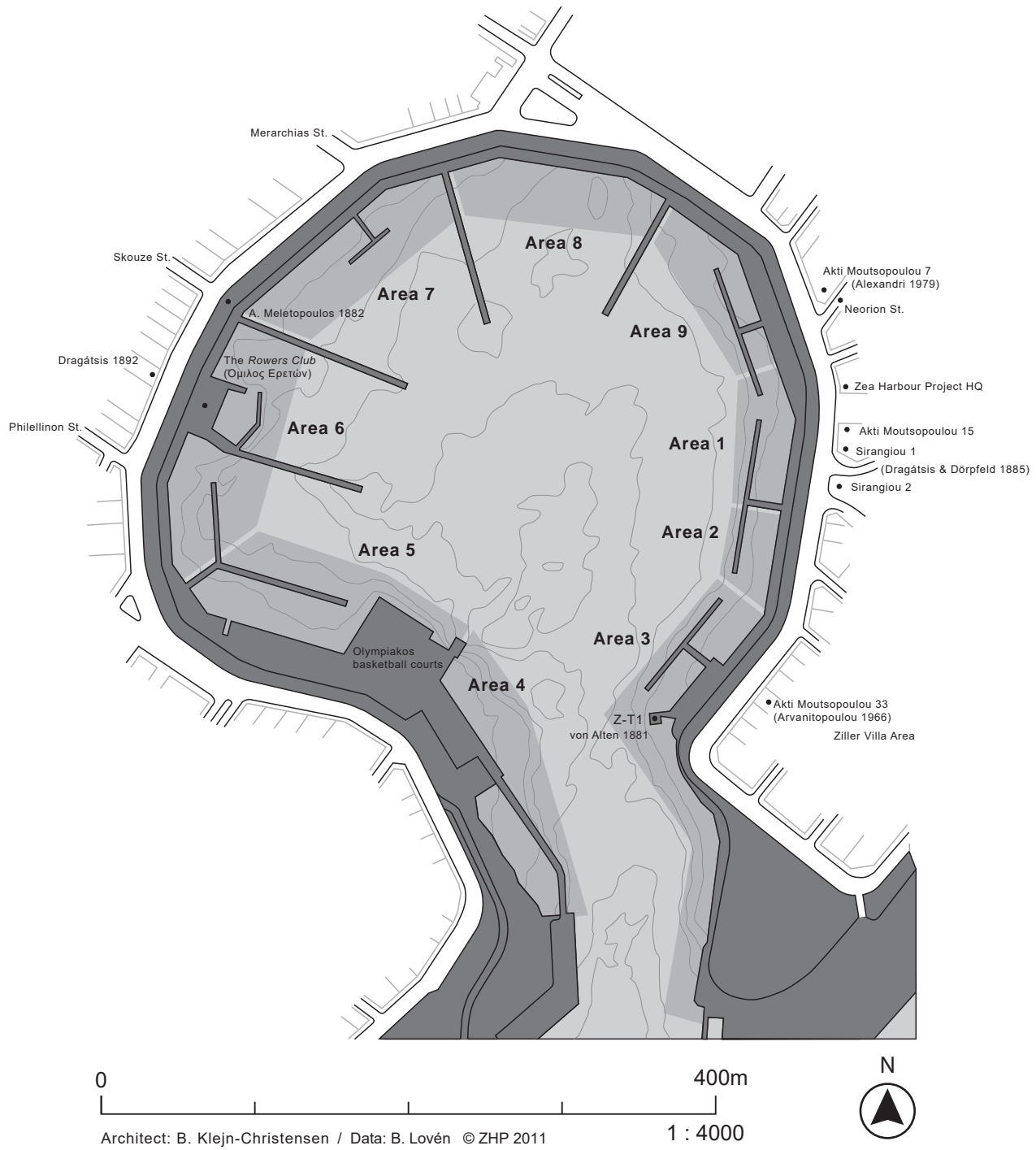

Fig. 2 Zea Harbour, designations of Areas 1–9.

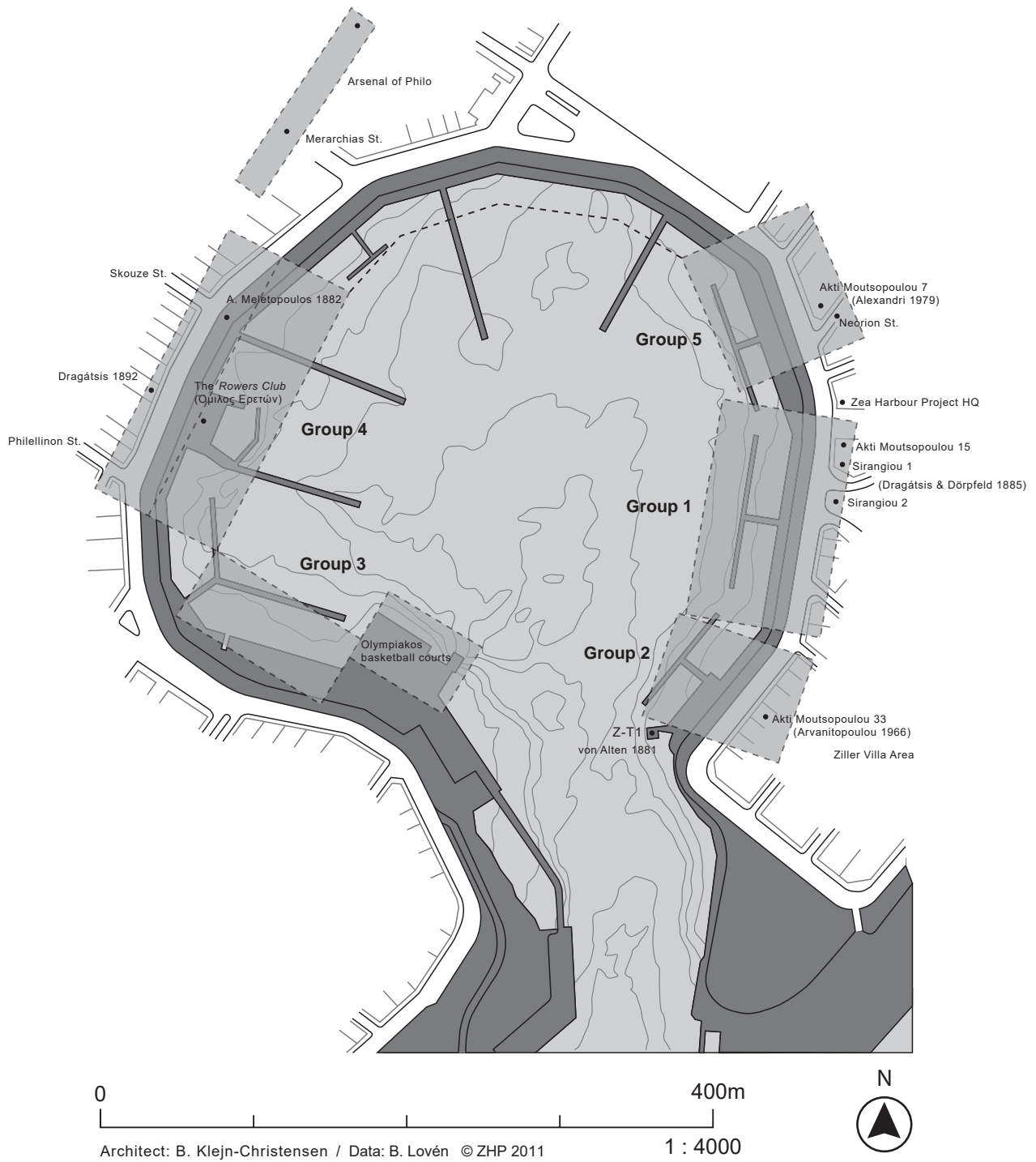

Fig. 3 Zea Harbour, topographical reconstruction of shipshed Groups 1–5.

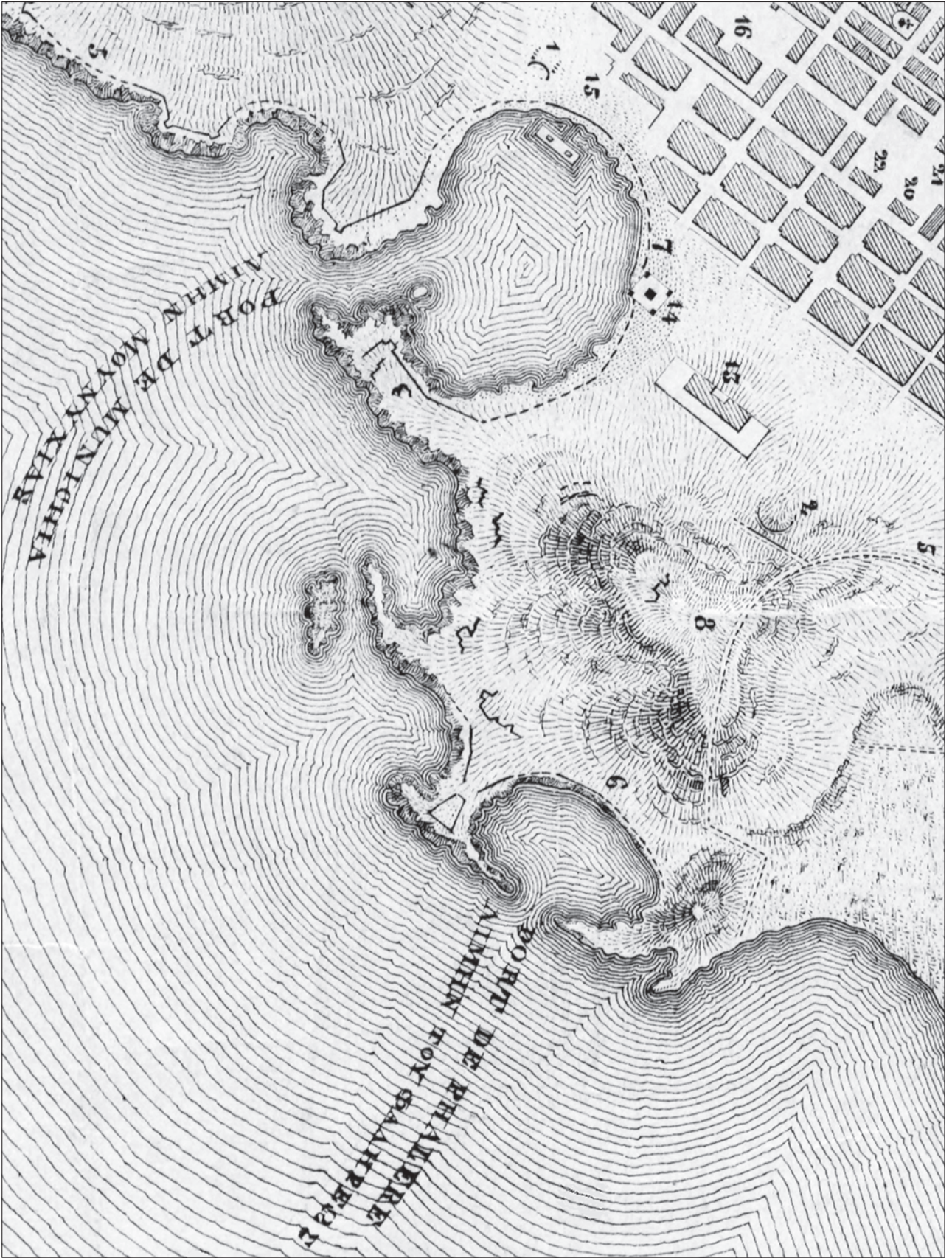

Fig. 4 Detail of Zea and Mounichia Harbours (Alphenoven 1837: *Plan topographique d'Alphen et de ses environs*, not to scale).

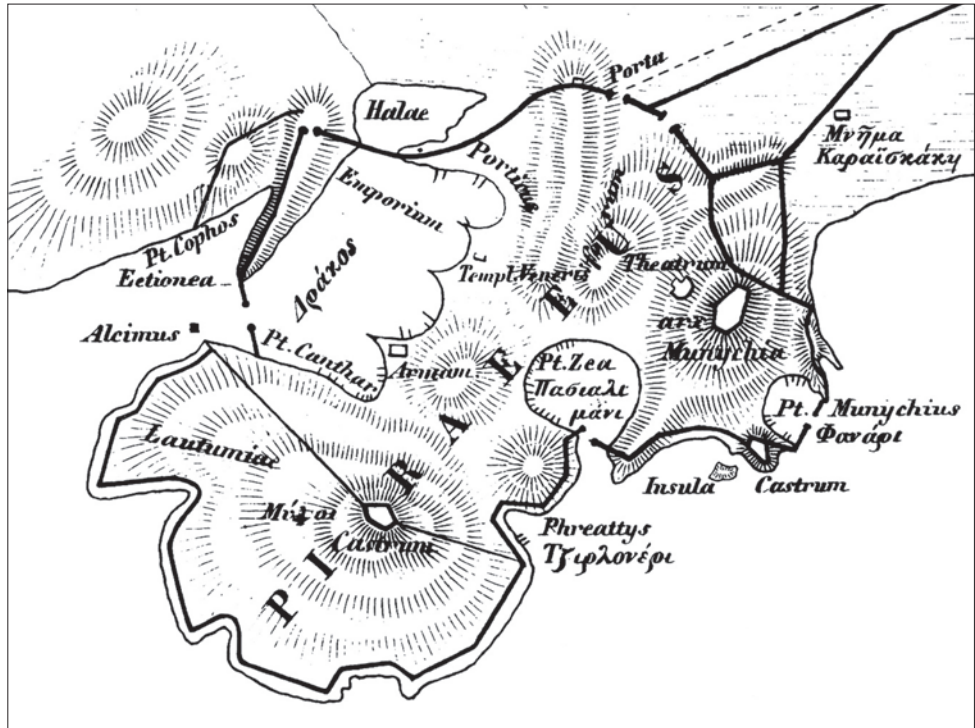

Fig. 5 Detail of the Piraeus (Ulrichs 1843: pl. I, *Athen mit seinen Häfen und Befestigungen*, not to scale).

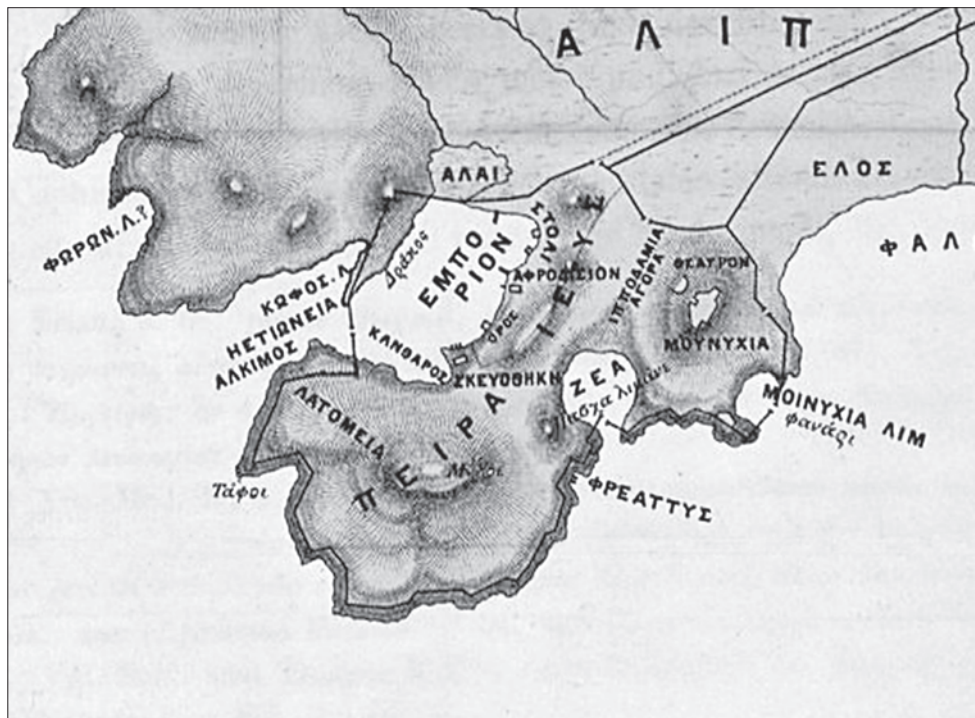

Fig. 6 Detail of the Piraeus (Ulrichs 1863: *Die Häfen und Langen Mauern von Athen*, not to scale).

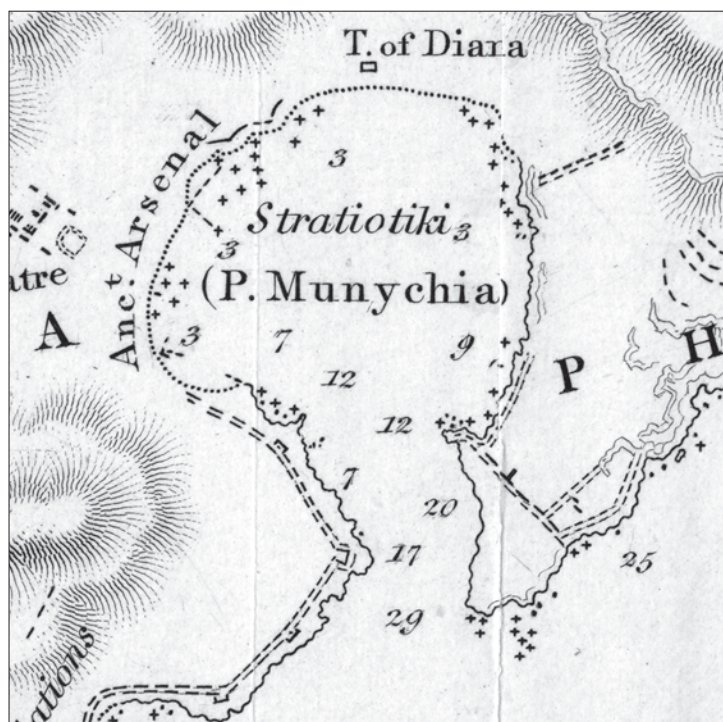

Fig. 7 Detail of Zea Harbour (Leake 1841: pl. 4, *Antiquities of Phalerum, Peiræus and Munychia*, re-scaled at about 1:8,000).



Fig. 8 Detail of Zea Harbour (Curtius 1841: Schaubert's map *Peninsula Piraica cum portubus subjectis*, re-scaled at ca 1:8,000).

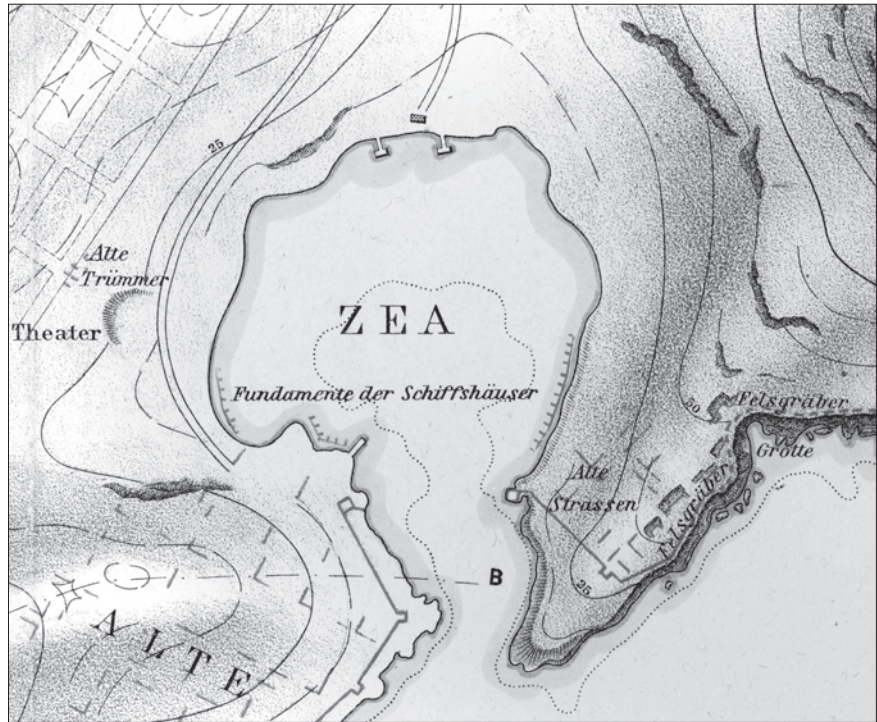

Fig. 9 Detail of Zea Harbour (Curtius 1868: pl. II, von Strantz's map *Plan vom Peiraiens* 1862, re-scaled at ca 1:8,000).



Fig. 10 Detail of Zea Harbour (Curtius & Kaupert 1881: pl. II, von Alten's map *Die Halbinsel Peiraiens* 1876/77, re-scaled at ca 1:8,000).



Fig. 11 Detail of Zea Harbour (Judeich 1931: pl. III, *Peiraias*, re-scaled at *ca* 1:8,000).

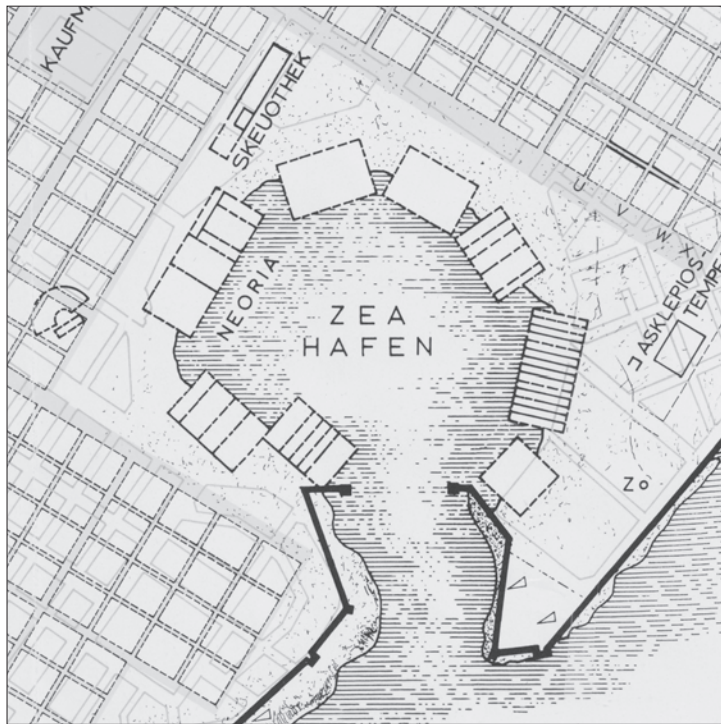

Fig. 12 Detail of Zea Harbour (Hoepfner & Schwandner 1994: fig. 14, re-scaled at *ca* 1:8,000).

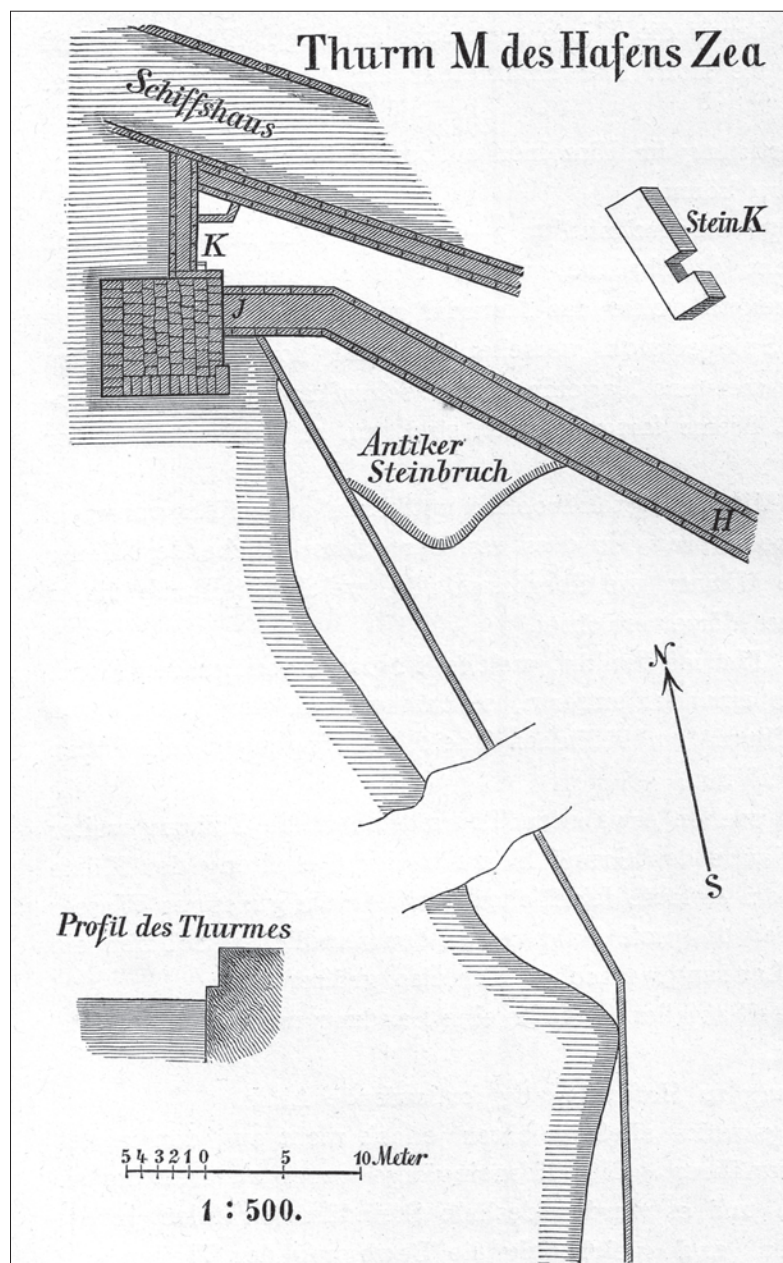

Fig. 13 Zea, Group 2, Tower Z-T1 and remains of possible ship-sheds (von Alten 1881: fig. 3, *Thurm M des Hafens Zea*, 1:500).

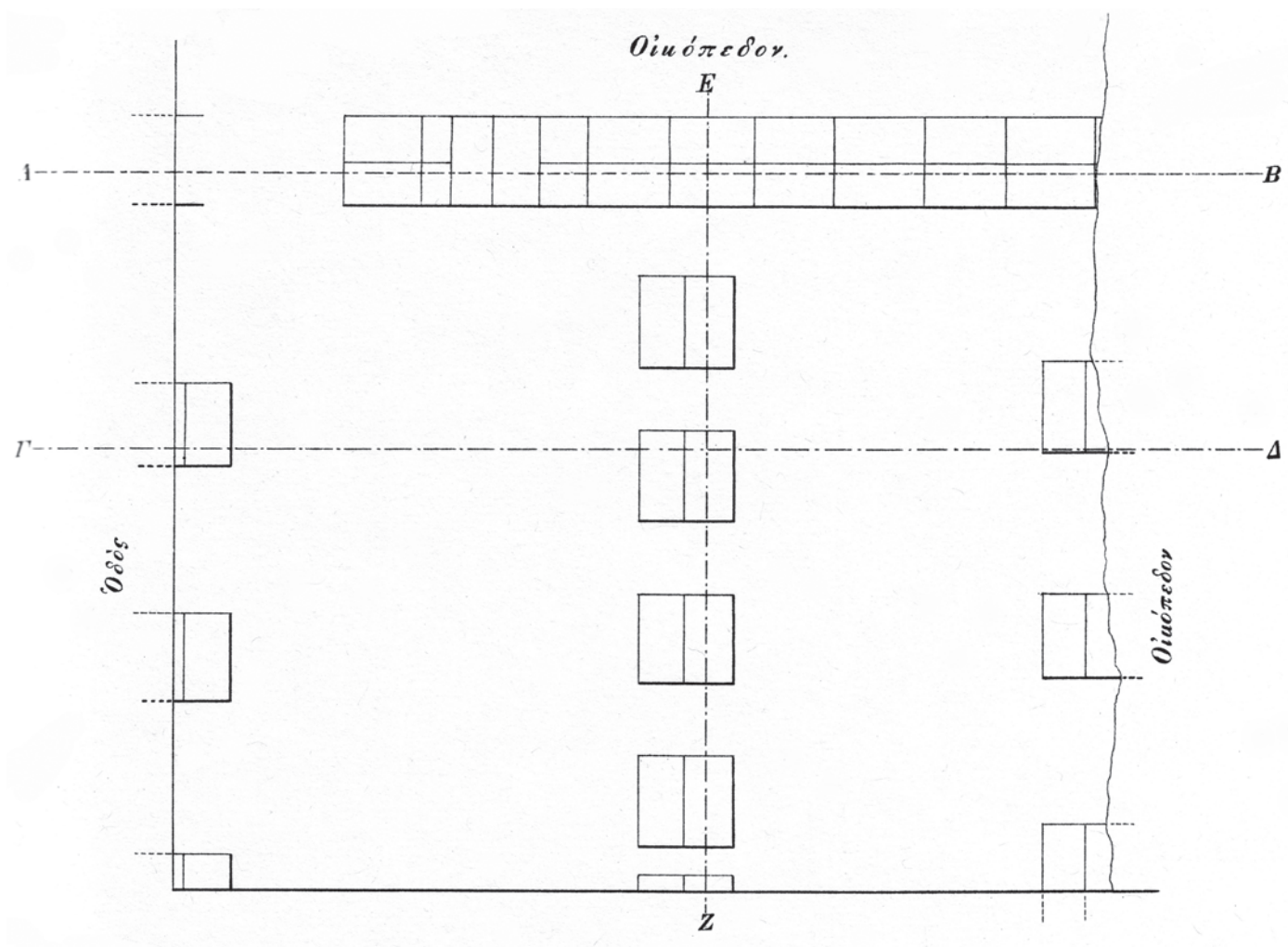

Fig. 14 Zea, Group 4, plan of possible shipsheds (A. Meletopoulos 1882, 1:100).

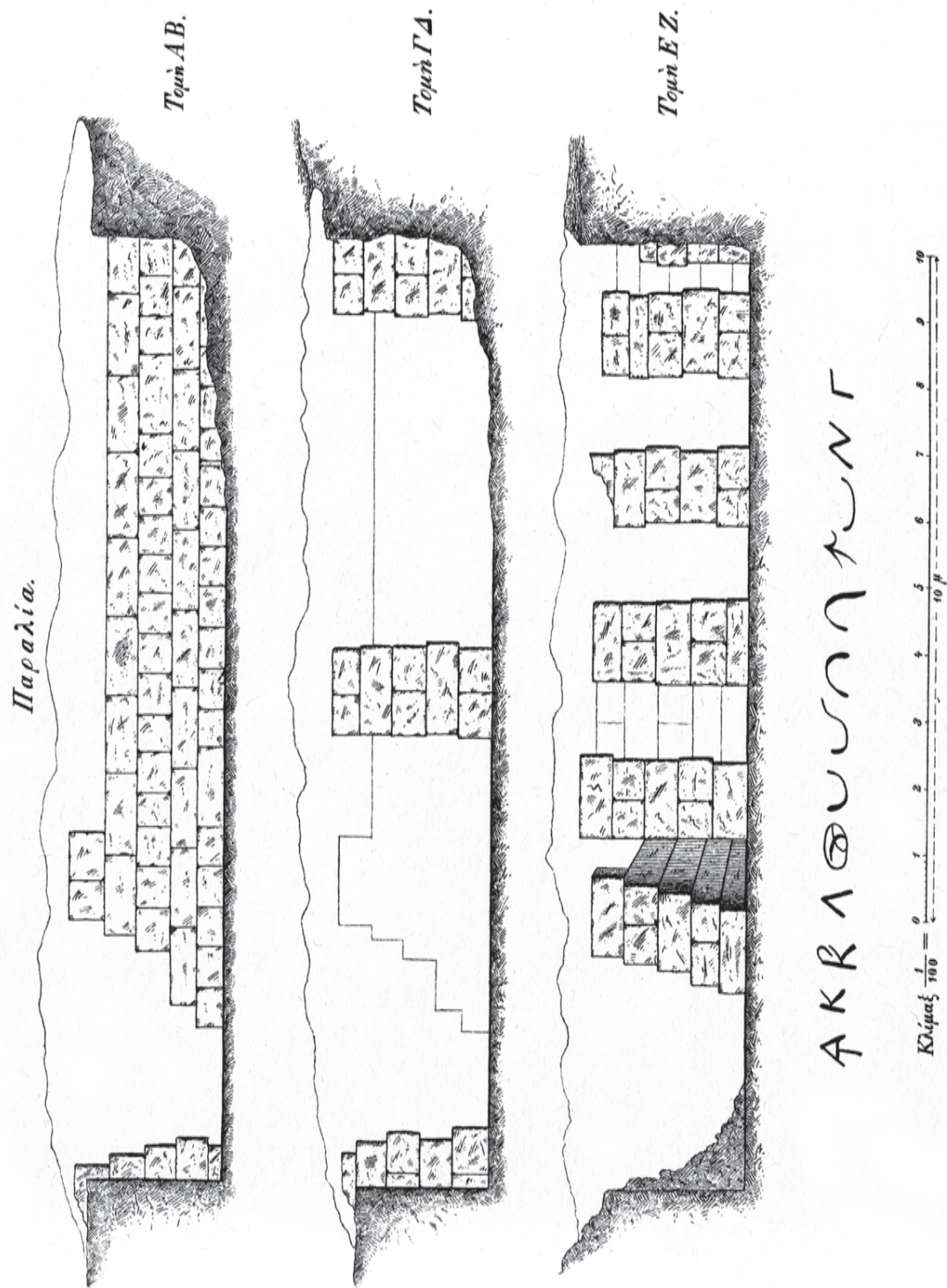

Fig. 15 Zea, Group 4, sections of possible shipsheds, including list of masons' marks (A. Meletopoulos 1882, 1:100).



Fig. 16 Map of the Piraeus (A. Meletopoulos 1882, not to scale).

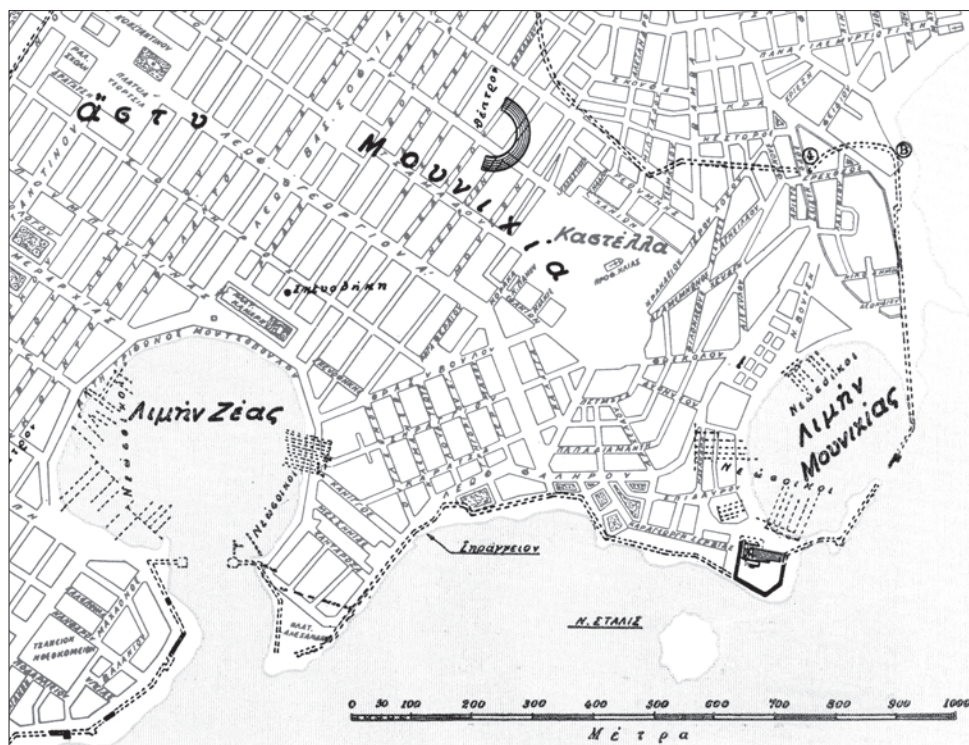

Fig. 17 Detail of Zea and Mounichia Harbours (I.A. Meletopoulos 1947, map Δ).

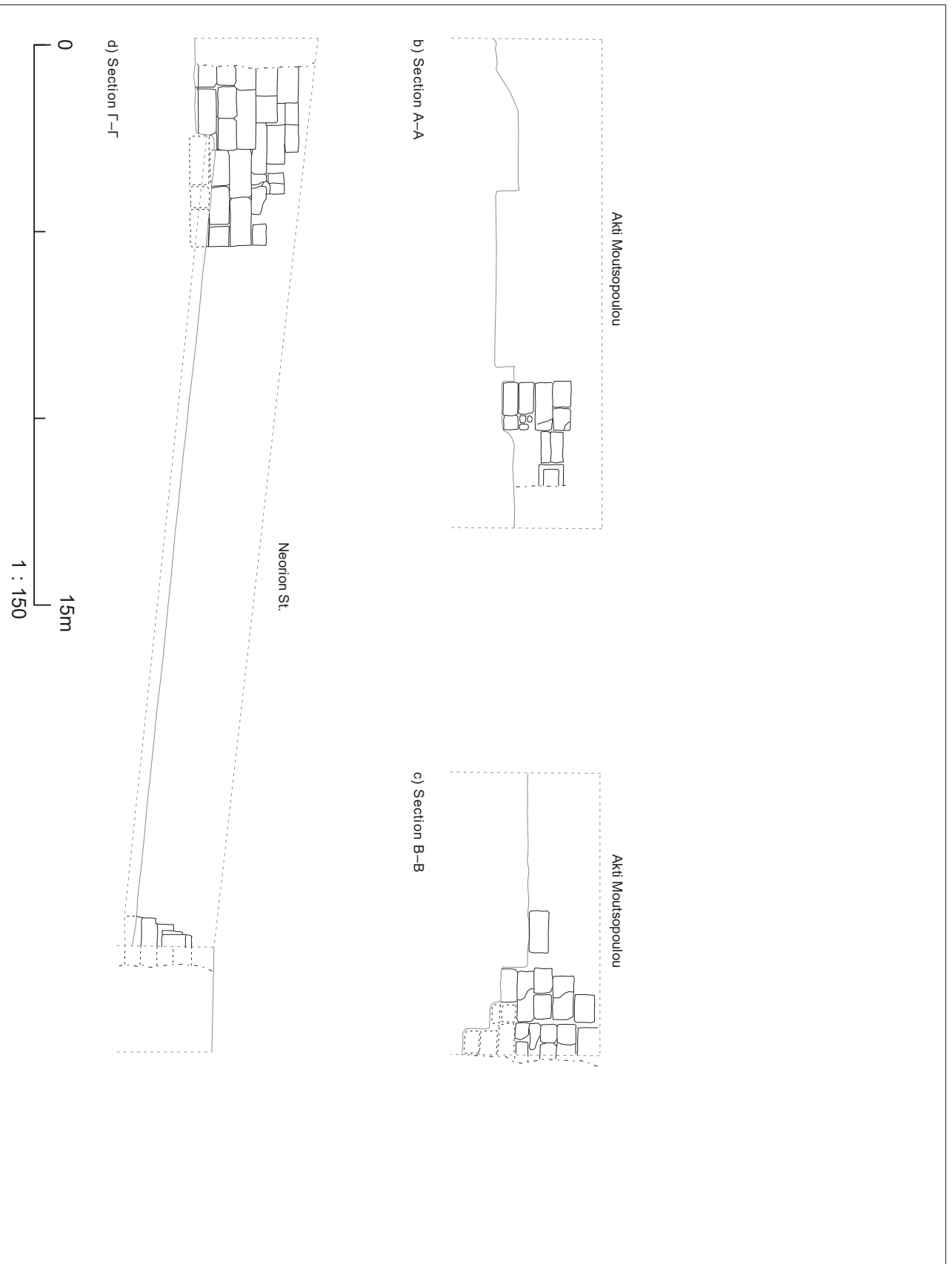

Fig. 19 Zea, Group 5, sections of shipsheds (traced by B. Klein-Christensen from Alexandri 1973: fig. 35, re-scaled at 1:150).

Fig. 20 Zea, Group 5, plan of shipsheds (traced by B. Klein-Christensen from Alexandri 1973: fig. 34, re-scaled at 1:150).

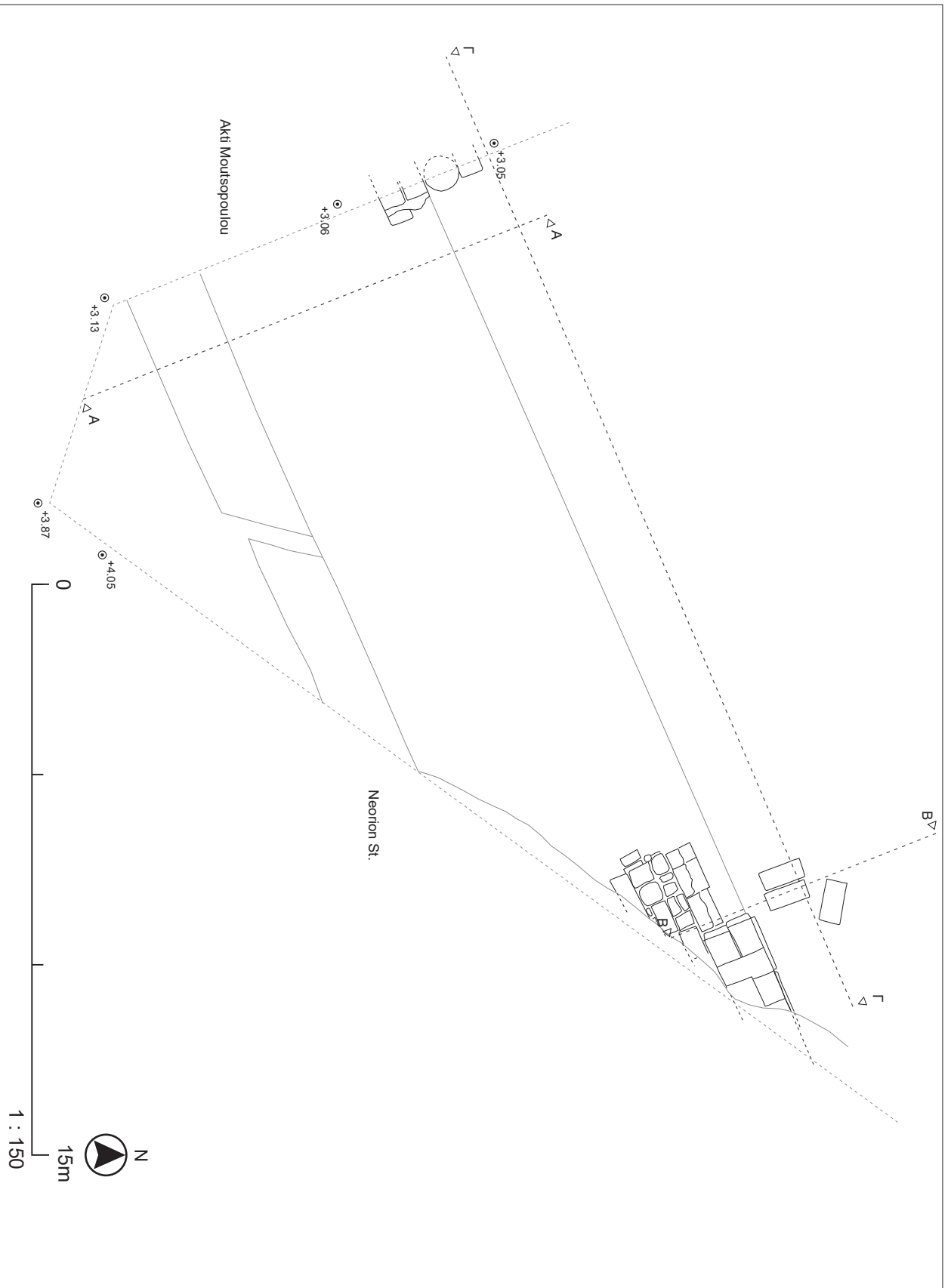



Fig. 21 Mounichia Harbour (modern Mikrolimano), topographical reconstruction of shipshed Groups 1-7.

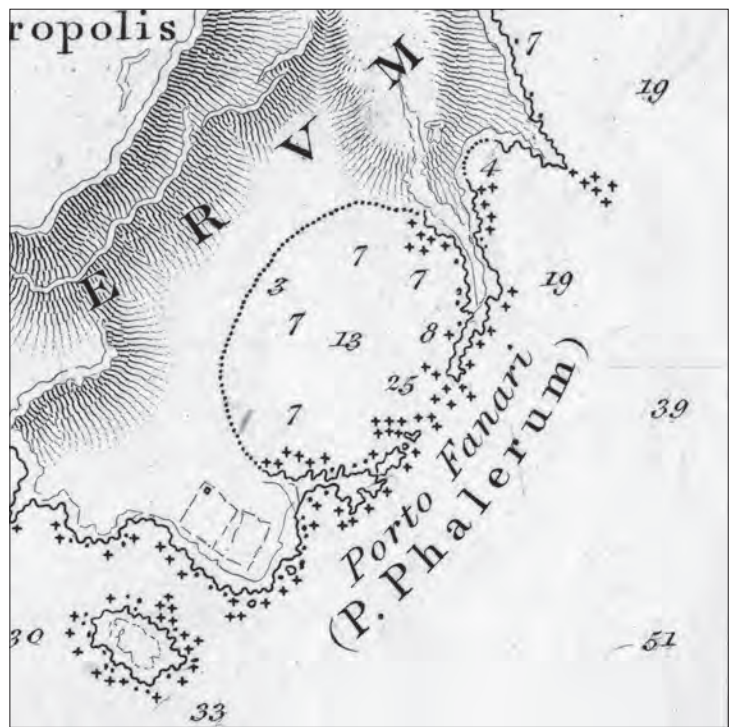

Fig. 22 Detail of Mounichia Harbour (Leake 1841: pl. 4, *Antiquities of Phalerum, Peiræus and Munychia*, re-scaled at about 1:8,000).

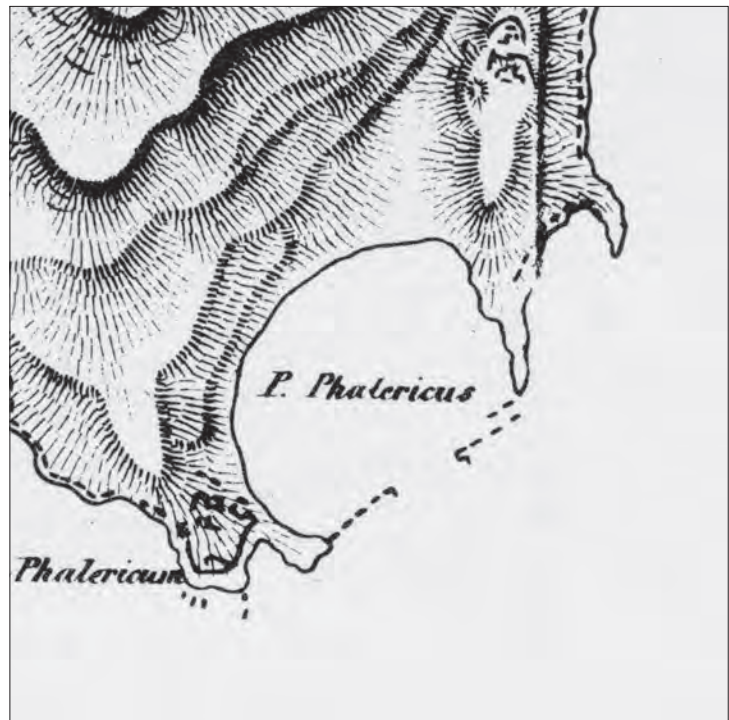

Fig. 23 Detail of Mounichia Harbour (Curtius 1841: Schaubert's map *Peninsula Piraica cum portubus subjectis*, re-scaled at ca 1:8,000).

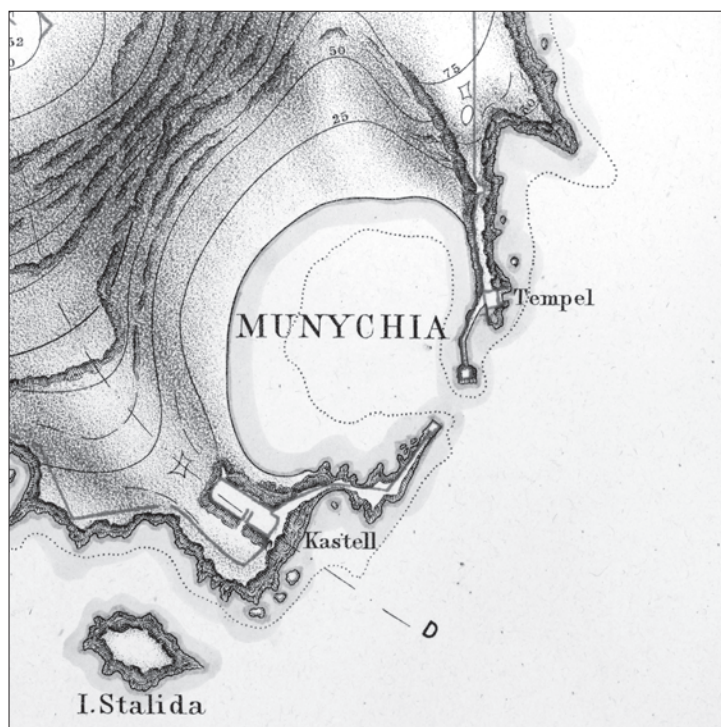

Fig. 24 Detail of Mounichia Harbour (Curtius 1868: pl. II, von Strantz's map *Plan vom Peiraiens* 1862, re-scaled at ca 1:8,000).

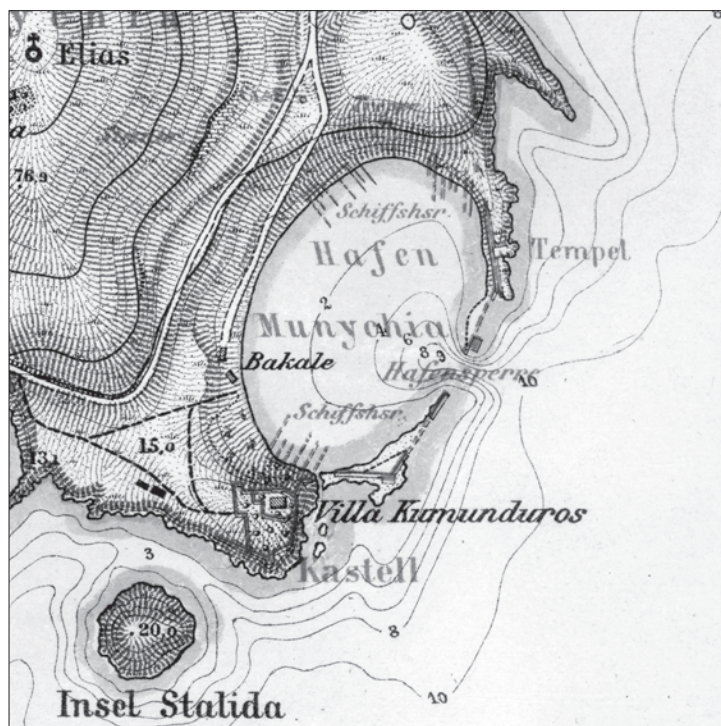

Fig. 25 Detail of Mounichia Harbour (Curtius & Kaupert 1881: pl. II, von Alten's map *Die Halbinsel Peiraiens* 1876/77, re-scaled at ca 1:8,000).



Fig. 26 Detail of Mounichia Harbour (Judeich 1931: pl. III, *Peirains*, re-scaled at ca 1:8,000).



Fig. 27 Detail of Mounichia Harbour (Hoepfner & Schwandner 1994: fig. 14, re-scaled at ca 1:8,000).

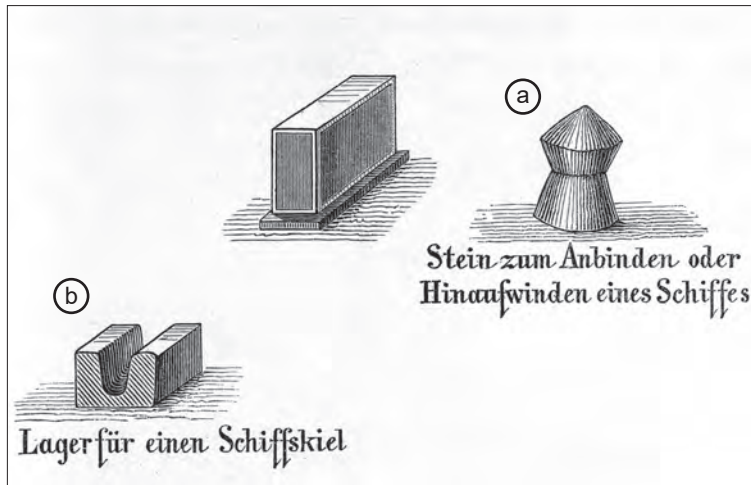

Fig. 28 Mounichia, architectural elements found in Group 2:
 a) bollard; b) probable architrave with gutter (von Alten 1881: fig. 9).

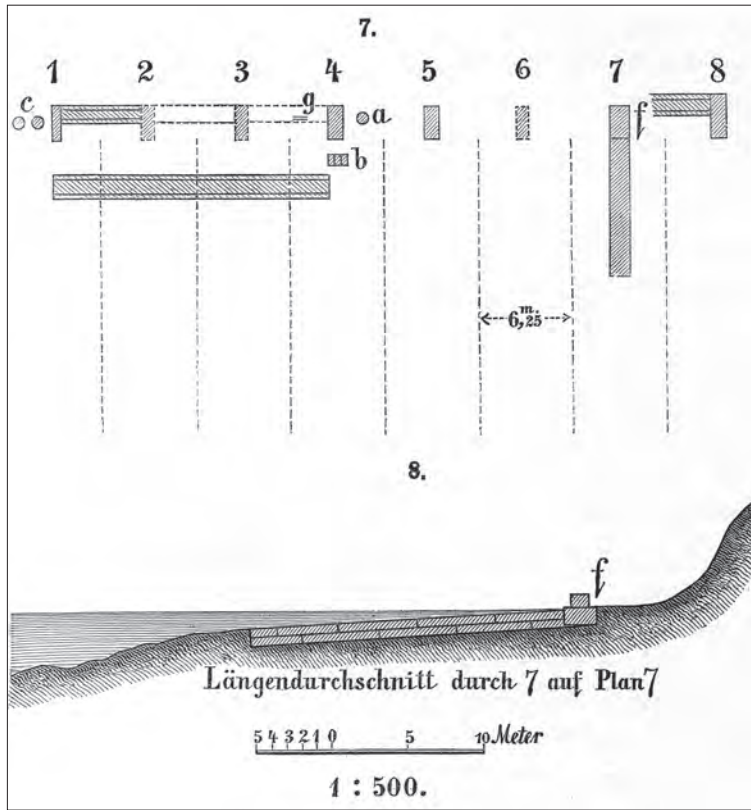

Fig. 29 Mounichia, Group 2, plan of structures 1–8,
 and section of structure 7 (von Alten 1881: figs. 7–8, 1:500).

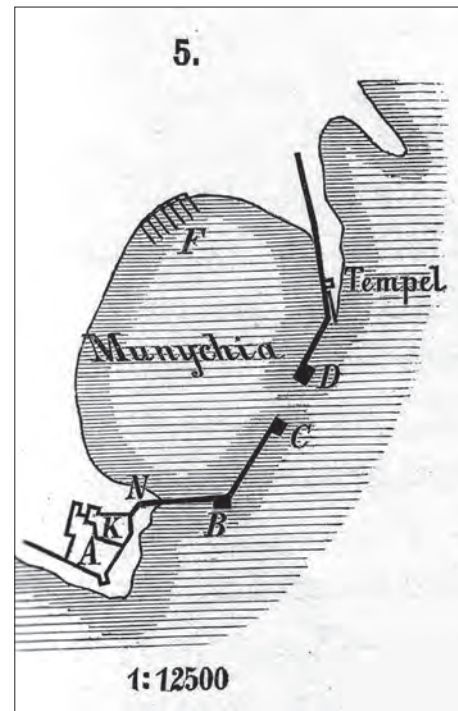

Fig. 30 Mounichia, Group 2, sketch map of
 possible shipsheds (von Alten 1881: fig. 5,
 about 1:12,500).

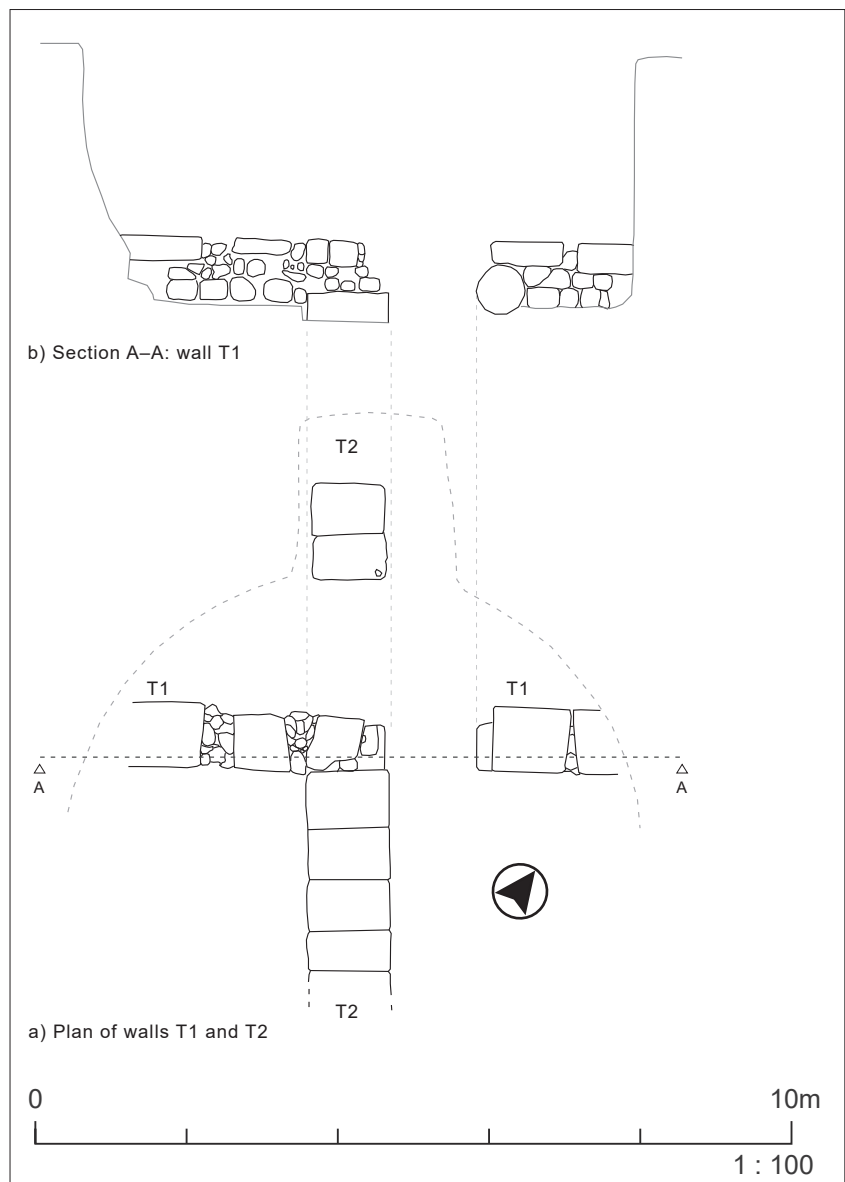

Fig. 31 Mounichia, Group 2, plan and section of possible shipsheds (traced by B. Klejn-Christensen from Liangouras 1967: fig. 9).

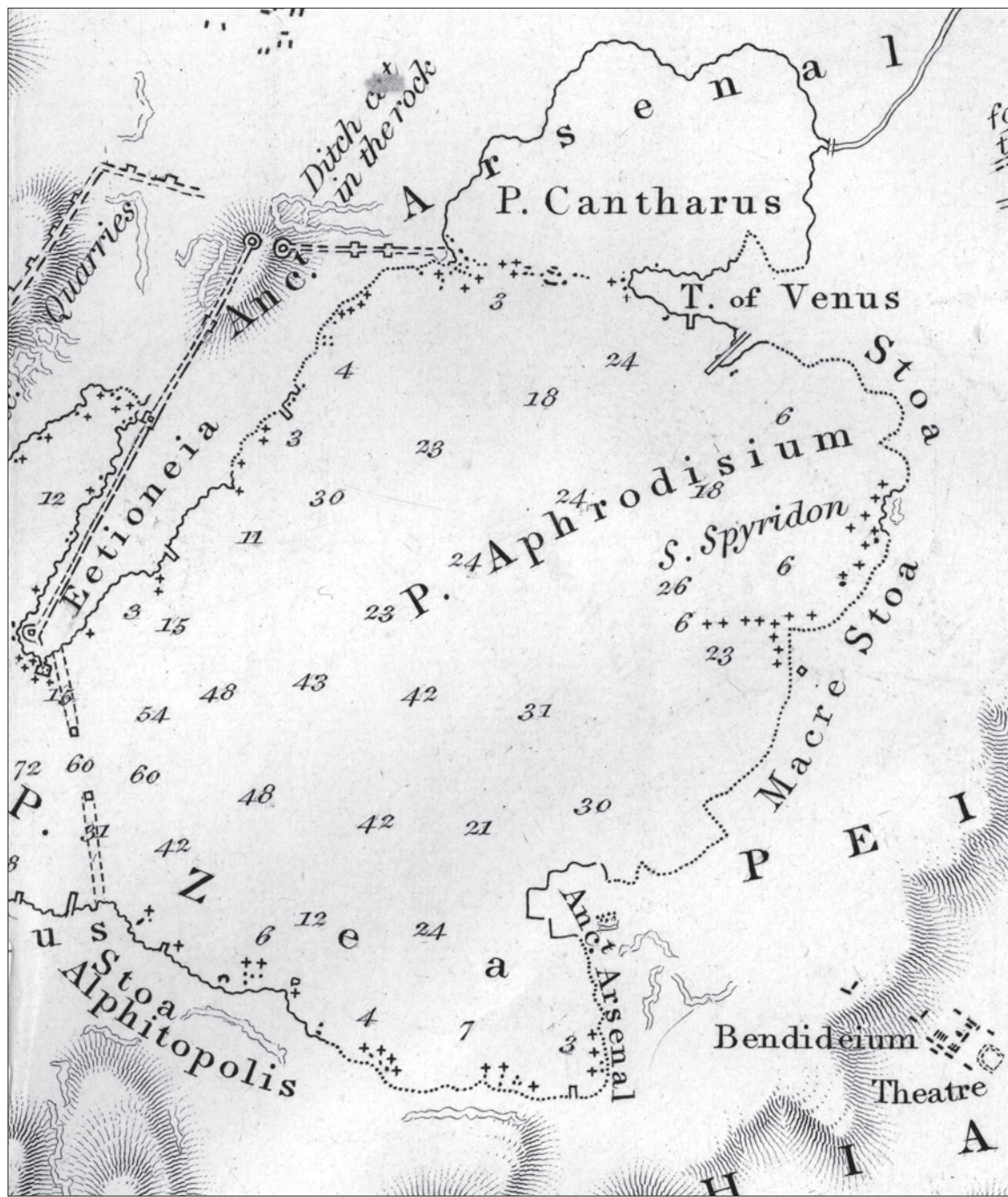

Fig. 32 Detail of Kantharos Harbour (Leake 1841: pl. 4, *Antiquities of Phalerum, Peiræus and Munychia*, re-scaled at about 1:8,000).

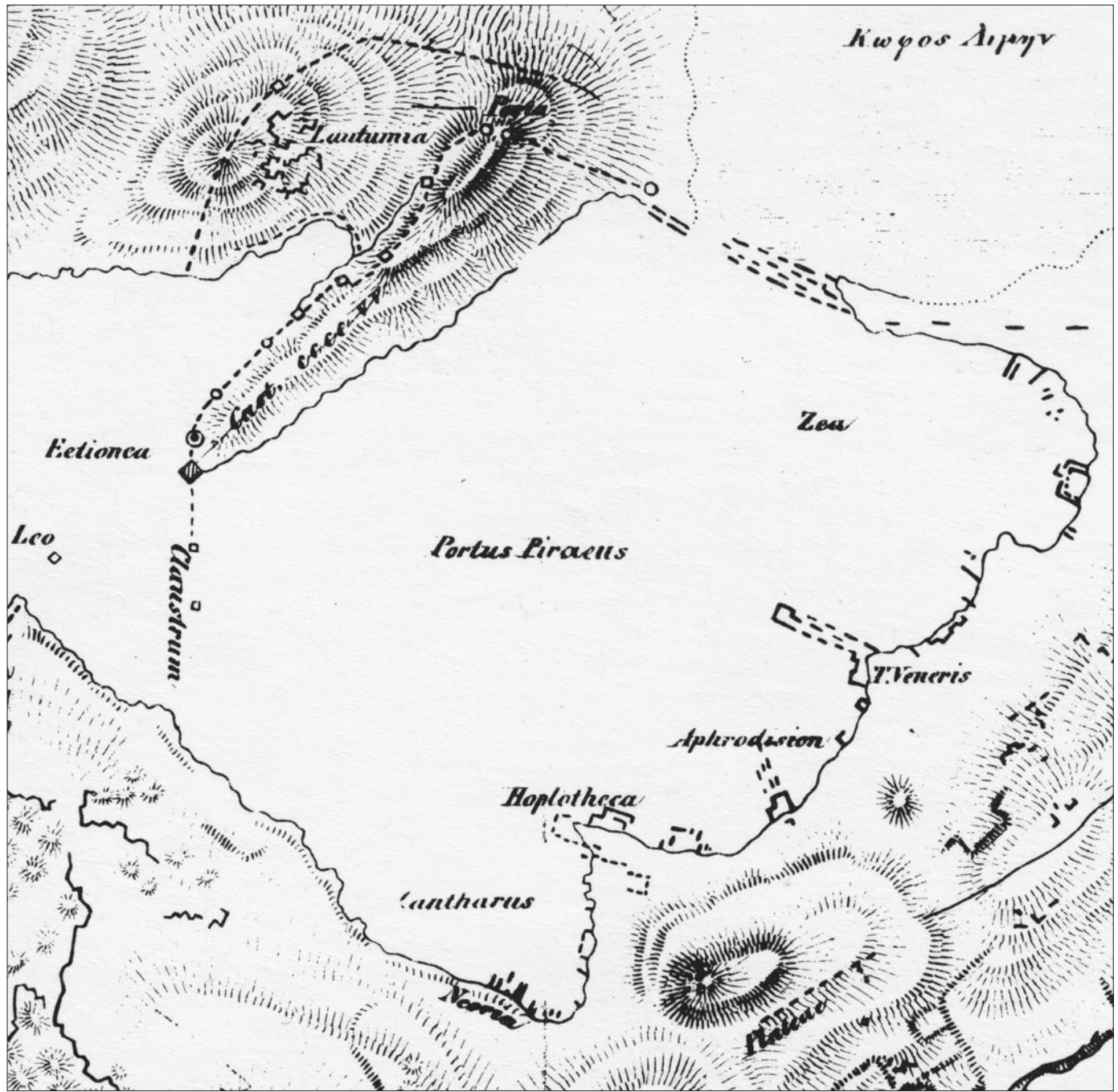

Fig. 33 Detail of the Kantharos Harbour (Curtius 1841: Schaubert's map *Peninsula Piraica cum portubus subjectis*, re-scaled at ca 1:8,000).



Fig. 34 Detail of Kantharos Harbour (Curtius & Kaupert 1881: pl. IIa, von Alten's map *Die Halbinsel Peiraius – nach Erbauung der Hippodamischen Stadtanlage und der Befestigungsmauern, 1876/77*, re-scaled at ca 1:8,000).

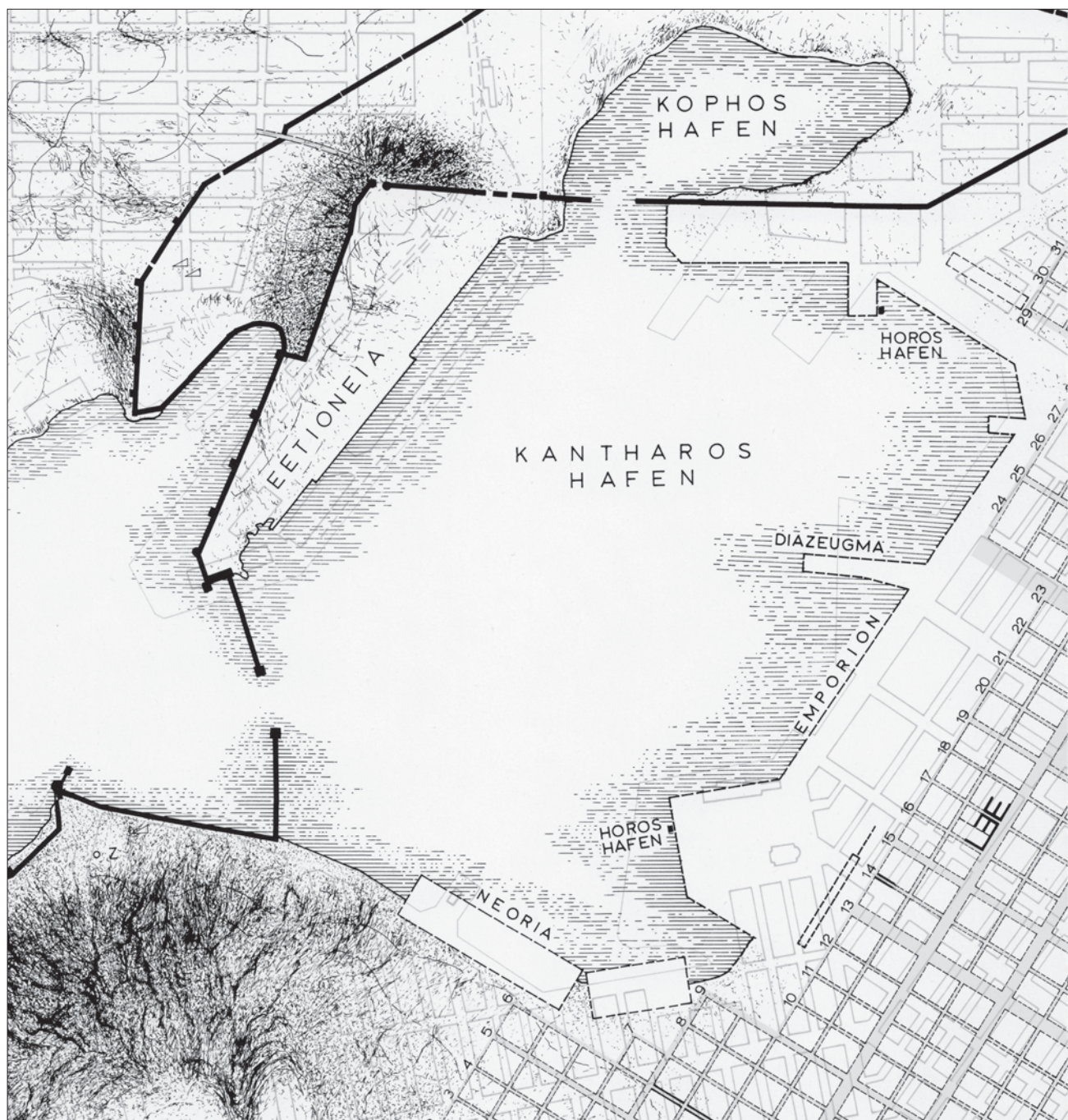

Fig. 35 Detail of Kantharos Harbour (Hoepfner & Schwandner 1994: fig. 14, re-scaled at ca 1:8,000).

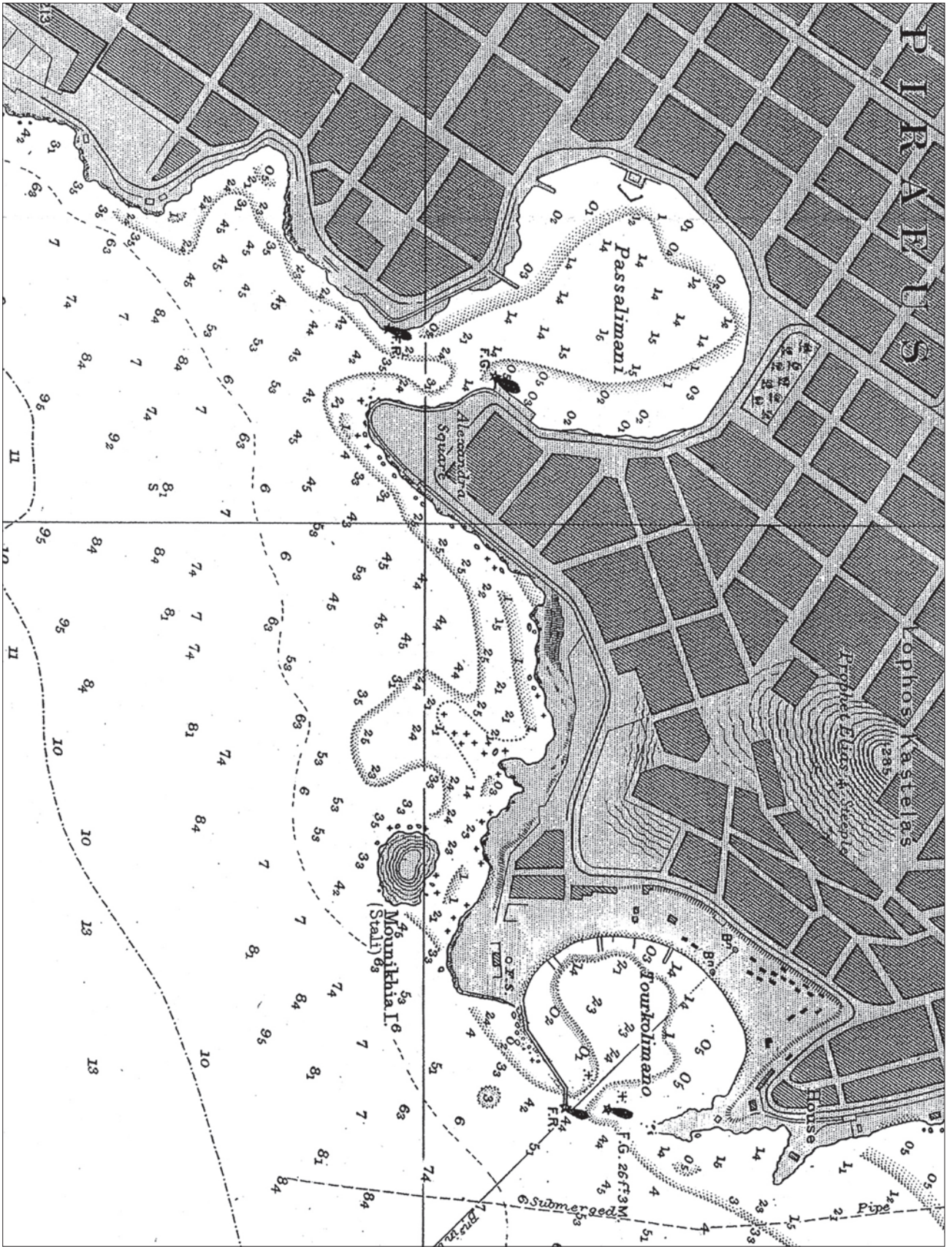

Fig. 36 British Admiralty Chart No. 1520 (1947), re-scaled at ca 1:8,000.

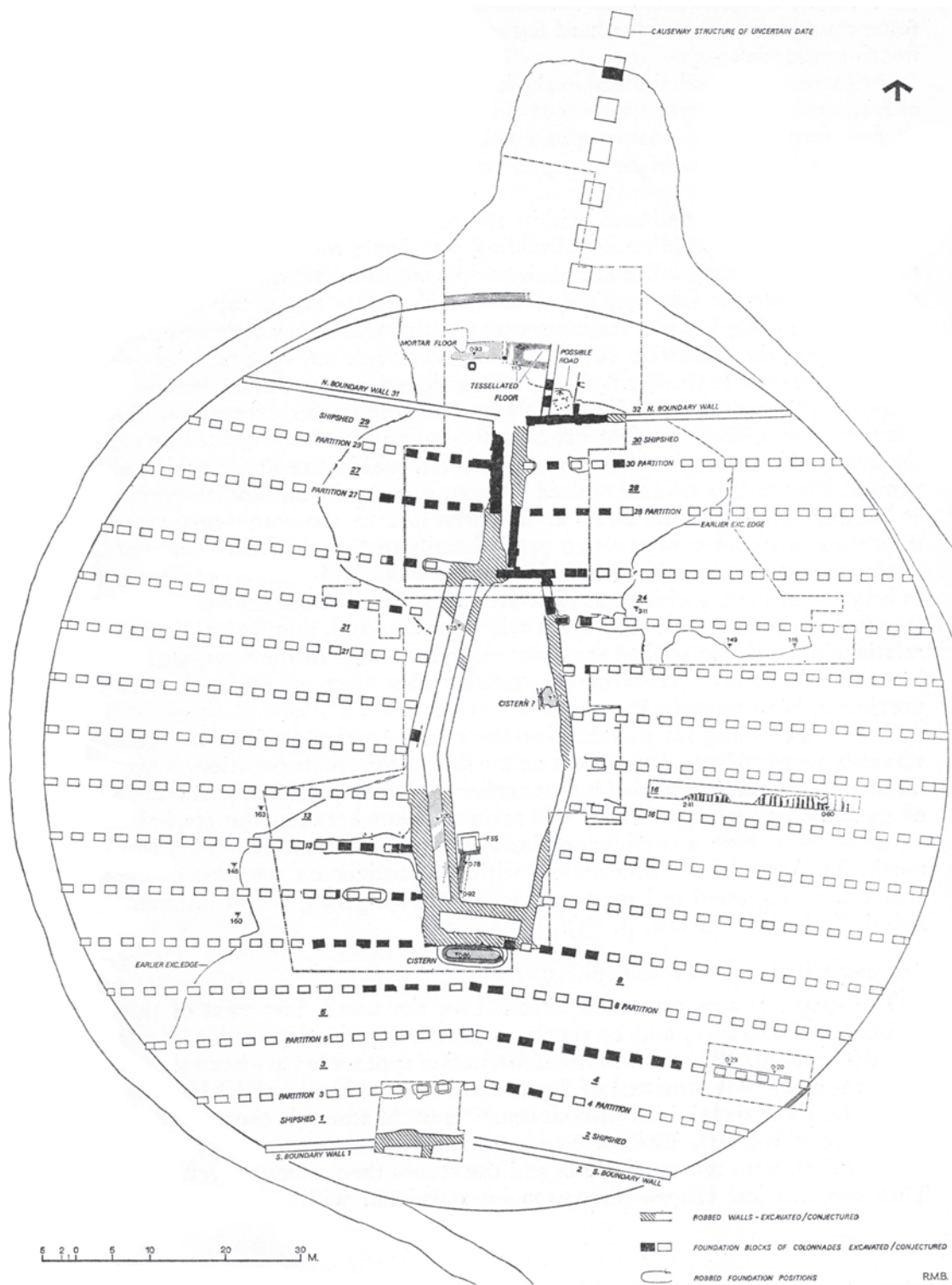

Fig 37 Carthage, Ilôt de l'Amirauté, Circular Harbour, plan of shipsheds 1–30 (Hurst 1979: fig. 1, scaled as in publication).

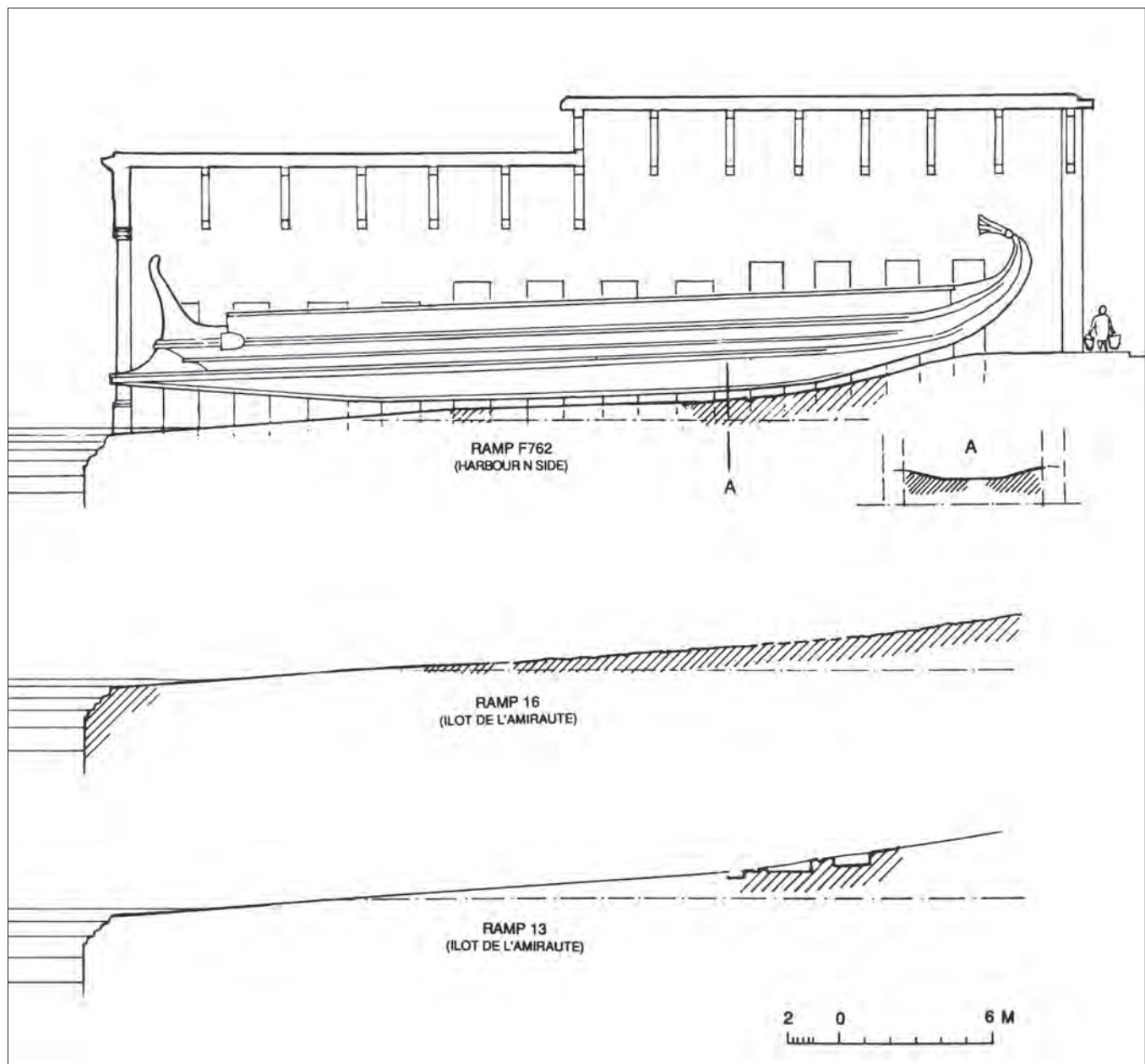

Fig. 38 Carthage, Circular Harbour, sections of ramps F762, 16 and 13 (Hurst 1994: fig. 3.2, 1:250).

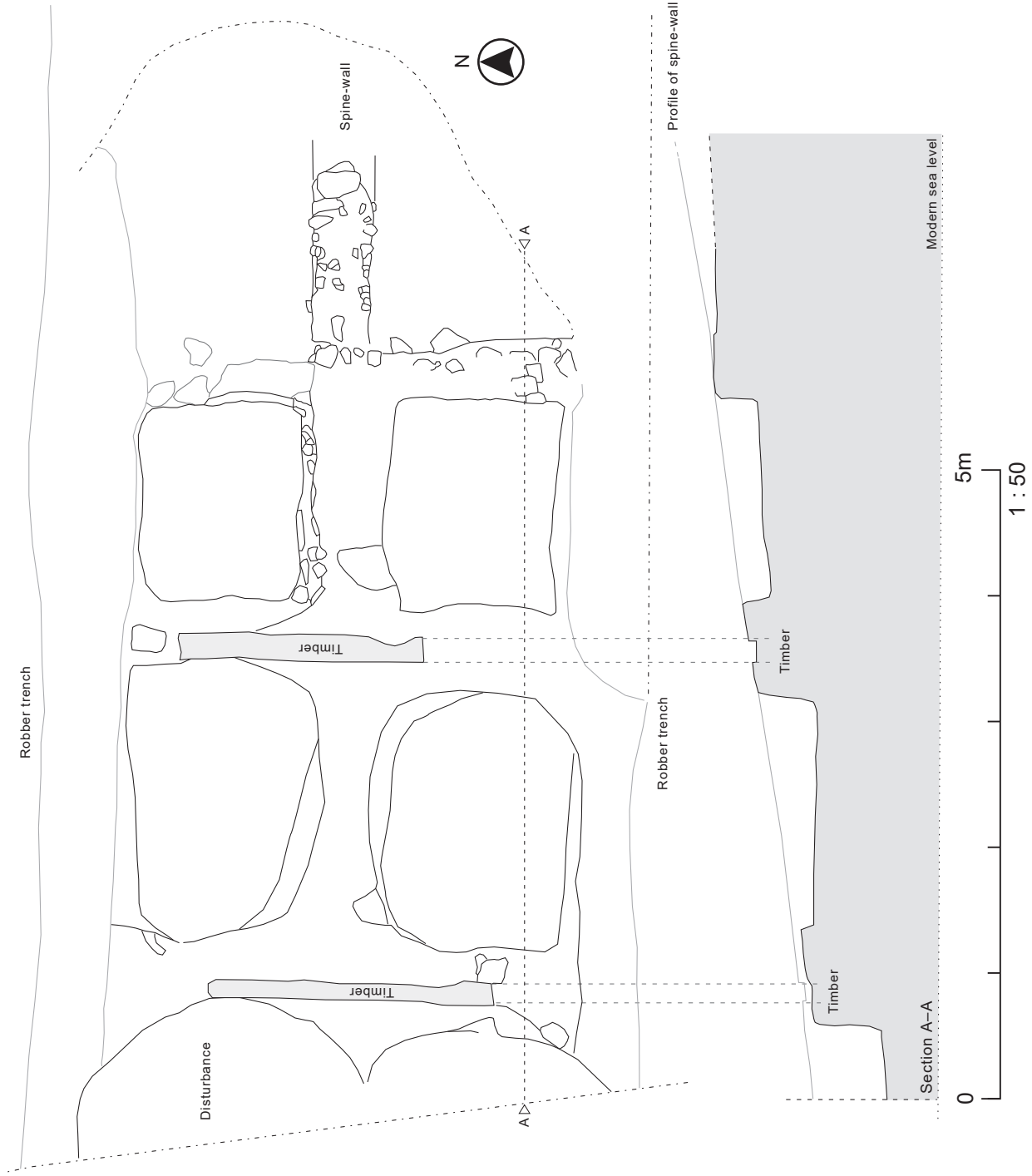

Fig. 39 Carthage, Îlot de l'Amirauté, Circular Harbour, plan and section of ramp 13 (traced by B. Klejn-Christensen from Hurst 1980: fig. 4, 1:50).

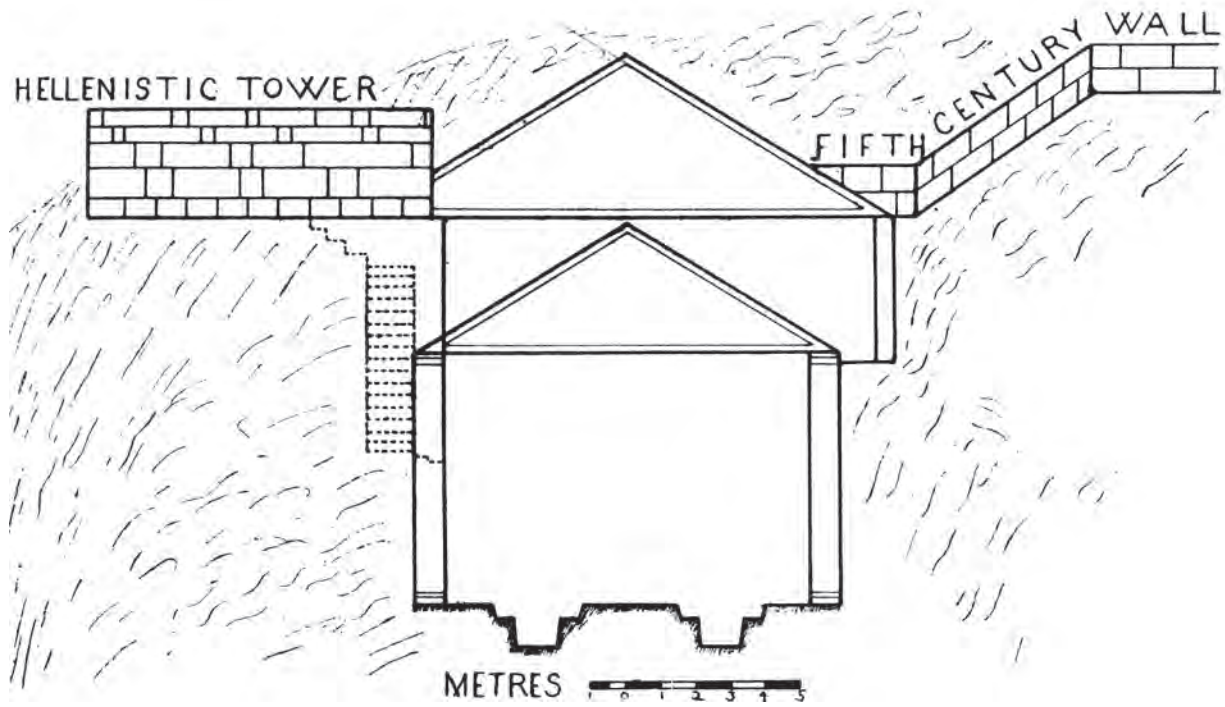

Fig. 42 Sounion, cross-section of shipsheds, including reconstruction of superstructure (Kenny 1947: pl. 34).

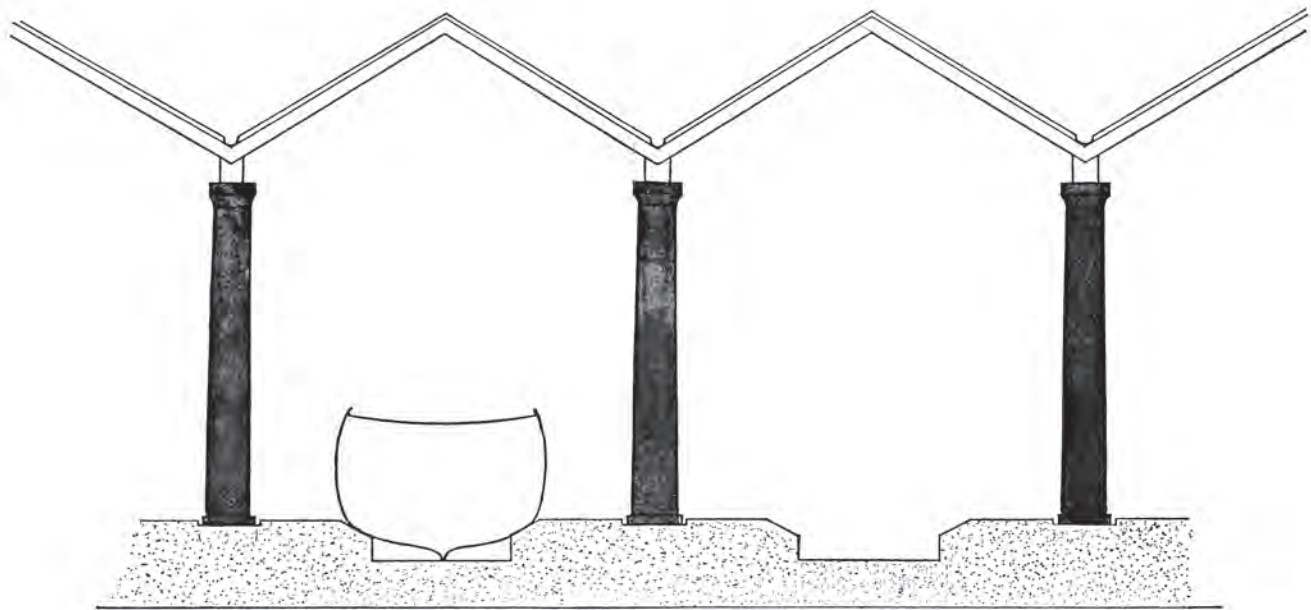

Fig. 43 Oiniadai, cross-section of shipsheds, including reconstruction of superstructure (Sears 1904: pl. XI, not to scale).

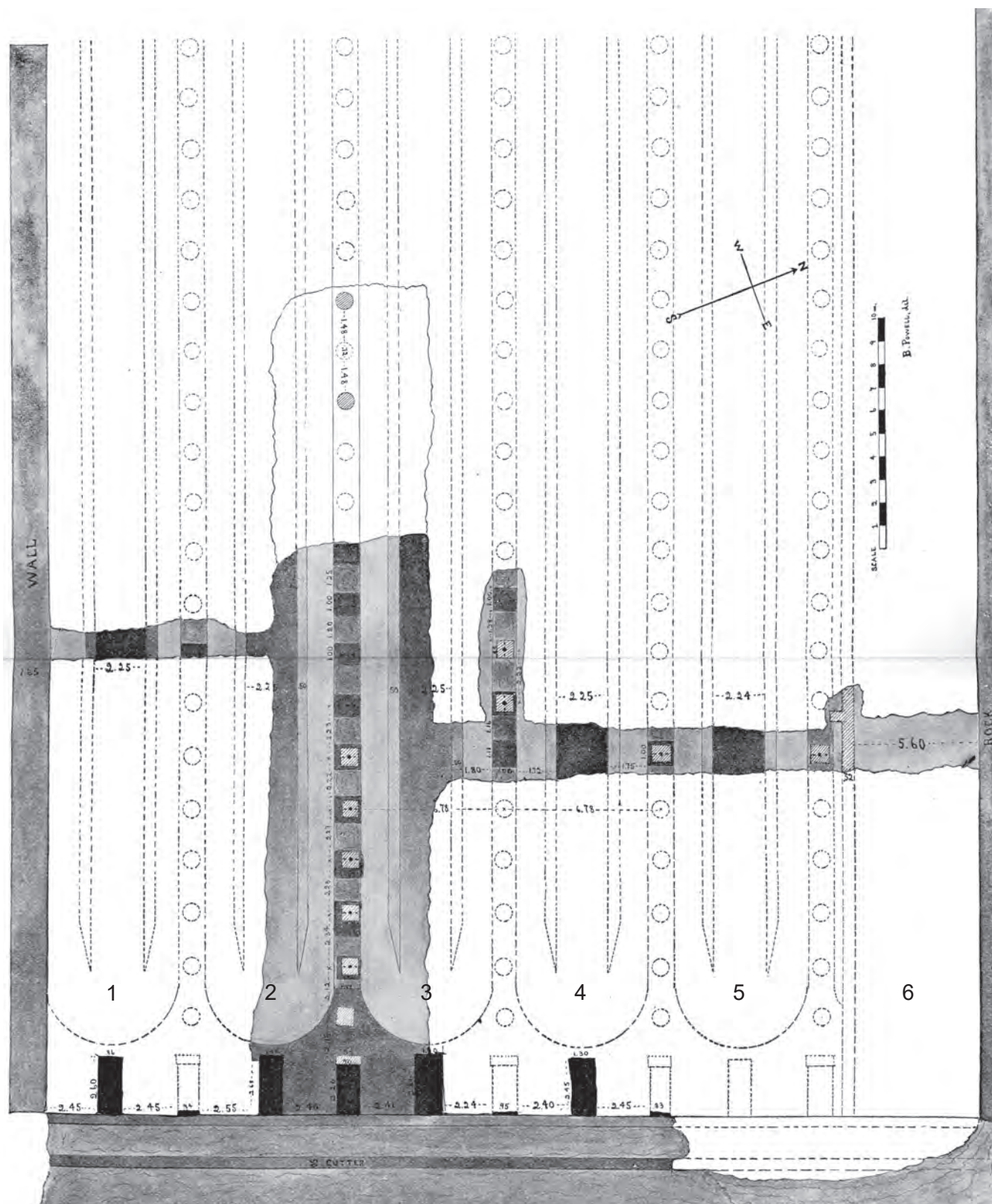

Fig. 44 Oiniadai, plan of shipsheds 1-6 (Sears 1904: pl. IX, scaled as in publication).

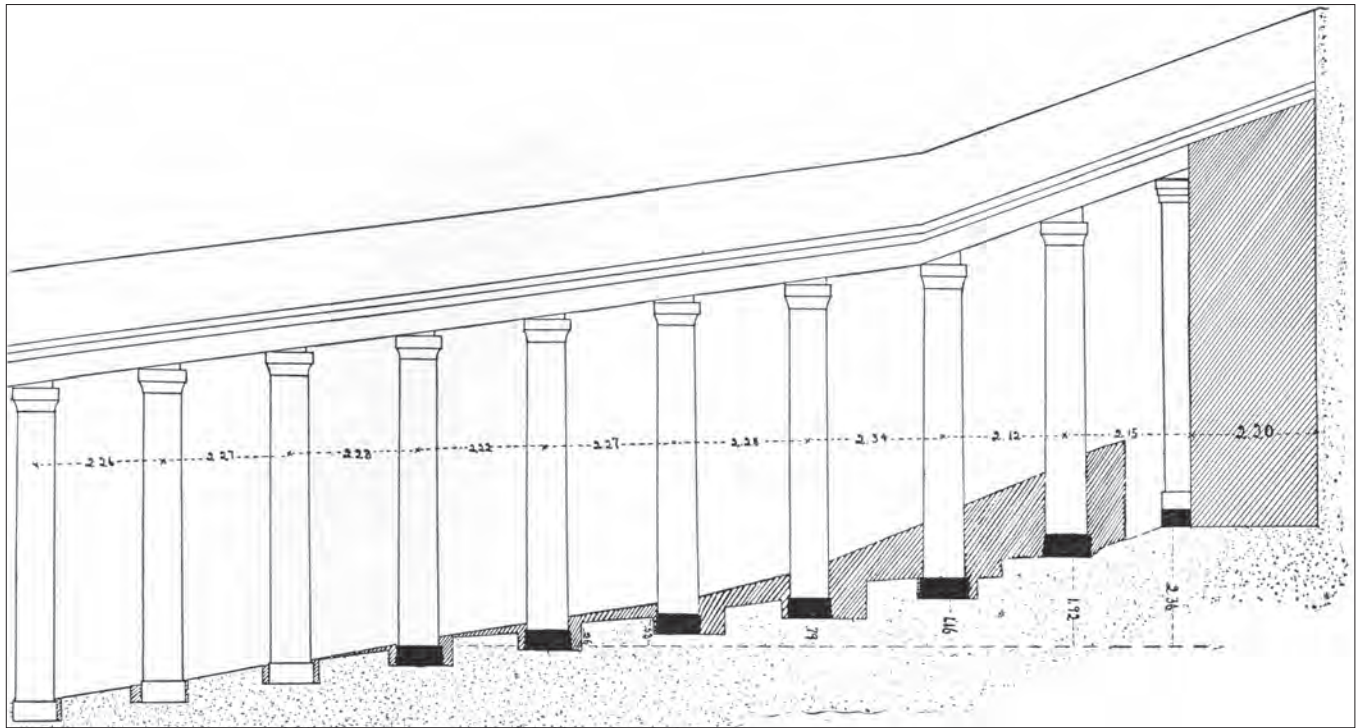

Fig. 45 Oiniadai, longitudinal-section of colonnade dividing shipsheds 2 and 3, including section of ramp and reconstruction of superstructure (Sears 1904: pl. X, scaled as in publication).

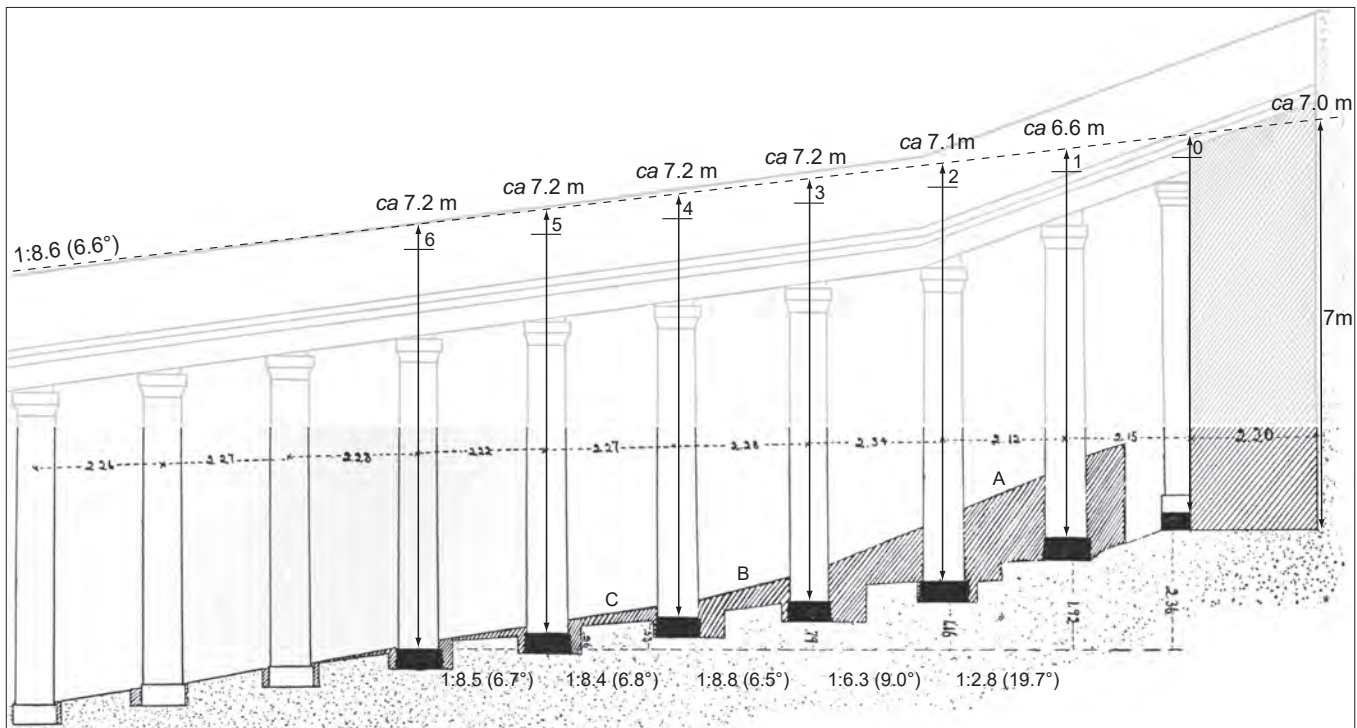

Fig. 46 Oiniadai, longitudinal-section of colonnade dividing shipsheds 2 and 3, including section of ramp and superstructure reconstruction by B. Lovén (Sears 1904: pl. X, scaled as in publication).

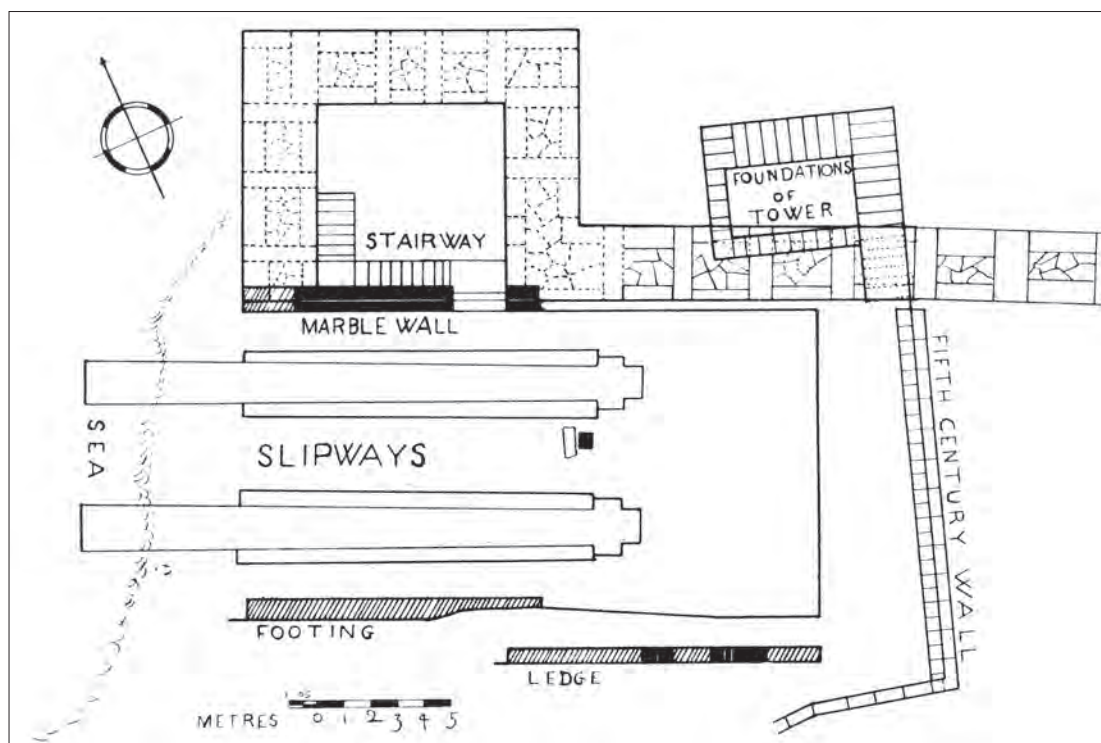

Fig. 47 Sounion, plan of shipsheds (Kenny 1947: pl. 31).

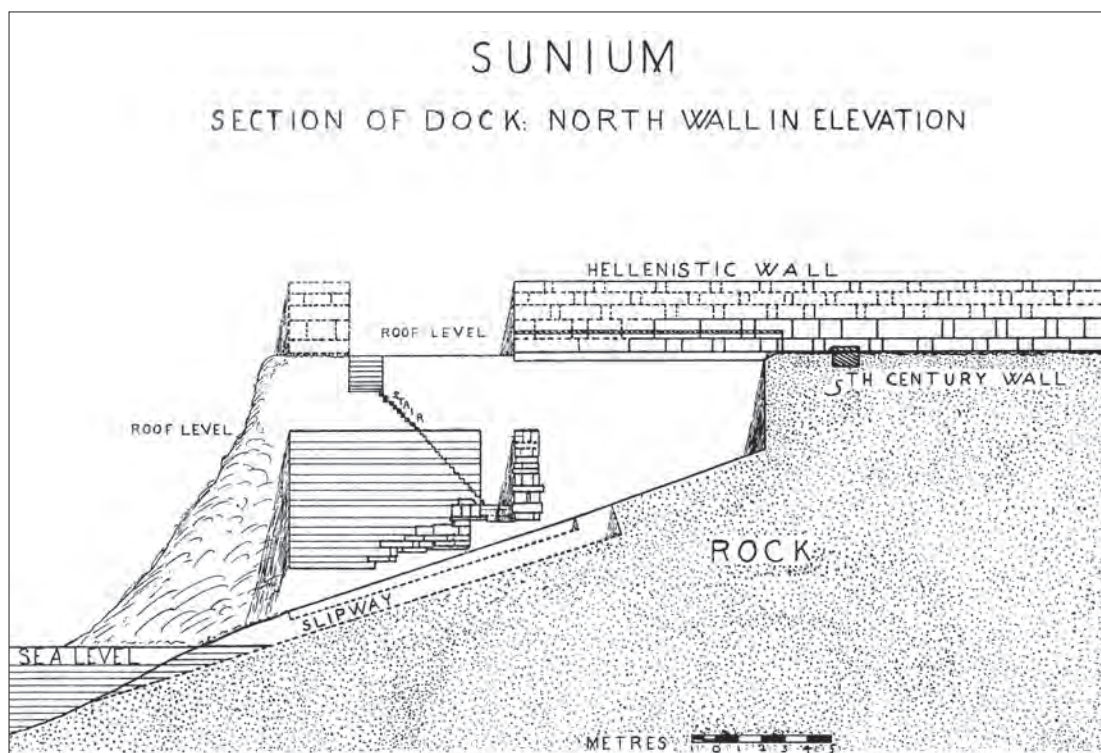

Fig. 48 Sounion, longitudinal-section of shipshed (Kenny 1947: pl. 32).

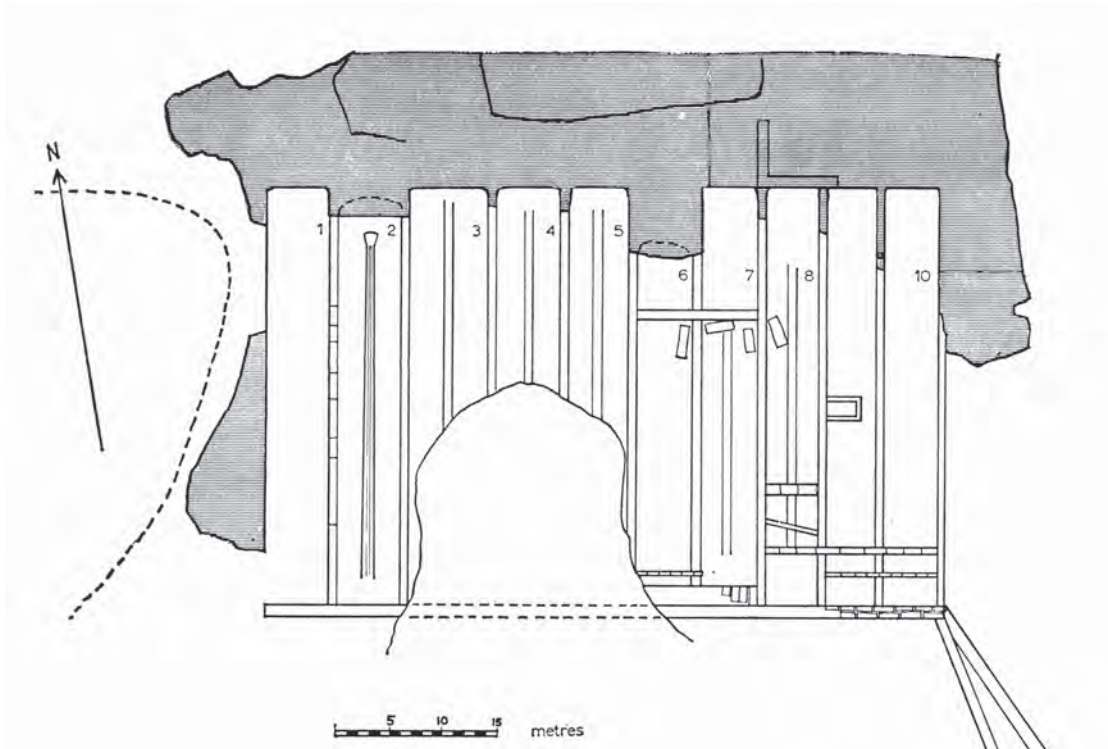

Fig. 50 Apollonia, plan of shipsheds 1–10 (Flemming 1965: fig. 69).

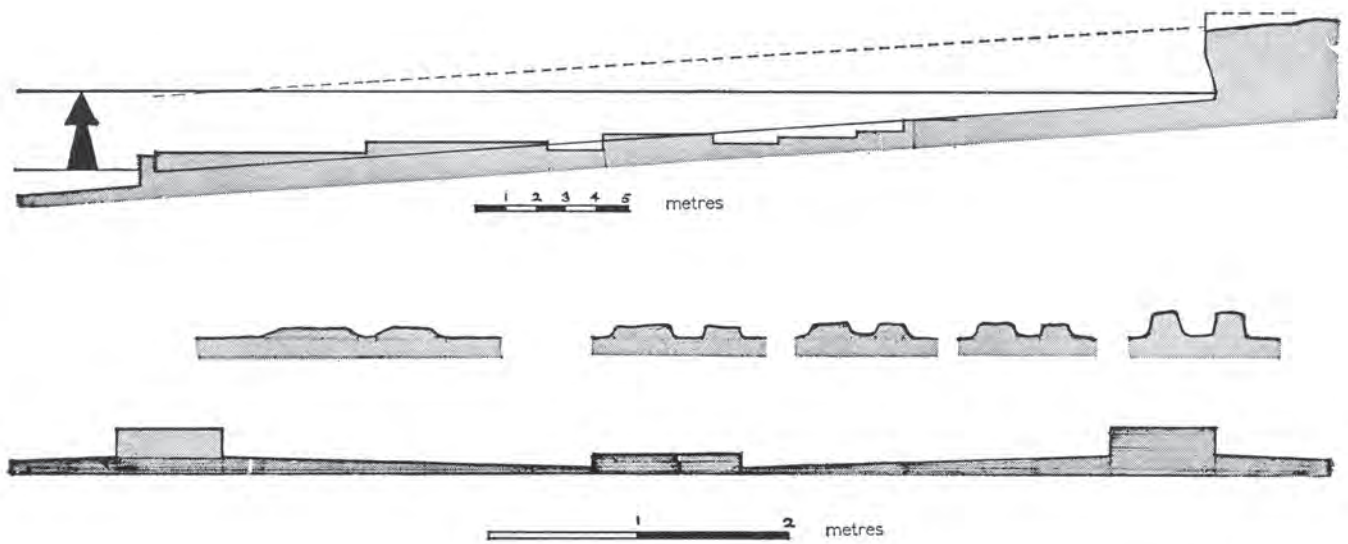

Fig. 51 Apollonia, longitudinal- and cross-sections of shipshed 2 (Flemming 1965: fig. 70).

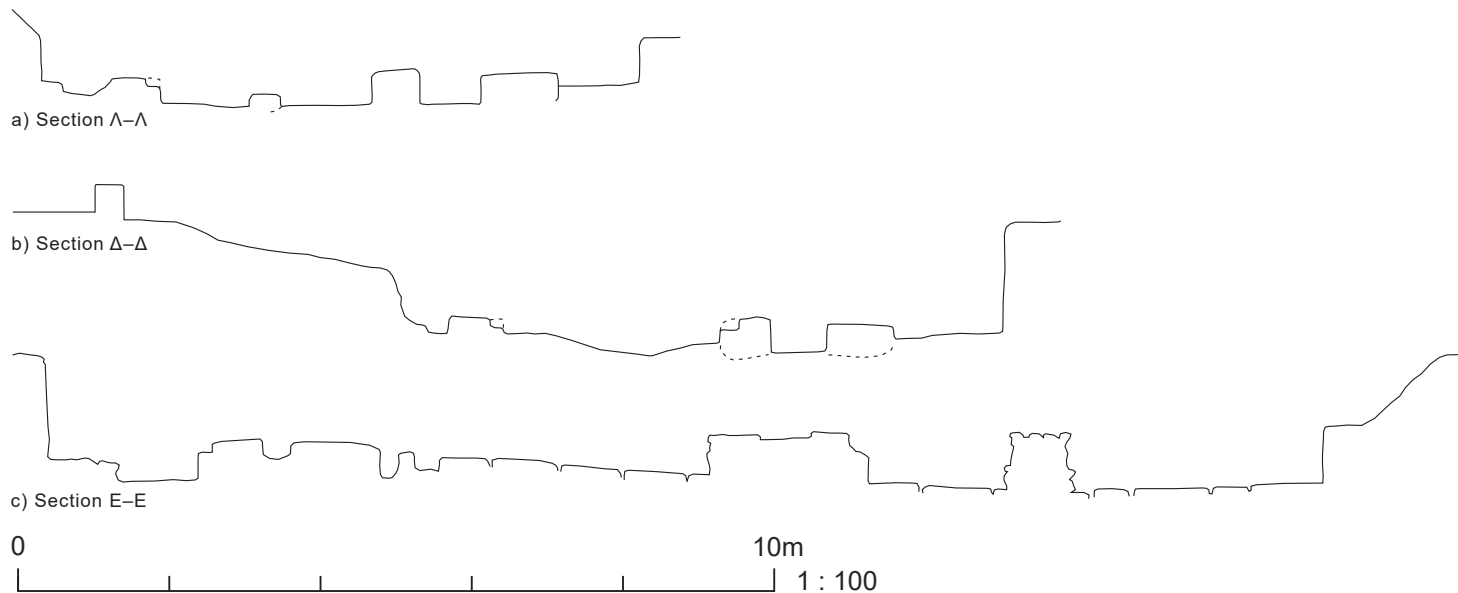

Fig. 52 Kos, plan of shipsheds (Liannos 1999: fig. 6), including sections Λ - Λ , Δ - Δ , and E-E (re-scaled at 1:100; traced by B. Klejn-Christensen from Kantzia 1987: fig. 12). Locations of section markers on plan are approximate.

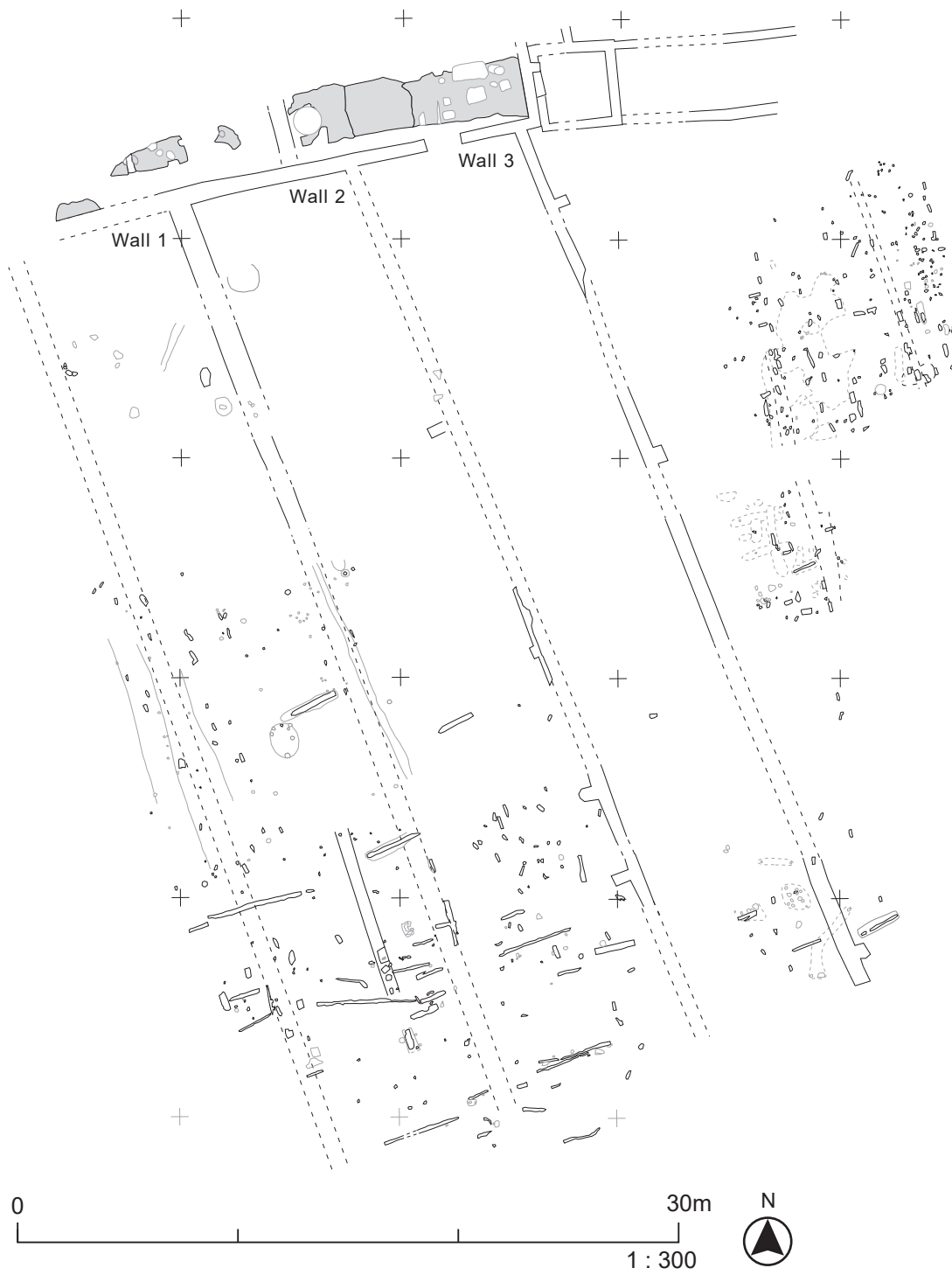

Fig. 53 Marseille, detail of slipways and possible shipsheds at Place Villeneuve-Bargemon (traced by B. Klejn-Christensen from Hesnard *et al.* 1999: plan p. 156).



Fig. 54 Marseille, detail of slipways at Place Jules-Verne traced by B. Klejn-Christensen from Hesnard *et al.* 1999: plan p. 156).



Fig. 55 Zea, Group 1, Shiphsheds 20(π), 21(Δ), 22(N) and 23(Π). The house Sirangiou 2 is visible in the background. From north-west (Dörpfeld? March 1891, PIR6 ©DAI).



Fig. 56 Sirangiou 2 from north-west (M.M. Nielsen ©ZHP 2005).



Fig. 57 Zea, Group 1, detail of raised rock-cut foundations of Back-wall section 5. From north-west (Dörpfeld? March 1891, PIR6 ©DAI).



Fig. 58 Zea, Group 1, Phase 3, Back-wall section 2 (lower right), probable column drum (centre, behind wall), Sirangiou 2 (upper left) (©Historical Archive of the Piraeus).



Fig. 59 Zea, Group 1, Phase 3, upper ends of Shipsheds 16, 17(η) and 18(χ) (right).
From south-west (commissioned by I.A. Meletopoulos ©Piraeus Historical Archive).



Fig. 60 Zea, Group 1, Phase 3, upper ends of Shipsheds 16, 17(η) and 18(χ) (right).
From south-west (commissioned by I.A. Meletopoulos ©Piraeus Historical Archive).



Fig. 61 Zea, Group 1, Phases 3 and 4, upper ends of Shipsheds 16, 17(η) and 26(?) (left). From north-west (commissioned by I.A. Meletopoulos ©Piraeus Historical Archive).



Fig. 62 Zea, Group 1, Phases 3 and 4, upper ends of Shipsheds 16, 17(η), 18(χ) and 26(?) (left). From north-west (commissioned by I.A. Meletopoulos ©Piraeus Historical Archive).



Fig. 63 Zea, Group 1, Phase 3, raised rock-cut foundations of wall dividing Shipsheds 16/26(λ) (commissioned by I.A. Meletopoulos ©Piraeus Historical Archive).



Fig. 64 Zea, probably Group 1, column drum (commissioned by I.A. Meletopoulos ©Piraeus Historical Archive).



Fig. 65 Surveyor 'shooting' directly to a feature aided by a 'pointer'
(M. McCallum ©ZHP 2005).



Fig. 66 Surveyor 'shooting' to a EDM prism pole. Diver 'points' to a feature,
while the pole is aligned by the 'prism person' (B. Lovén ©ZHP 2006).



Fig. 67 Zea, Group 1, Phase 3, Back-wall section 2a. From the north-west (K. Lovén ©ZHP 2002).



Fig. 68 Zea, Group 1, Phase 3, Spur-wall C17/18(γ). From the north (M.M. Nielsen ©ZHP 2006).



Fig. 69 Zea, Group 1, Phase 3, Back-wall section 2a, and Spur-wall C17/18(γ). From the south/south-east (M.M. Nielsen ©ZHP 2006).



Fig. 70 Zea, Group 1, Phase 3, rock-cut foundations of Back-wall section 2a, and Spur-wall C17/18(γ). From the west (M.M. Nielsen ©ZHP 2006).

Fig. 71 Zea, Group 1, Phase 3, Wall 16/26(λ). From east
(K. Lovén ©ZHP 2002).



Fig. 72 Zea, Group 1, Phase 3, intersection between Back-wall (BW:1) and W16/26:1. From south (M.M. Nielsen ©ZHP 2006).





Fig. 74 Zea, Group 1, Phase 3, detail of Spur-wall block C17/18:4 tying into Back-wall section 2a. From north-west (M.M. Nielsen ©ZHP 2006).



Fig. 73 Zea, Group 1, Phase 3, colonnade dividing Shipsheds 17(η) and 18(χ). From the west/north-west. Includes southern side-passage and southern edge of the ramp of Shipshed 17(η)(M.M. Nielsen ©ZHP 2006).



Fig. 75 Zea, Group 1, Phase 3, later possible entrance through Back-wall (BW:5-6) (M.M. Nielsen ©ZHP 2006).



Fig. 76 Zea, Group 1, Phase 3, Back-wall, BW:11 (M.M. Nielsen ©ZHP 2006).



Fig. 77 Zea, Group 1, Phase 3, Back-wall, BW:12 (M.M. Nielsen ©ZHP 2006).



Fig. 78 Zea, Group 1, Phase 3, Back-wall, BW:19 (M.M. Nielsen ©ZHP 2006).



Fig. 79 Zea, Group 1, Phase 3, Spur-wall block C17/18:3. Detail of incised half circle(?) (M.M. Nielsen ©ZHP 2006).



Fig. 80 Zea, Group 1, Phase 3, Spur-wall block C17/18:5. Detail of incised arrow (M.M. Nielsen ©ZHP 2006).

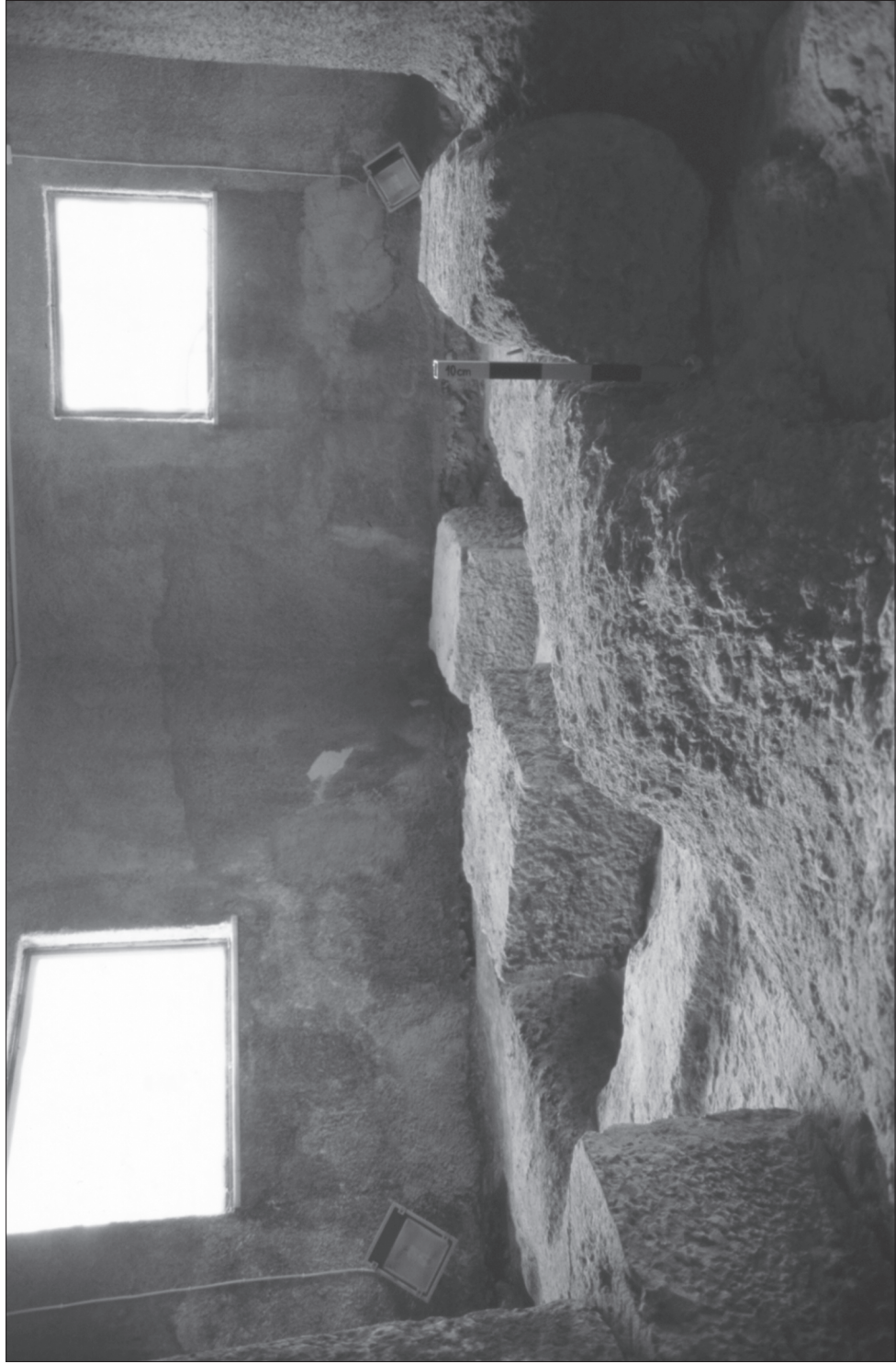

Fig 81 Zea, Group 1, Phase 3, Shipshed 17(η), southern side of ramp, southern side-passage and colonnade dividing Shipsheds 17(η) and 18(χ). From north-east (K. Lovén ©ZHP 2002).

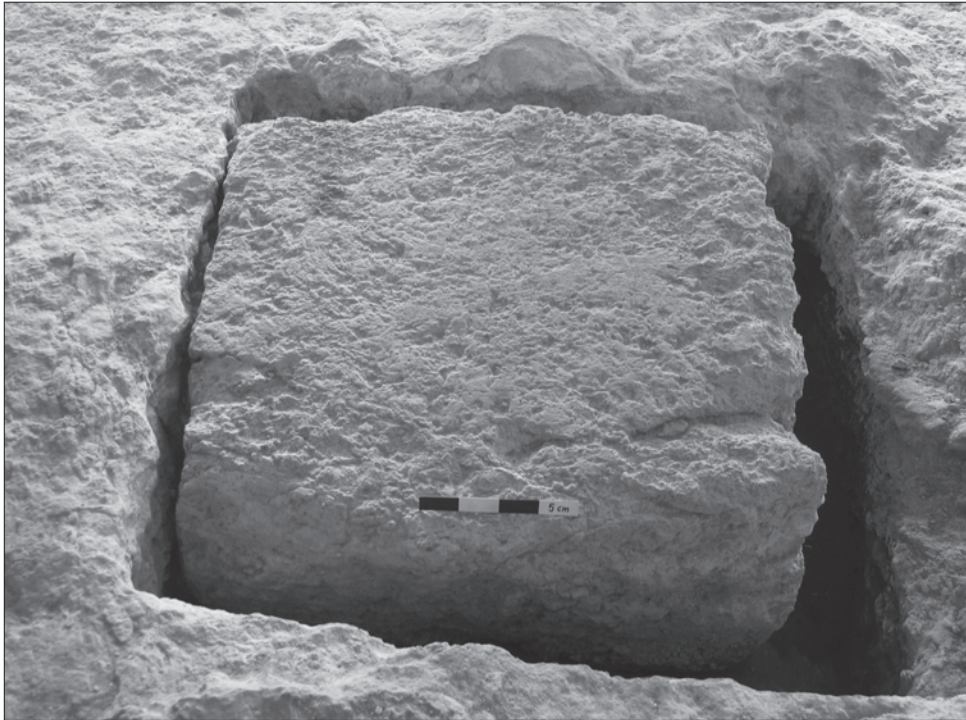

Fig. 82 Zea, Group 1, Phase 3, Column base C16/17:2(Θ) in rock-cut foundation trench C16/17:1 (M.M. Nielsen ©ZHP 2006).



Fig. 83 Zea, Group 1, Phase 3, Column base C16/17:4(t) in rock-cut foundation trench C16/17:3 (M.M. Nielsen ©ZHP 2006).

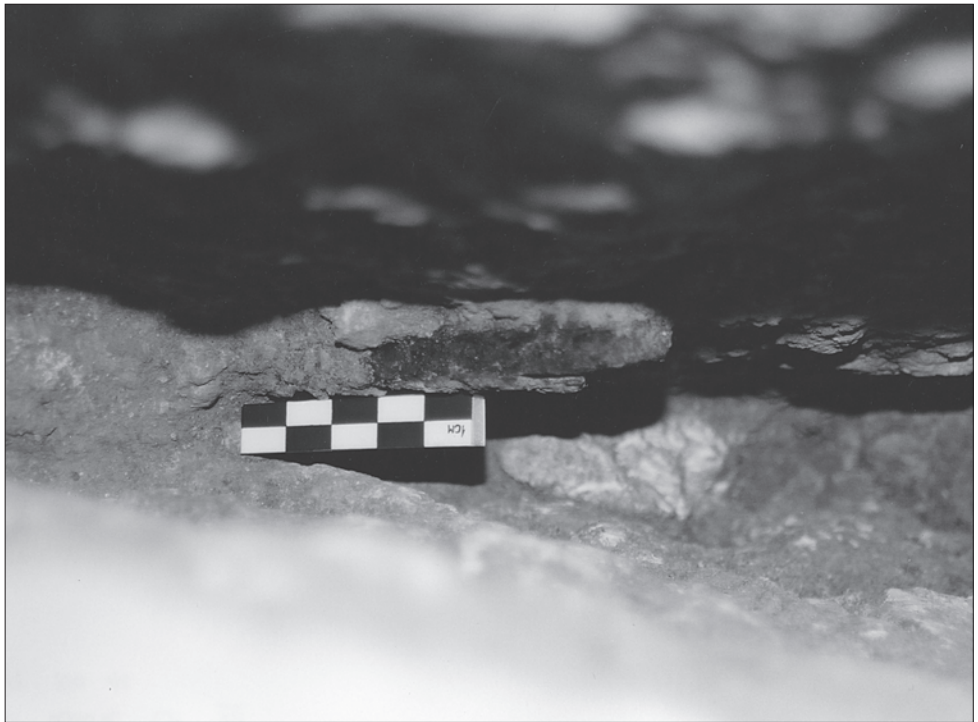

Fig. 84 Zea, Group 1, part of broken iron pry-bar(?), west side of C16/17:2(Θ)
(M.M. Nielsen ©ZHP 2006).



Fig. 85 Zea, Group 1, Phase 3, Column base C17/18:11(ζ) (M.M. Nielsen ©ZHP
2006).



Fig. 86 Zea, Group 4, column drum A/A 1189/VI (K. Lovén ©ZHP 2002).



Fig. 87 Zea, Group 4, bottom of column drum A/A 1189/VI (K. Lovén ©ZHP 2002).



Fig. 88 Zea, Group 4, column drum A/A 1189/V (K. Lovén ©ZHP 2002).

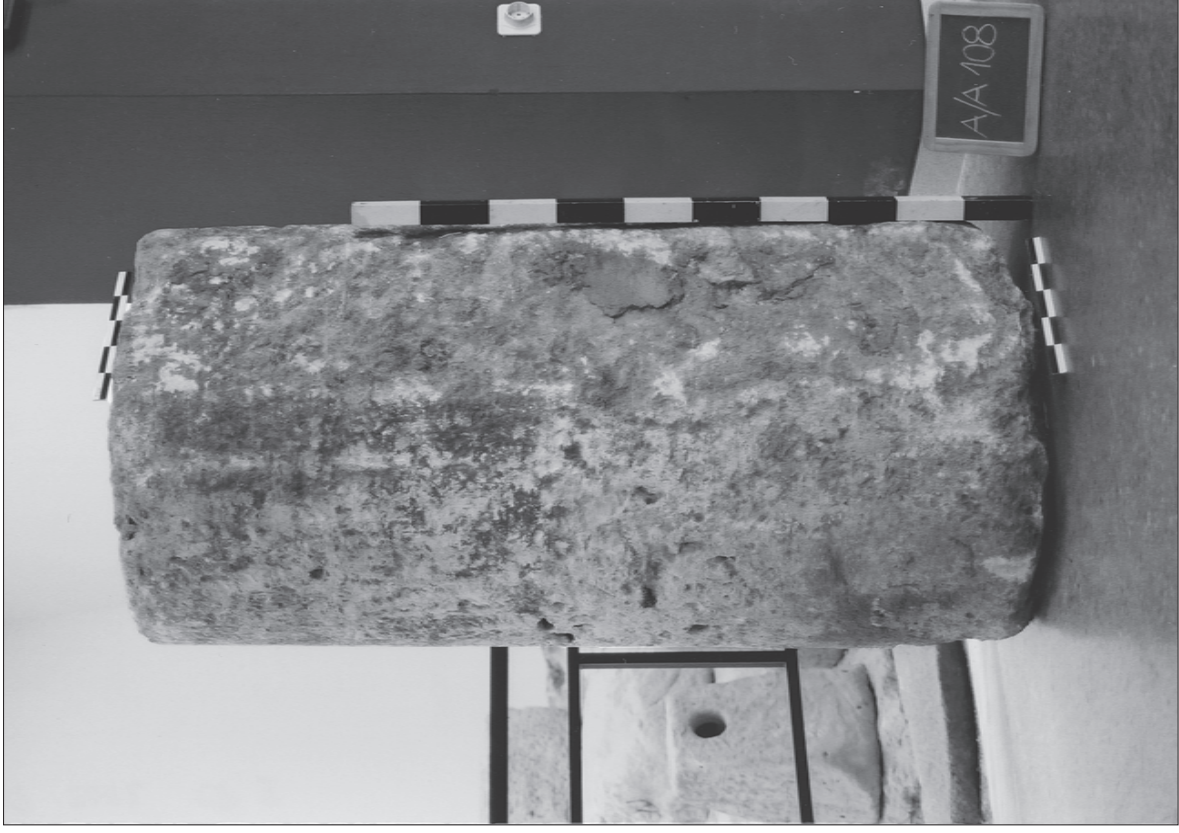

Fig. 89 Zea, Group 4, column drum A/A 108 (K. Lovén ©ZHP 2002).



Fig. 90 Zea, Group 4, bottom of column drum A/A 1189/CI (K. Lovén ©ZHP 2002).

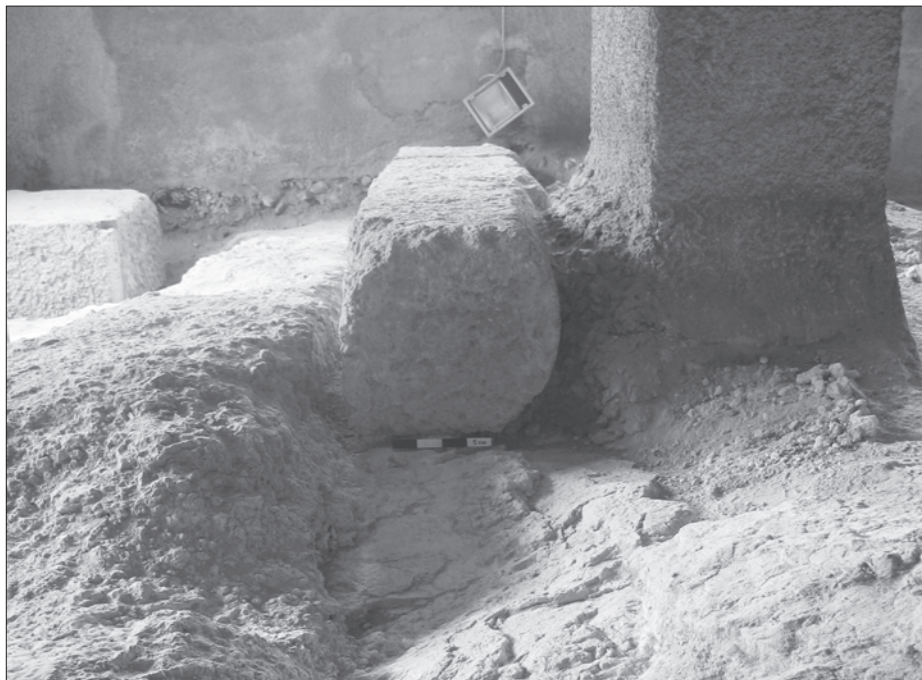

Fig. 91 Zea, Group 1, Phase 3, column drum (S17:R11) re-used in the ramp of Shipshed 17(η) (M.M. Nielsen ©ZHP 2006).



Fig. 92 Zea, Group 1, Phase 3, Shipsheds 16 and 17(η). From north (M.M. Nielsen ©ZHP 2006).

Fig. 93 Zea, Group 1, Phase 3, Shipshed 16, detail of rock-cut ramp foundations S16:R2-R6. From east (M.M. Nielsen ©ZHP 2006).



Fig. 94 Zea, Group 1, Phase 3, Shipshed 17(η), southern side of ramp, including southern side-passage. From east (M.M. Nielsen ©ZHP 2006).





Fig. 95 Zea, Group 1, Phase 3, Architectural Element 1 (M.M. Nielsen ©ZHP 2006).



Fig. 96 Zea, Group 1, Phase 3, Architectural Element 3 (M.M. Nielsen ©ZHP 2006).



Fig. 97 Zea, Group 1, Phase 3, AE:5 lying atop the fill U:1 (M.M. Nielsen ©ZHP 2006).

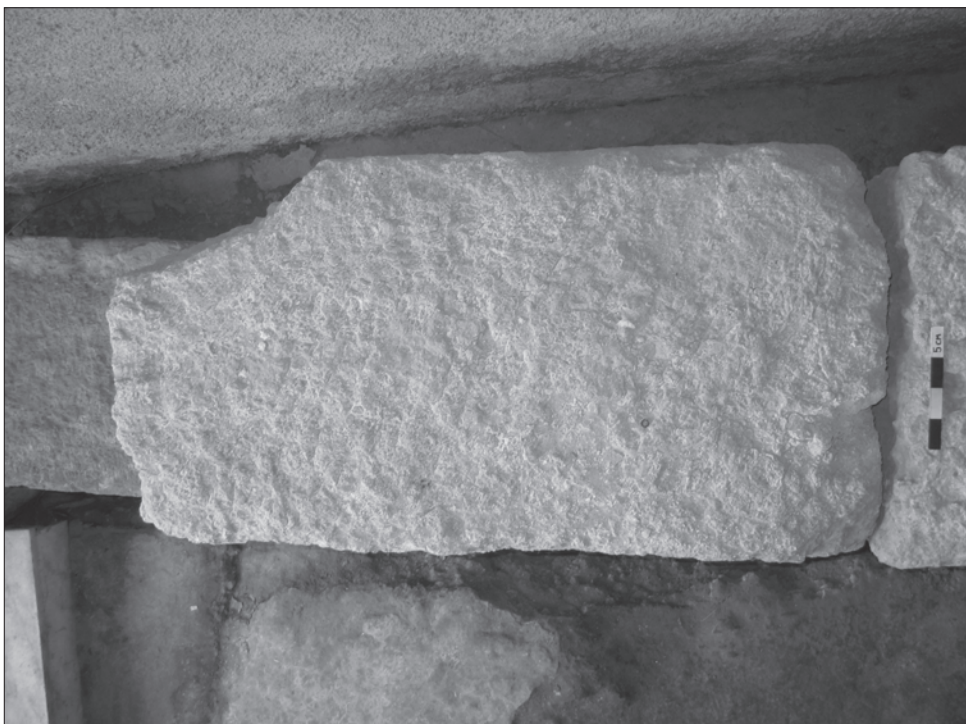

Fig. 98 Zea, Group 1, Phase 3, Architectural Element 5 (M.M. Nielsen ©ZHP 2006).

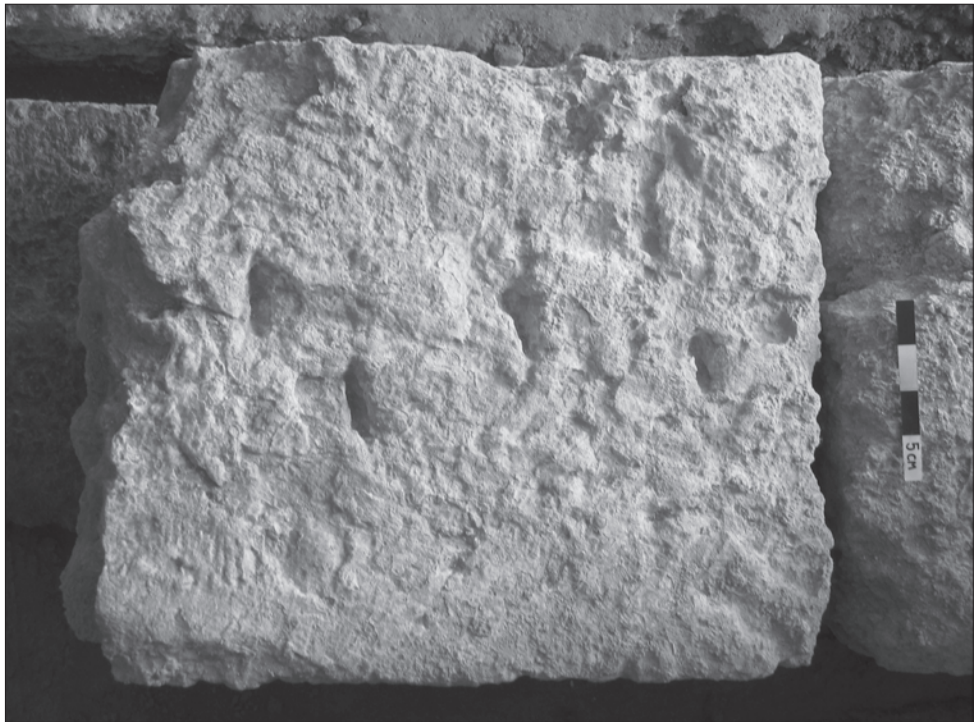

Fig. 99 Zea, Group 1, Phase 3, Architectural Element 4 (M.M. Nielsen ©ZHP 2006).



Fig. 100 Zea, Group 1, Phase 3, Architectural Element 8 (M.M. Nielsen ©ZHP 2006).



Fig. 101 Zea, Group 1, Phase 3, Architectural Element 9 (M.M. Nielsen ©ZHP 2006).



Fig. 102 Zea, Group 1, Phase 3, Architectural Element 10 (M.M. Nielsen ©ZHP 2006).



Fig. 103 Zea, Group 1, Phase 3, Architectural Element 11 (M.M. Nielsen ©ZHP 2006).

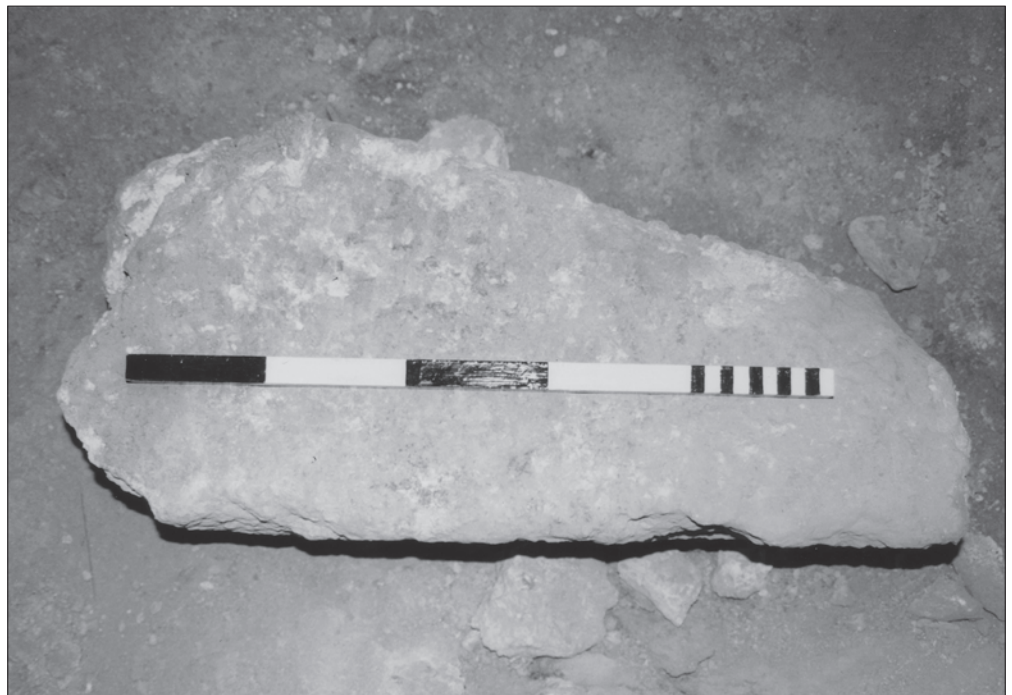
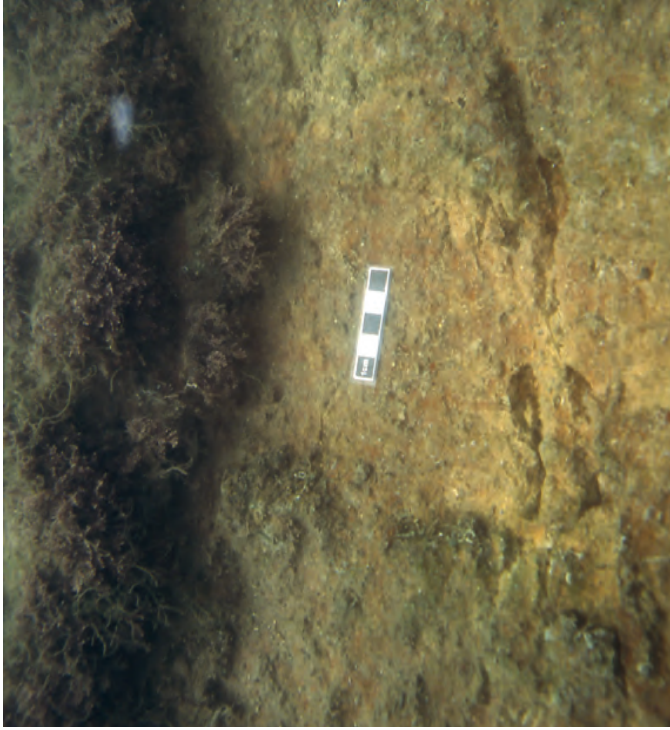

Fig. 104 Zea, Group 1, Phase 3, Architectural Element 12 (B. Loven ©ZHP 2002).

Fig. 105 SW2:R2 from north (B. Lovén ©ZHP 2006).



Fig. 106 SW2:R3 from north (B. Lovén ©ZHP 2006).



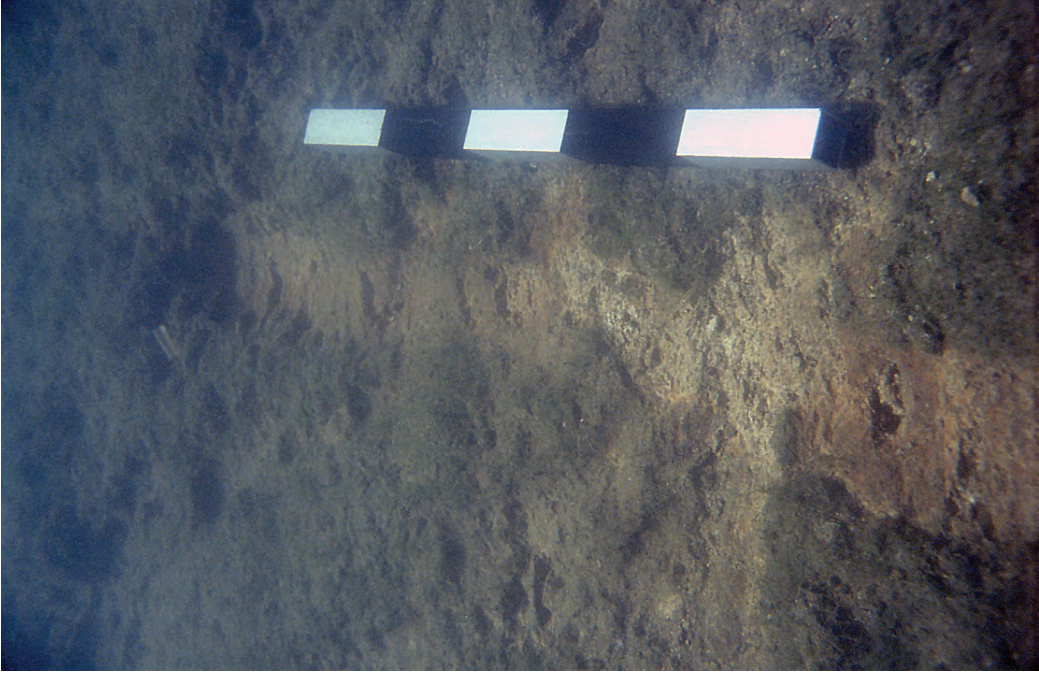

Fig. 107 SW2:R4 from north (B. Lovén ©ZHP 2006);

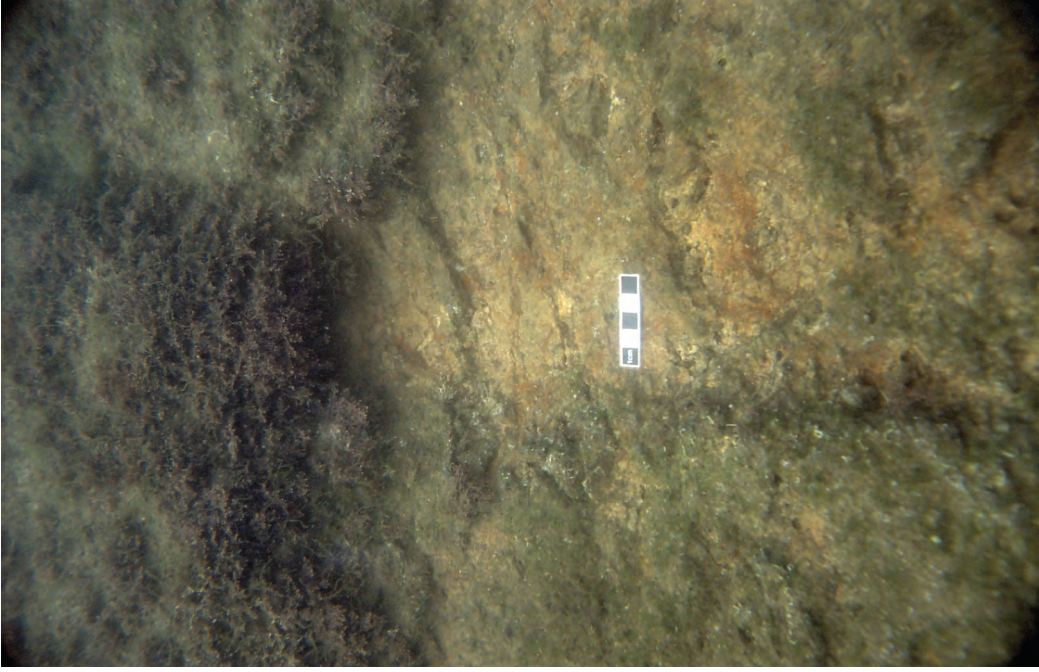

Fig. 108 SW2:R5 from north (B. Lovén ©ZHP 2006).

Fig. 109 SW2:R6 from north (B. Lovén ©ZHP 2006).

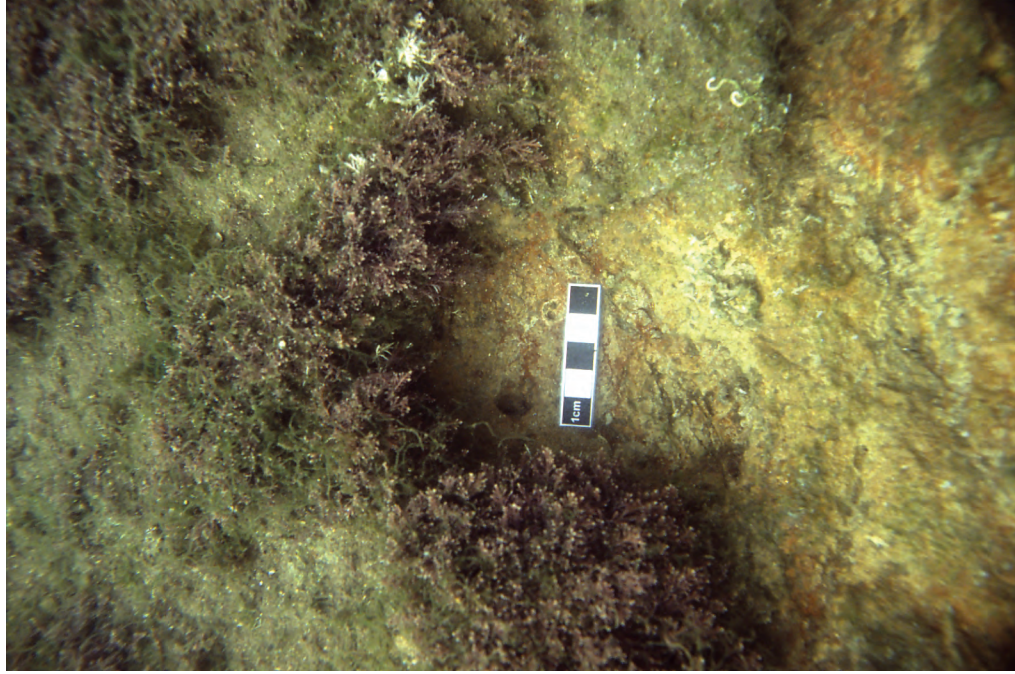

Fig. 110 SW2:R7 from north (B. Lovén © ZHP 2006).





Fig. 111 Zea, Area 1, Slipway 3 and Shipshed 10 from east (B. Lovén ©ZHP 2006).

Fig. 112 SW3:R1 from north (B. Lovén ©ZHP 2006).

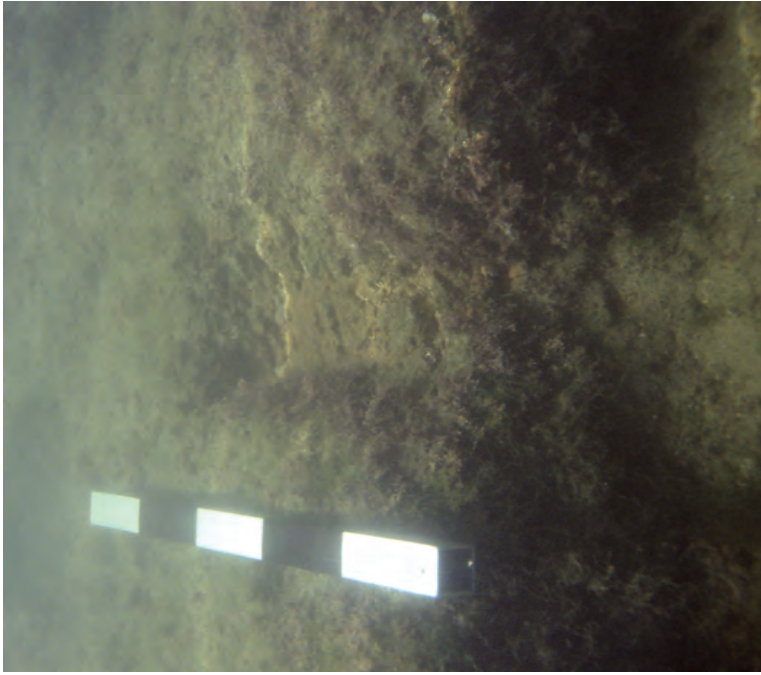
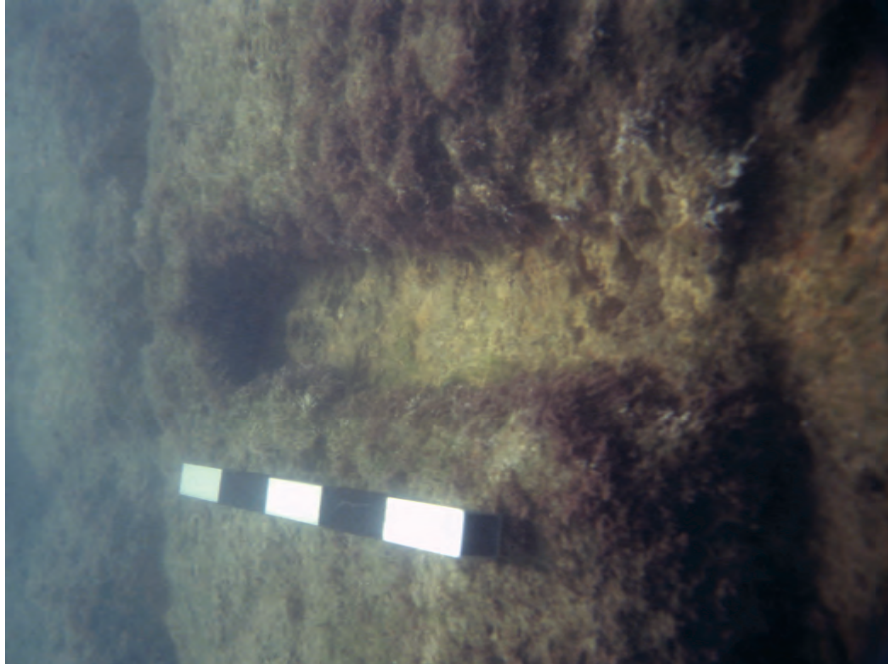

Fig. 113 SW3:R3 from north (B. Lovén ©ZHP 2006).



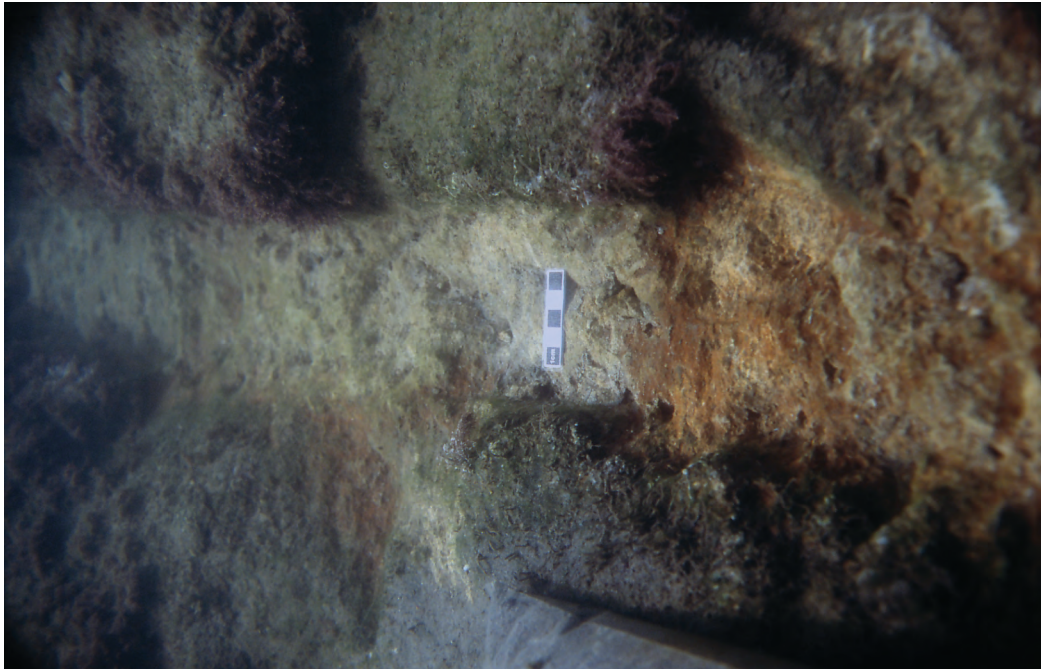

Fig. 114 SW3:R4 from north (B. Lovén ©ZHP 2006).

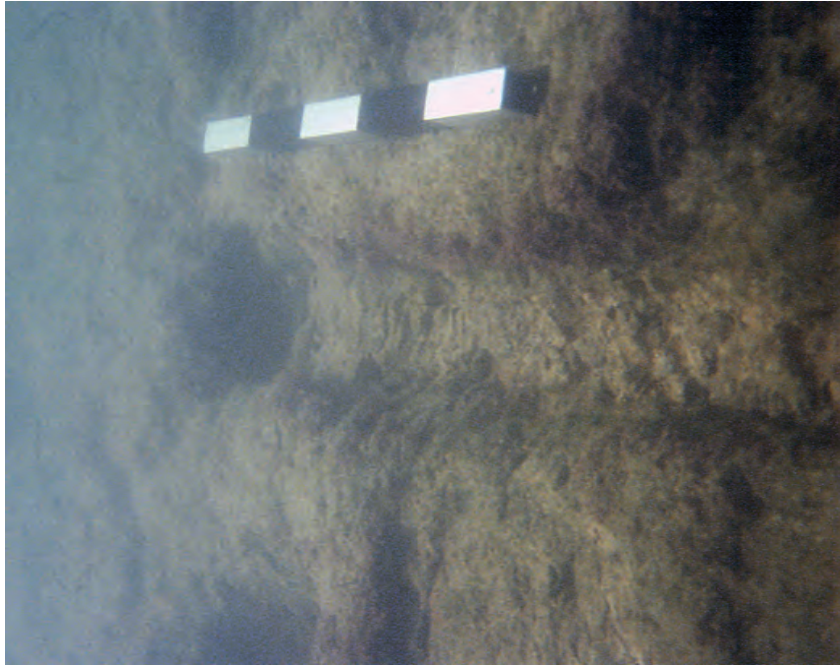

Fig. 115 SW3:R5 from north (B. Lovén ©ZHP 2006).

Fig. 117 SW3:R7 from north (B. Lovén ©ZHP 2006).

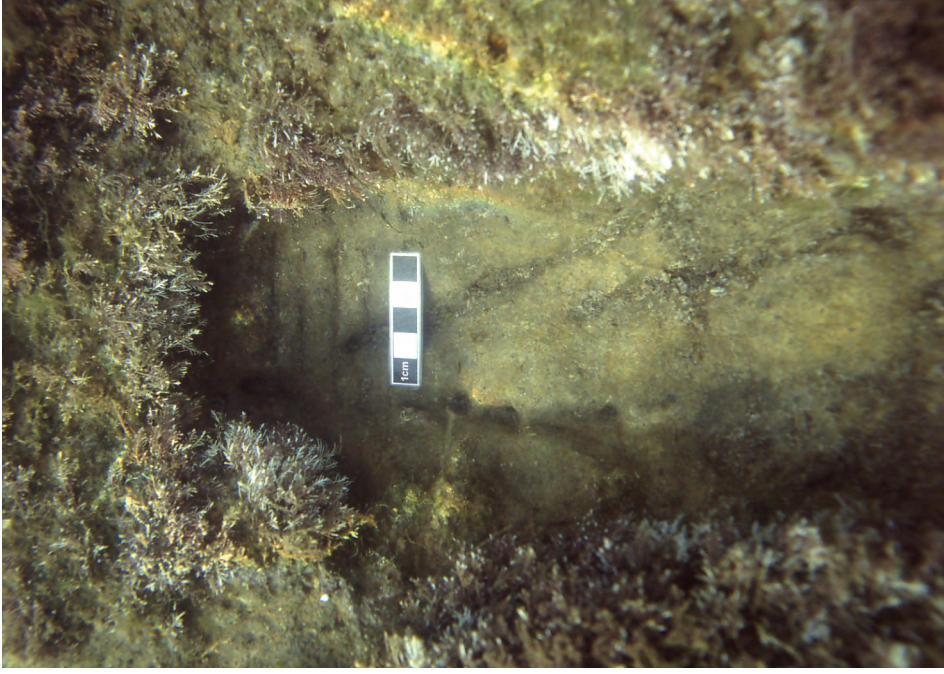
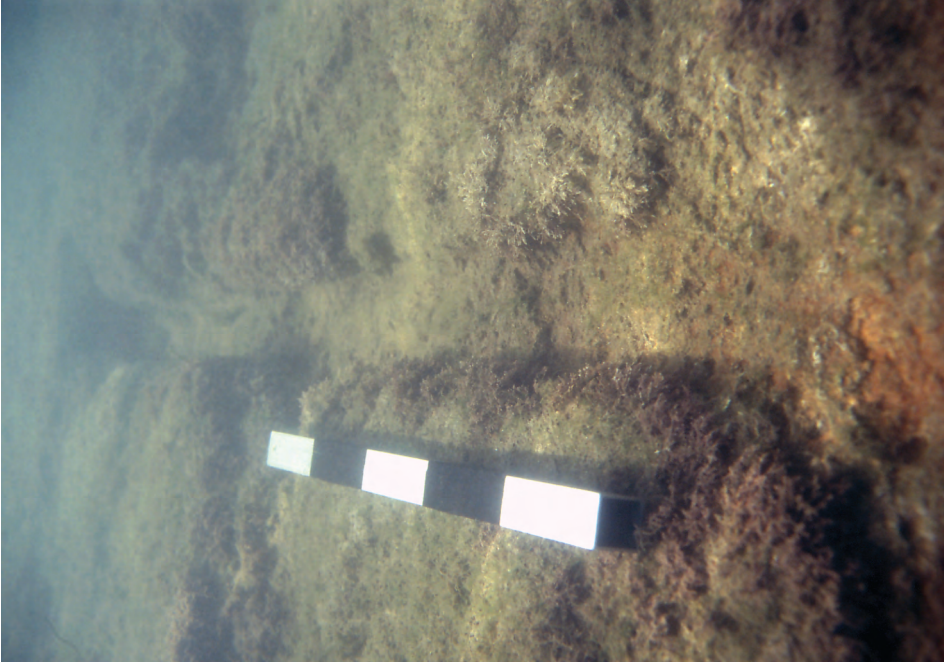

Fig. 116 SW3:R6 from north (B. Lovén ©ZHP 2006).



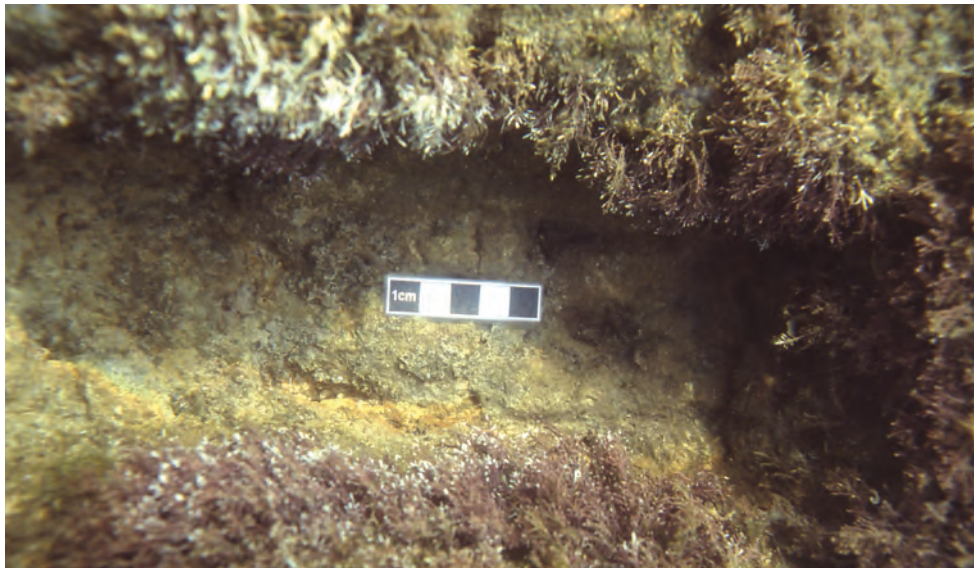

Fig. 118 SW3:R6 from west. Detail of tool marks (B. Lovén ©ZHP 2006).

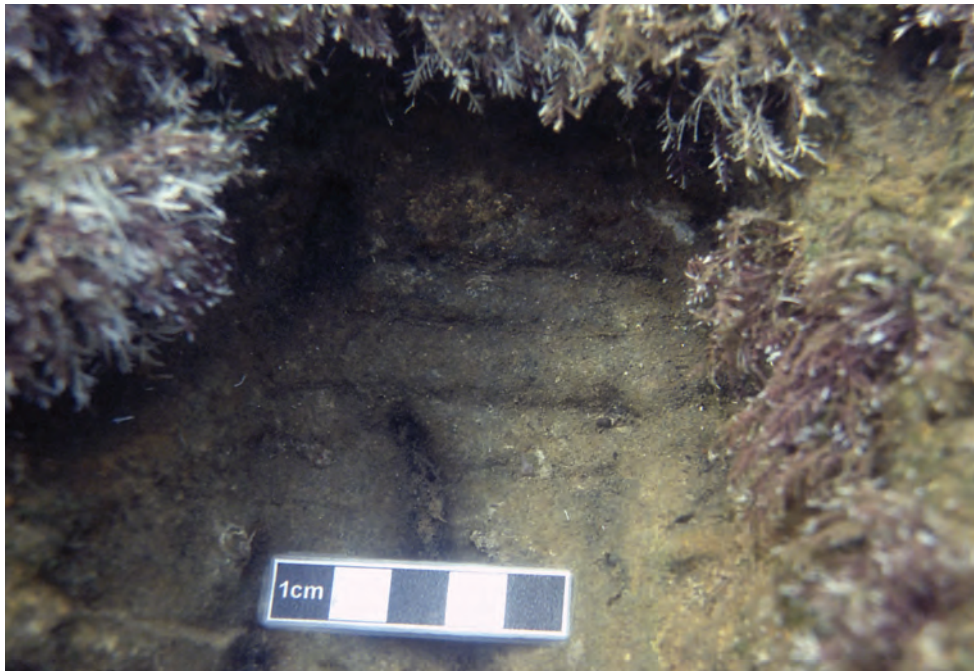

Fig. 119 SW3:R7 from north. Detail of tool marks (B. Lovén ©ZHP 2006).

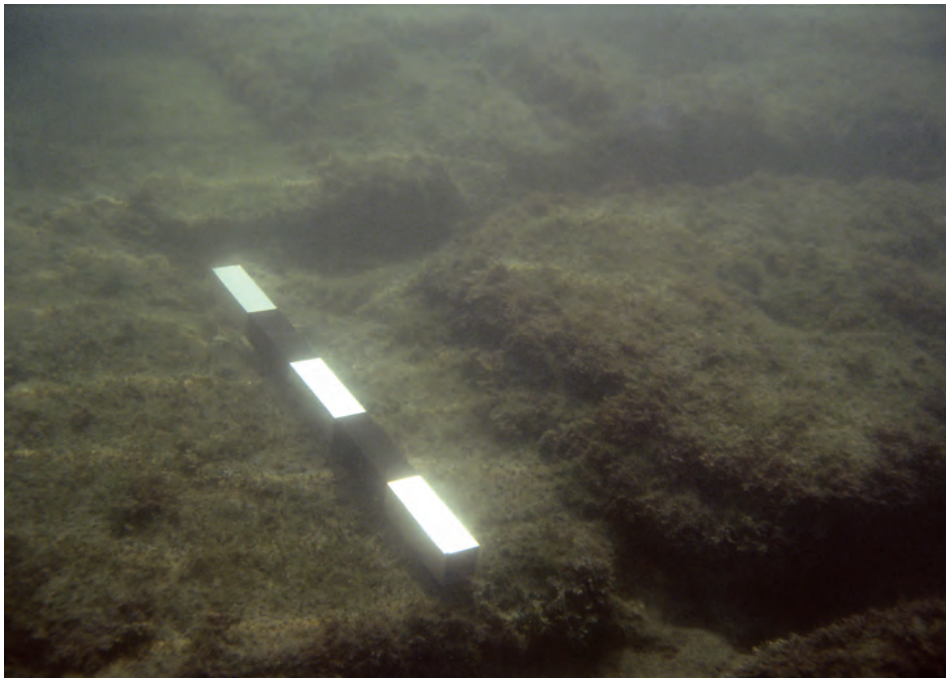

Fig. 120 S10:R2 (left) cutting through SW3:R5 (back) and SW3:R6 (front). From north-west (B. Lovén ©ZHP 2006).



Fig. 121 SW6:R1 and S14:R1 from east (B. Loven ©ZHP 2006).

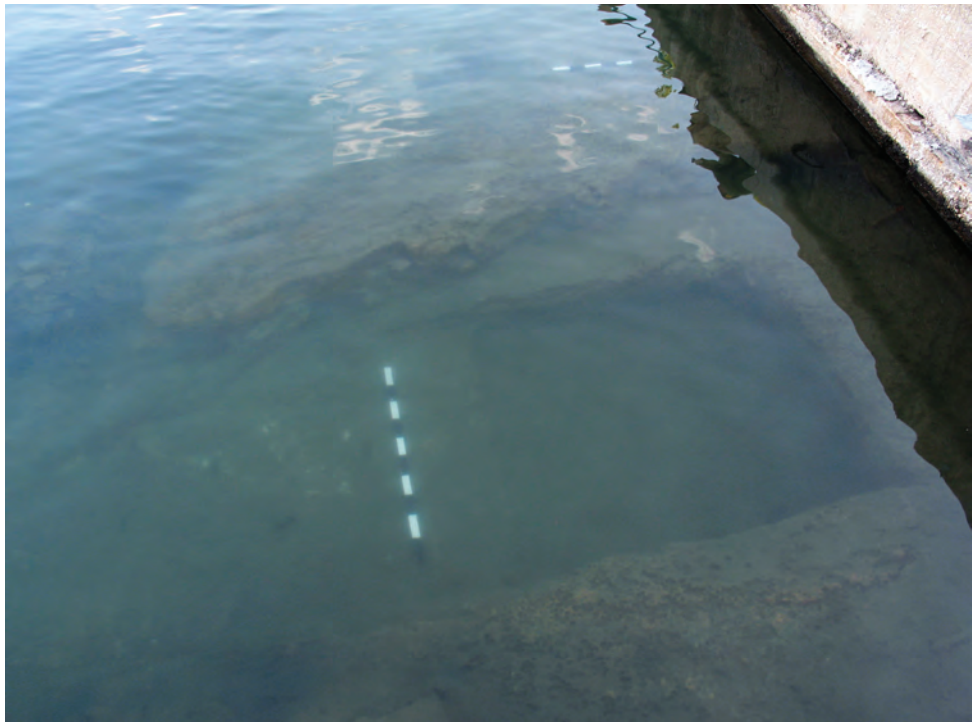

Fig. 122 Zea, Group 1, Phases 2–3, rock-cut colonnade foundation trench C14/15:1 (left) and C23/24:8 (right). From south (B. Lovén ©ZHP 2006).

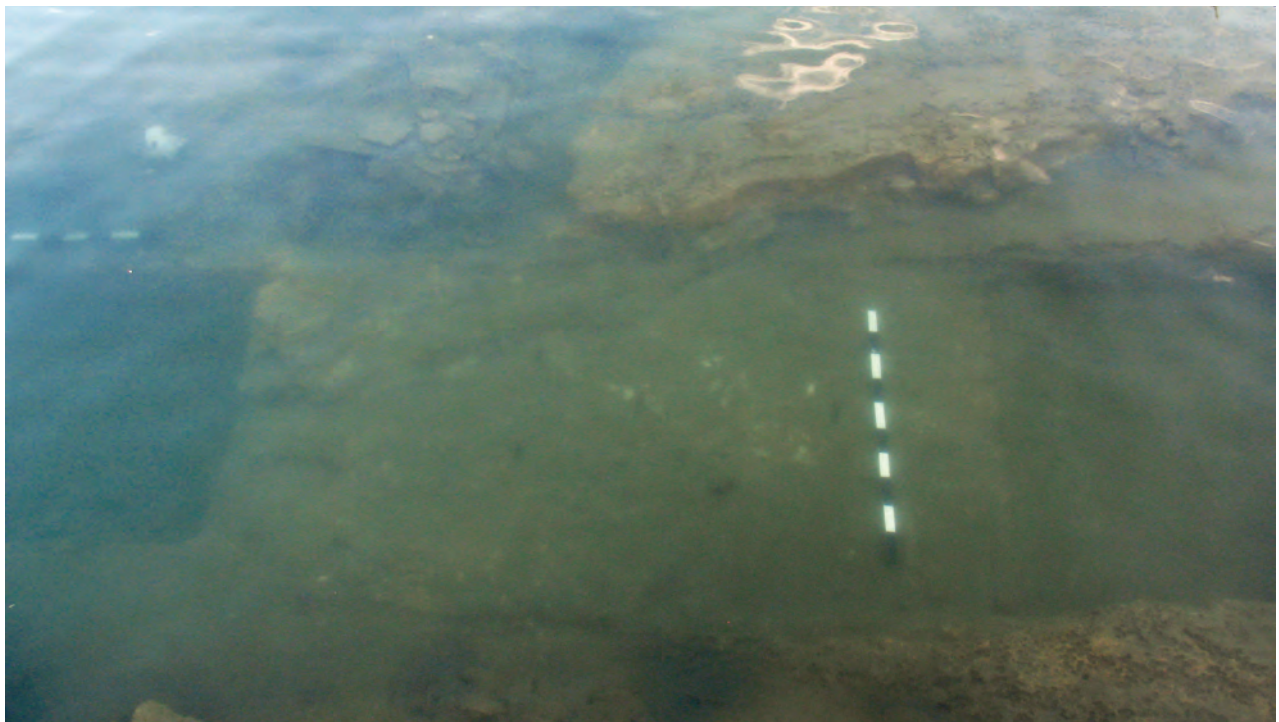

Fig. 123 Zea, Group 1, Phases 2–3, western part of rock-cut colonnade foundation trench C14/15:1 (right), C23/24:8 (centre) and eastern part of C14/15:2, (left). From south (B. Lovén ©ZHP 2006).



Fig. 124 Zea, Area 3, Quarry 3 (left, south), column base foundation trench, ramp foundations (right, north). Most probably Graser's η feature (B. Lovén ©ZHP 2010).



Fig. 125 Zea, Area 3, Quarry 4. From east (B. Lovén ©ZHP 2010).



Fig. 126 The pit U:2 (K. Lovén ©ZHP 2002).



Fig. 127, Cat. 1



Fig. 128, Cat. 2

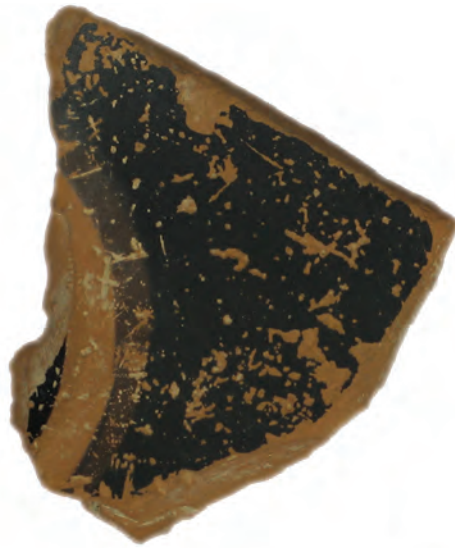

Fig. 129a-b, Cat. 3

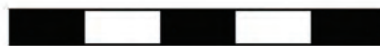

Fig. 130, Cat. 12



Fig. 131a-b, **Cat. 24** (1:2)



Fig. 132, **Cat. 39** (not to scale)



Fig. 133, **Cat. 41** (1:2)



Fig. 134, **Cat. 42** (1:2)



Fig. 135, **Cat. 60** (1:2)



Fig. 136, **Cat. 61** (1:2)



Fig. 137, Cat. 66



Fig. 138, Cat. 67 (1:2)



Fig. 139, Cat. 68



Fig. 140, Cat. 69



Fig. 141a-b, Cat. 70



Fig. 142a-b, Cat. 71



Fig. 143, **Cat. 72** (1:2)



Fig. 144, **Cat. 73** (1:2)



Fig. 145, **Cat. 74** (1:2)



Fig. 146, **Cat. 75** (1:2)



Fig. 147, **Cat. 76** (1:2)



Fig. 149, **Cat. 78**

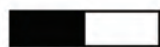

Fig. 150, **Cat. 79** (1:2)



Fig. 148, **Cat. 77** (1:2)



Fig. 151, **Cat. 80** (1:3)



Fig. 152, **Cat. 81**



Fig. 153, **Cat. 82** (1:2)



Fig. 155, **Cat. 84** (1:2)



Fig. 156, **Cat. 85** (1:2)



Fig. 157, **Cat. 86** (1:2)



Fig. 158, **Cat. 87** (1:2)



Fig. 154, **Cat. 83** (1:2)



Fig. 159, **Cat. 88** (1:2)



Fig. 160, **Cat. 89** (1:2)



Fig. 161a-b, **Cat. 90**



Fig. 162, **Cat. 91** (1:2)



Fig. 163a, Cat. 92 (1:2)



Fig. 163b, Cat. 92 (1:2)



Fig. 164, **Cat. 96** (1:2)



Fig. 165, **Cat. 106** (1:2)



Fig. 166, **Cat. 109** (not to scale)

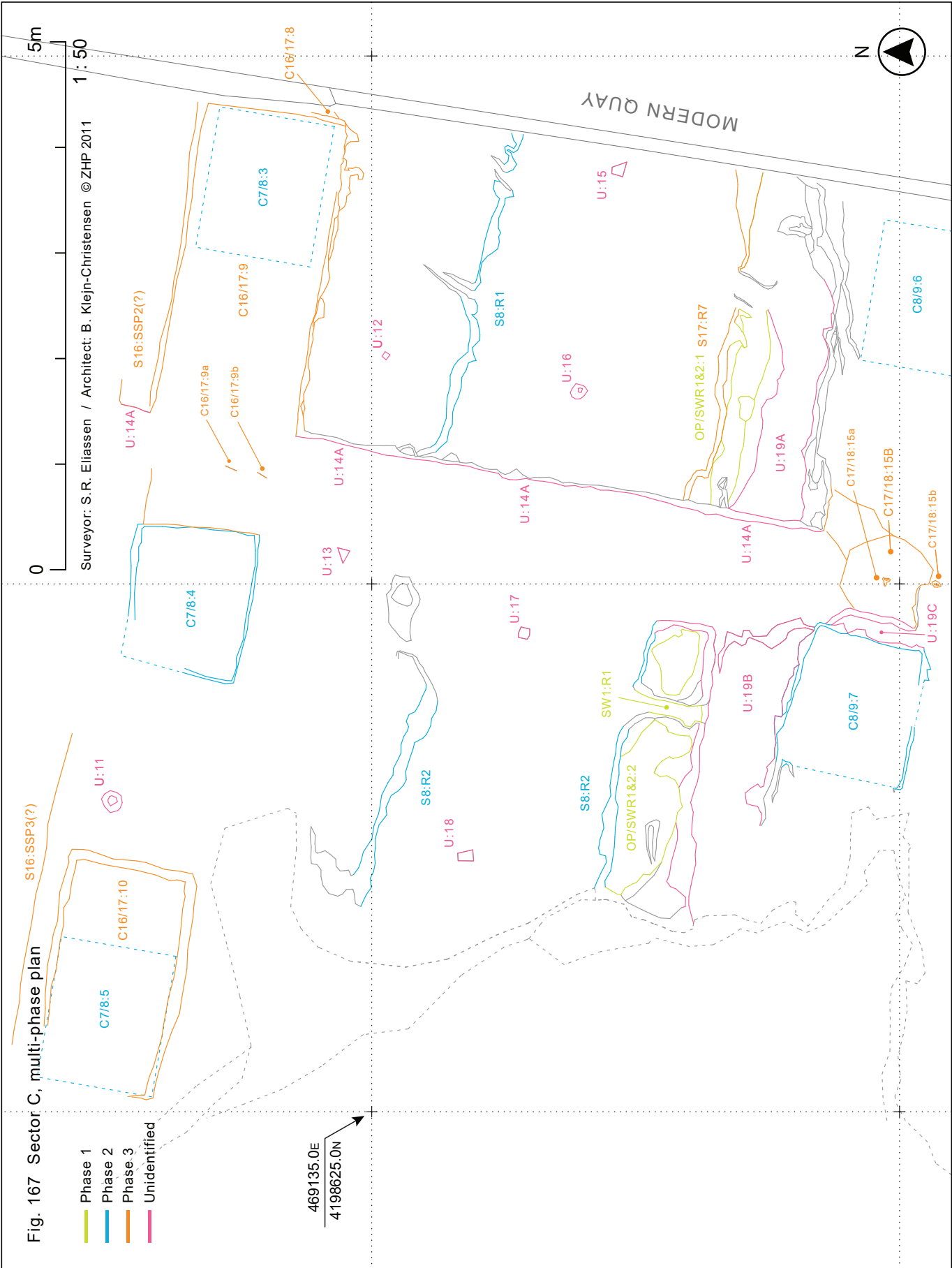

Fig. 167 Sector C, multi-phase plan

- Phase 1
- Phase 2
- Phase 3
- Unidentified

5m

1 : 50

Surveyor: S.R. Eliassen / Architect: B. Klejnh-Christensen © ZHP 2011

0

469135.0E
4198625.0N

MODERN QUAY



Fig. 168 Sector D, multi-phase plan

- Phase 1
- Phase 2
- Phase 3
- Unidentified

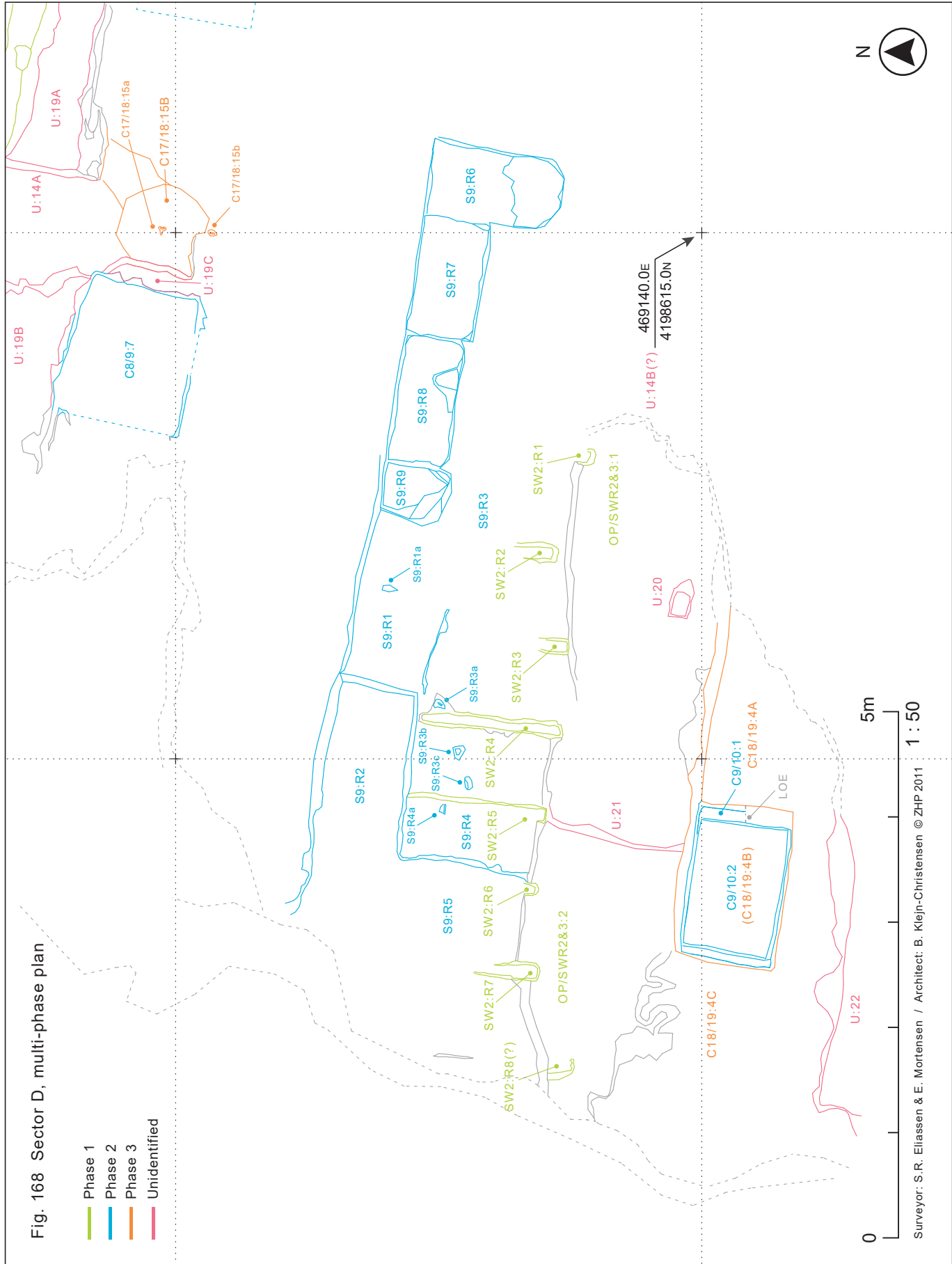

0 5m 1 : 50
 Surveyor: S.R. Eliassen & E. Mortensen / Architect: B. Kleijn-Christensen © ZHP 2011

Fig. 169 Sector E, multi-phase plan

- Phase 1
- Phase 2
- Phase 3
- Unidentified

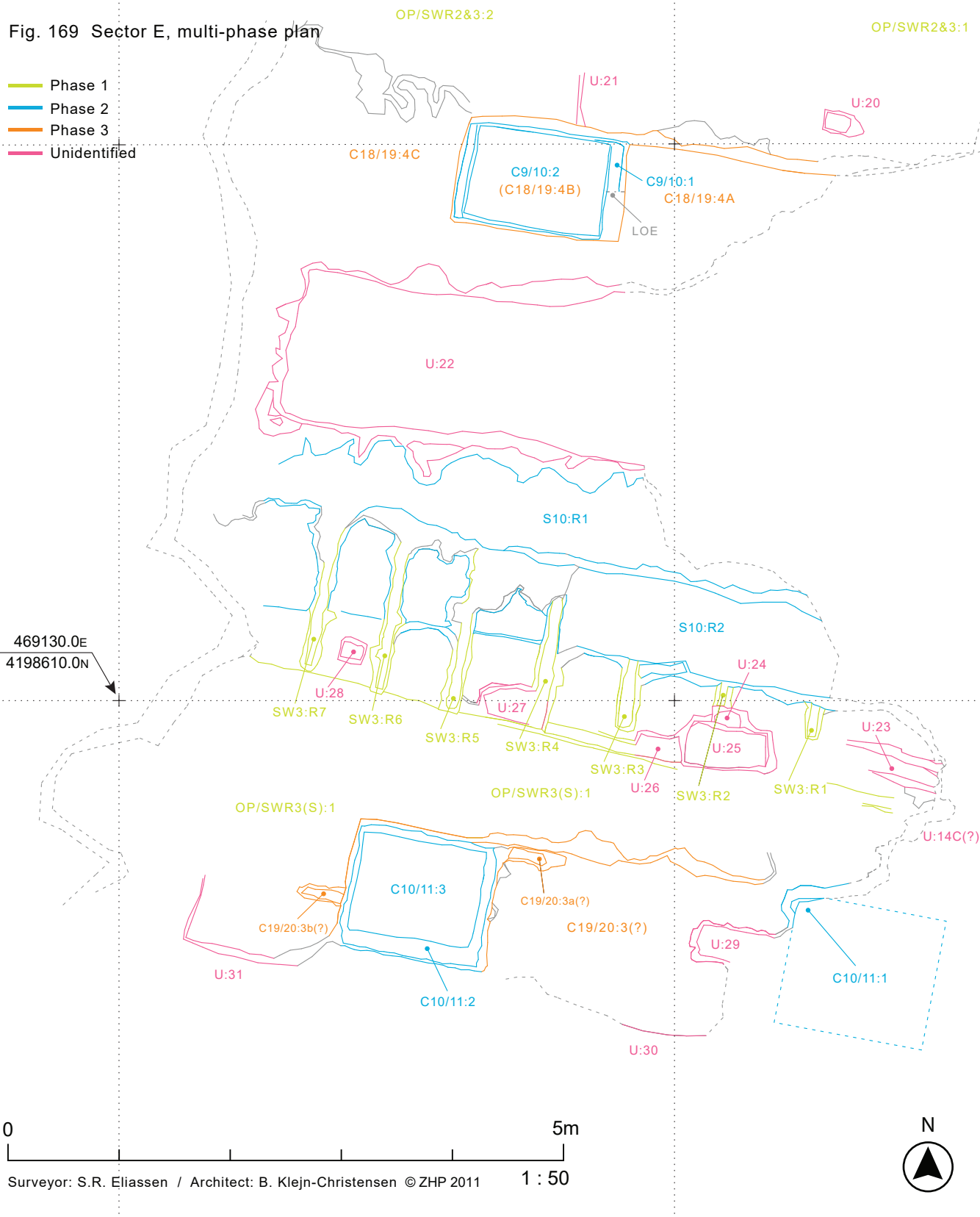
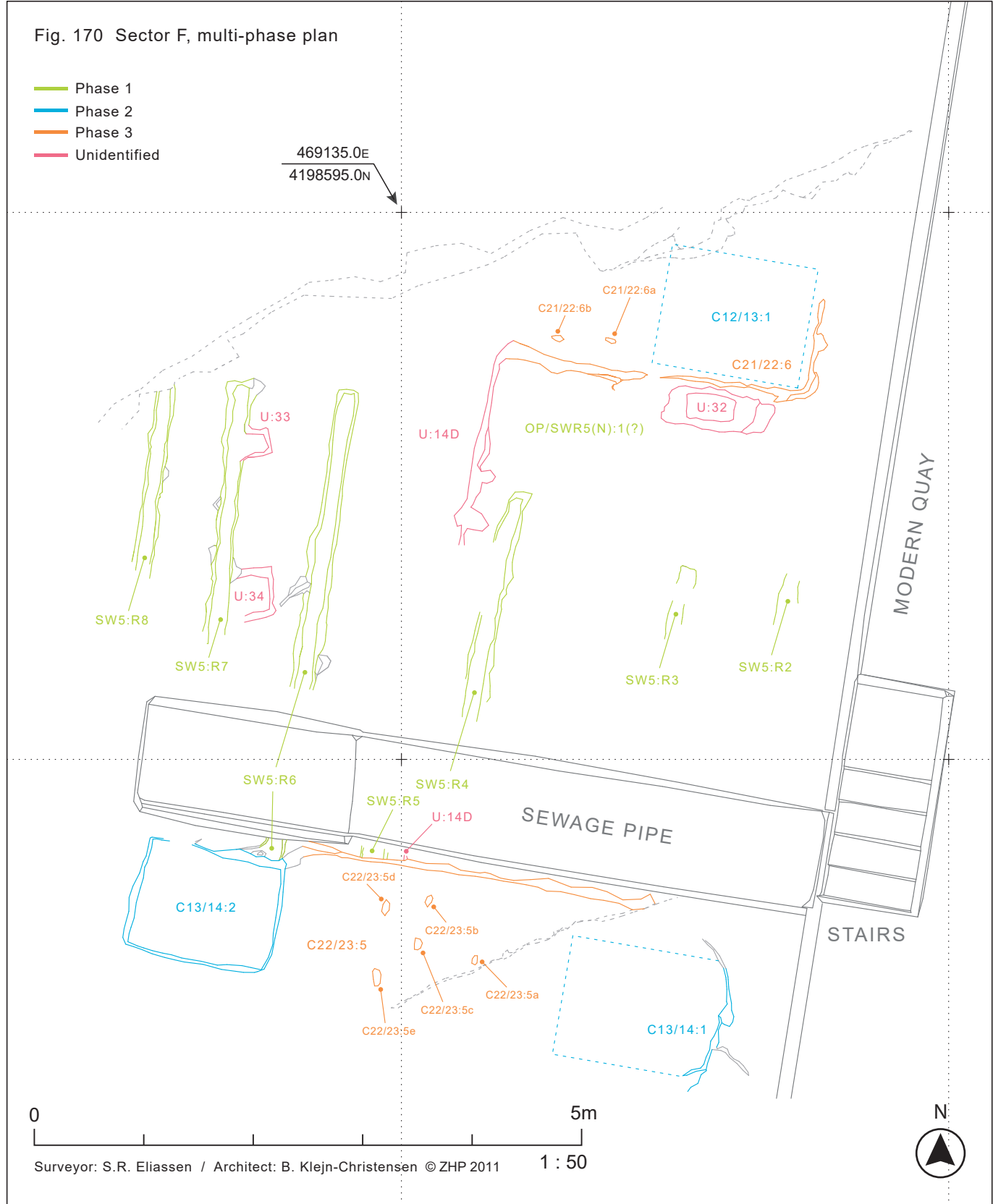

Fig. 170 Sector F, multi-phase plan

- Phase 1
- Phase 2
- Phase 3
- Unidentified



Surveyor: S.R. Eliassen / Architect: B. Klejn-Christensen © ZHP 2011

1 : 50

Fig. 171 Sector G, multi-phase plan

- Phase 1
- Phase 2
- Phase 3
- Unidentified

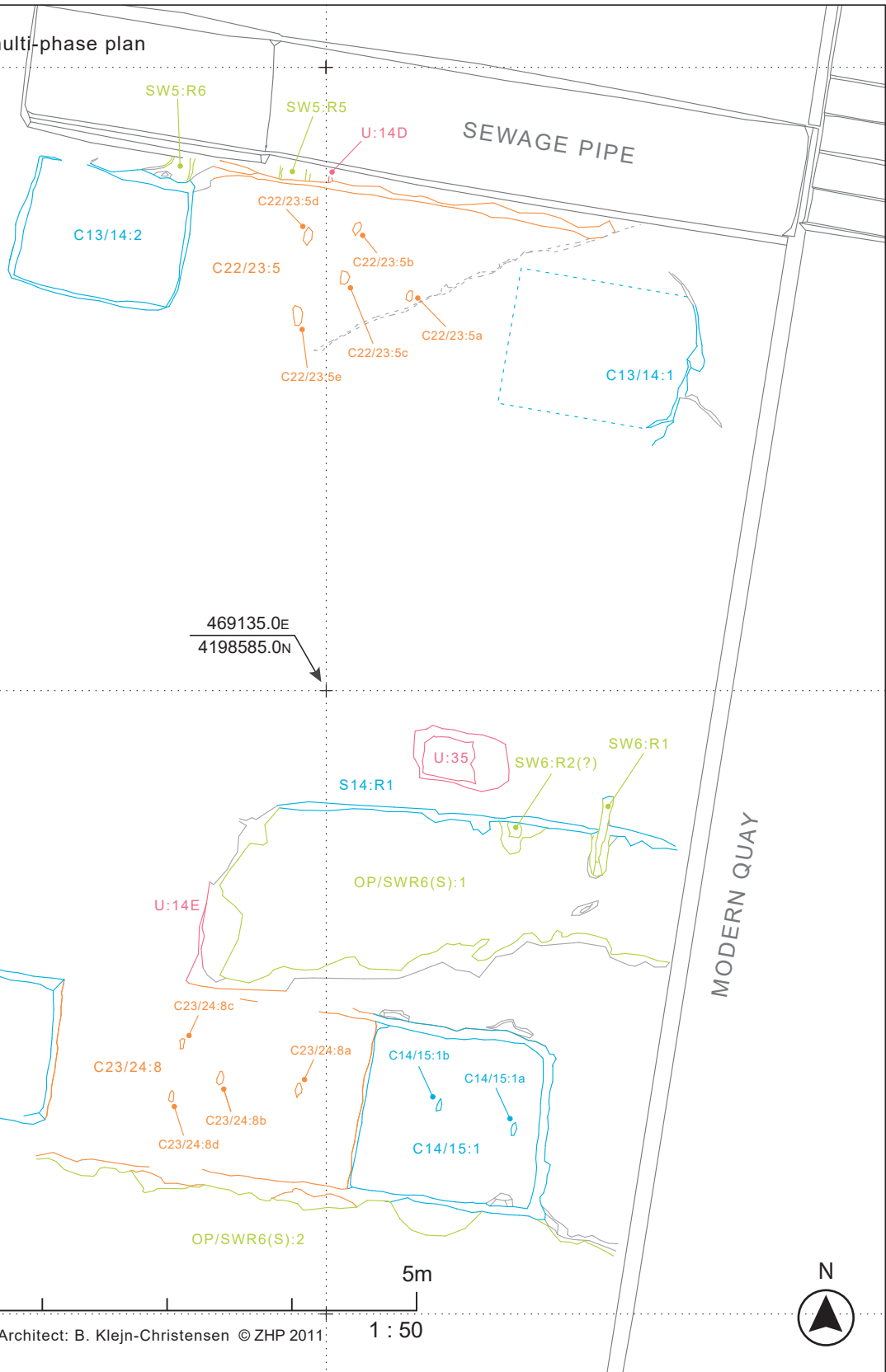

0 5m
 Surveyor: S.R. Eliassen / Architect: B. Klejn-Christensen © ZHP 2011 1 : 50

Fig. 172 Sector H, multi-phase plan

- Phase 1
- Phase 2
- Phase 3
- Unidentified

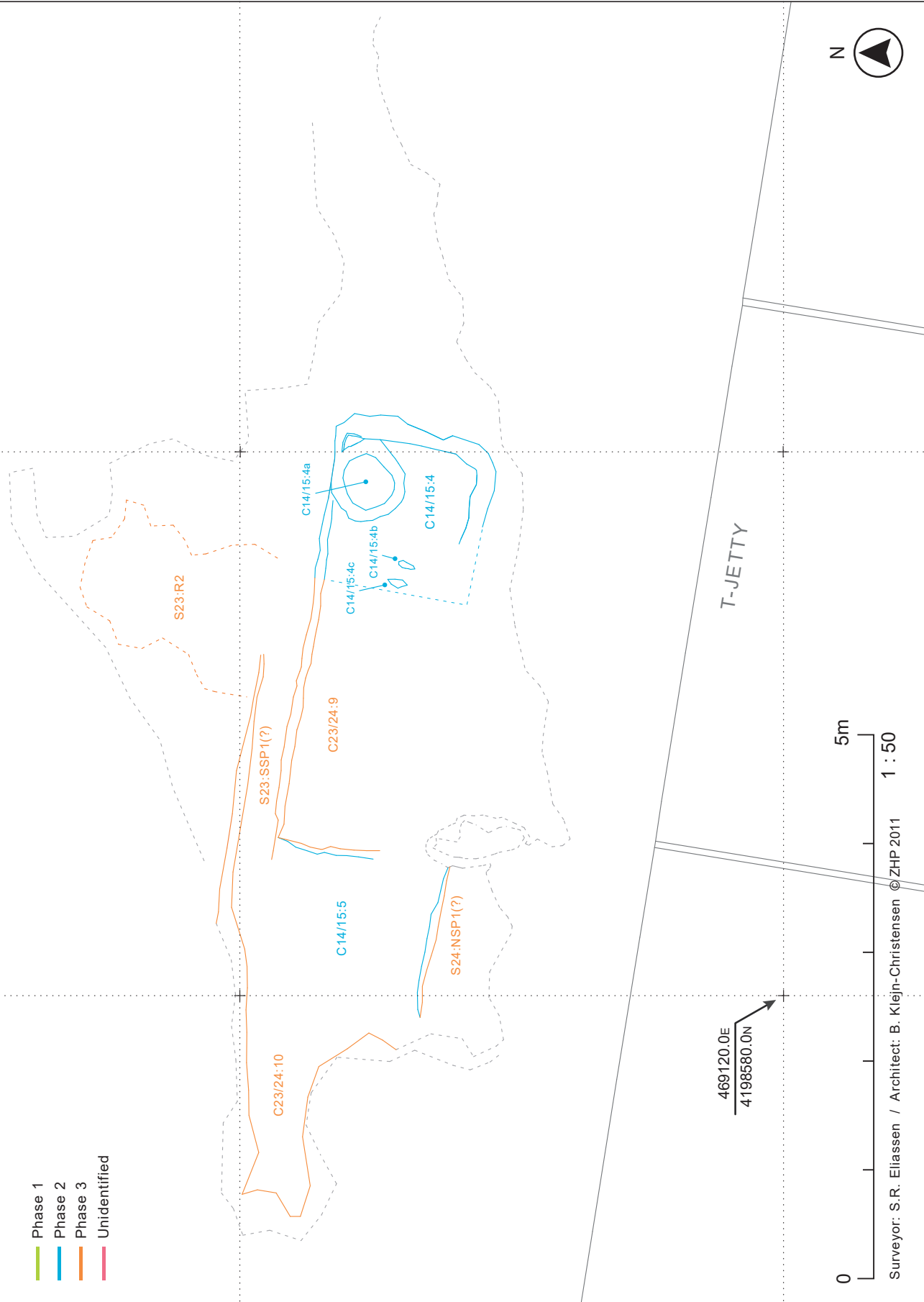

5m

1 : 50

0

Surveyor: S.R. Eliassen / Architect: B. Klein-Christensen ©ZHP 2011

T-JETTY

469120.0E
4198580.0N

Fig. 173 Sector A, Phase 3, Sections: a) 24–27(land), BW:1 and b) 28(land)

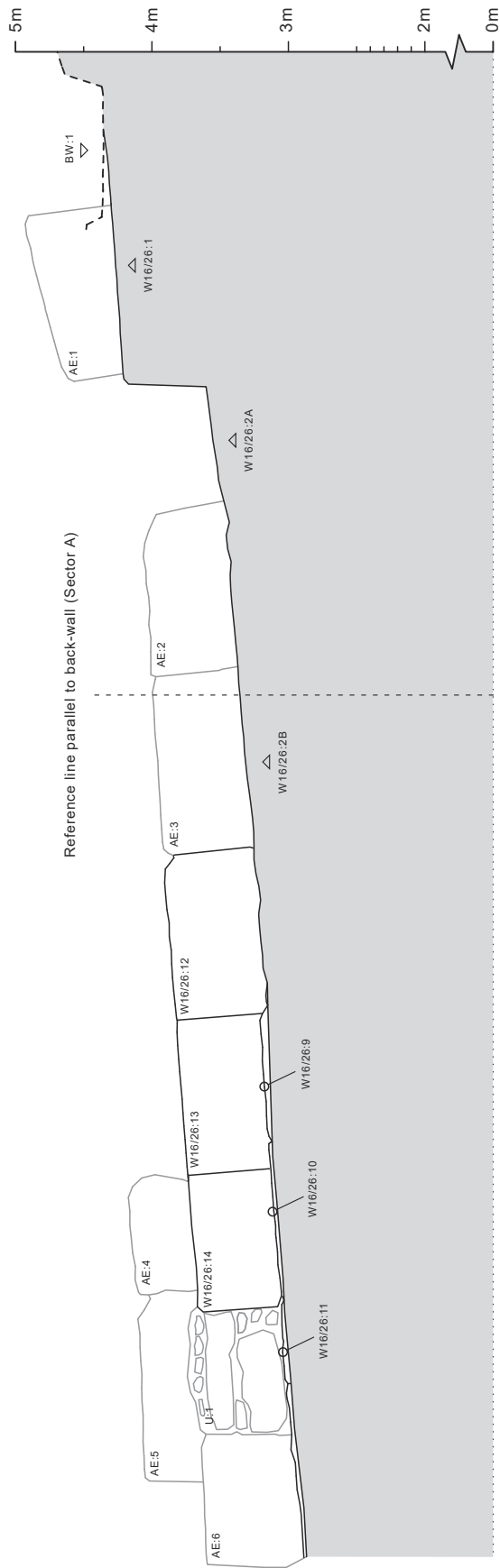

a) Sections 24–27(land), BW:1

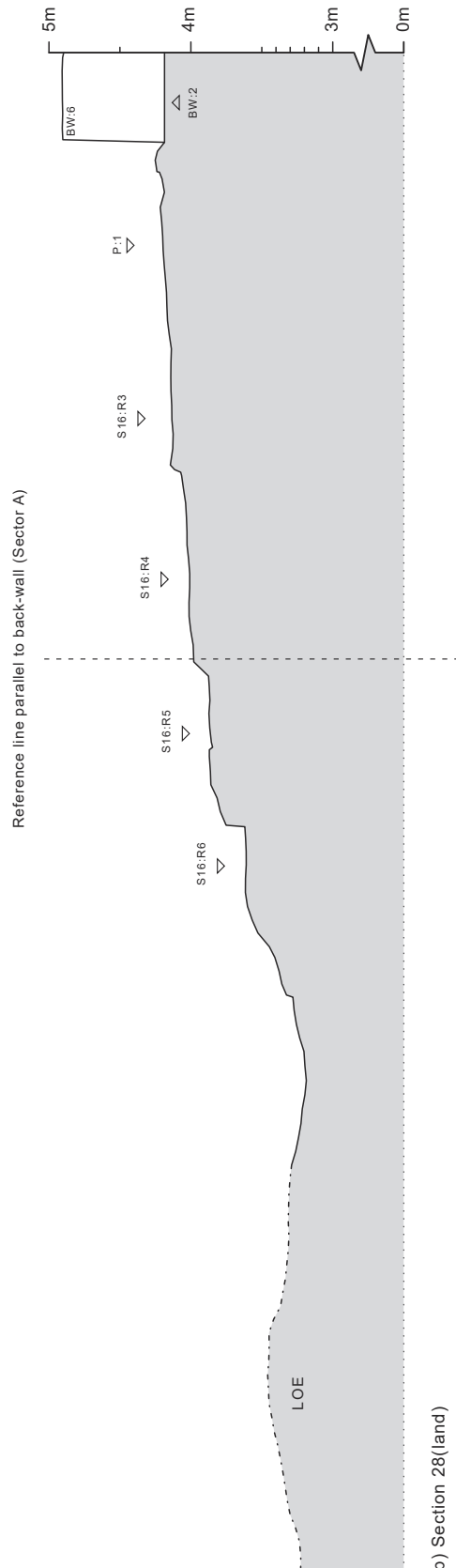

b) Section 28(land)



Surveyor: S.R. Eliassen / Architect: B. Klejn-Christensen © ZHP 2011 1 : 50

Fig. 174 Sector A, Phase 3, Sections: a) 30(land) and b) 31(land)

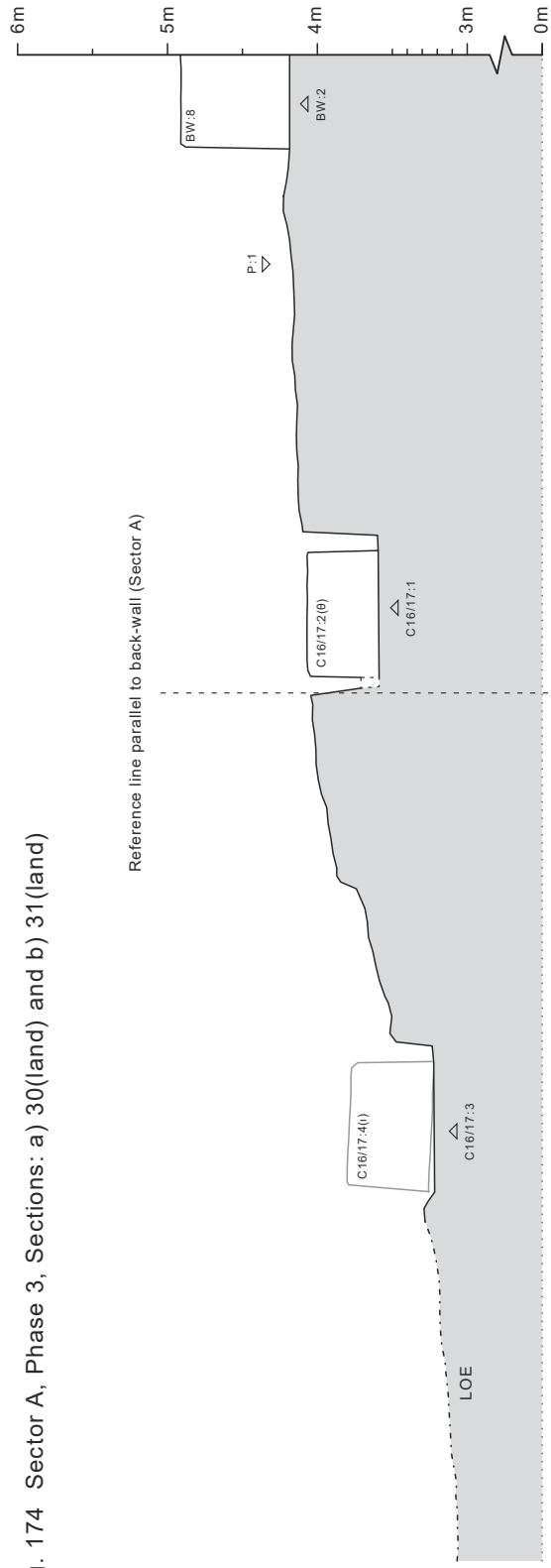

a) Section 30(land)

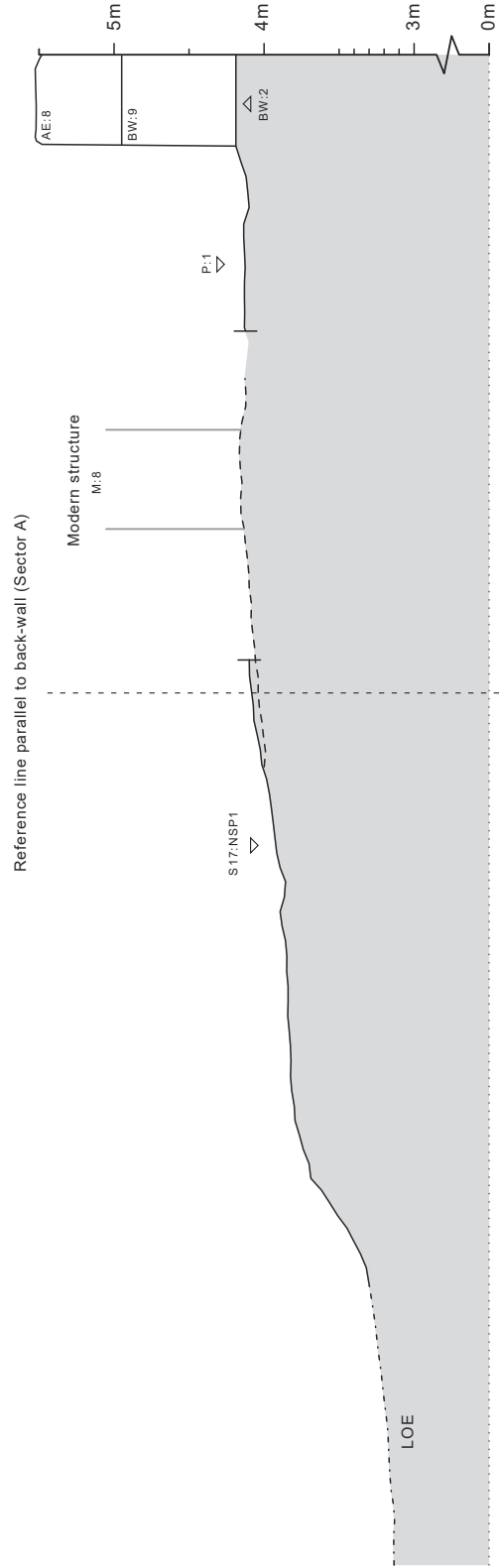

b) Section 31(land), including off-set Section 31a (dashed line)



Surveyor: S.R. Eliassen / Architect: B. Klejn-Christensen © ZHP 2011 1 : 50

Fig. 175 Sector A, Phase 3, Sections: a) 32(land) and b) 33-34(land)

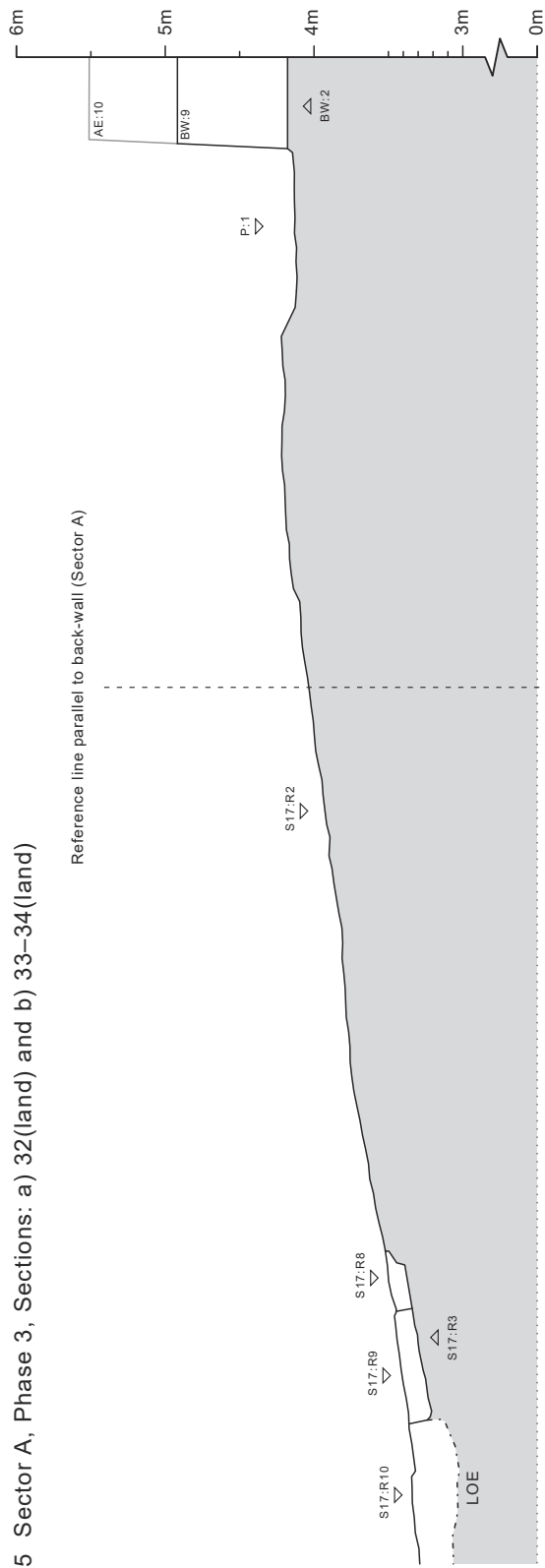

a) Section 32(land)

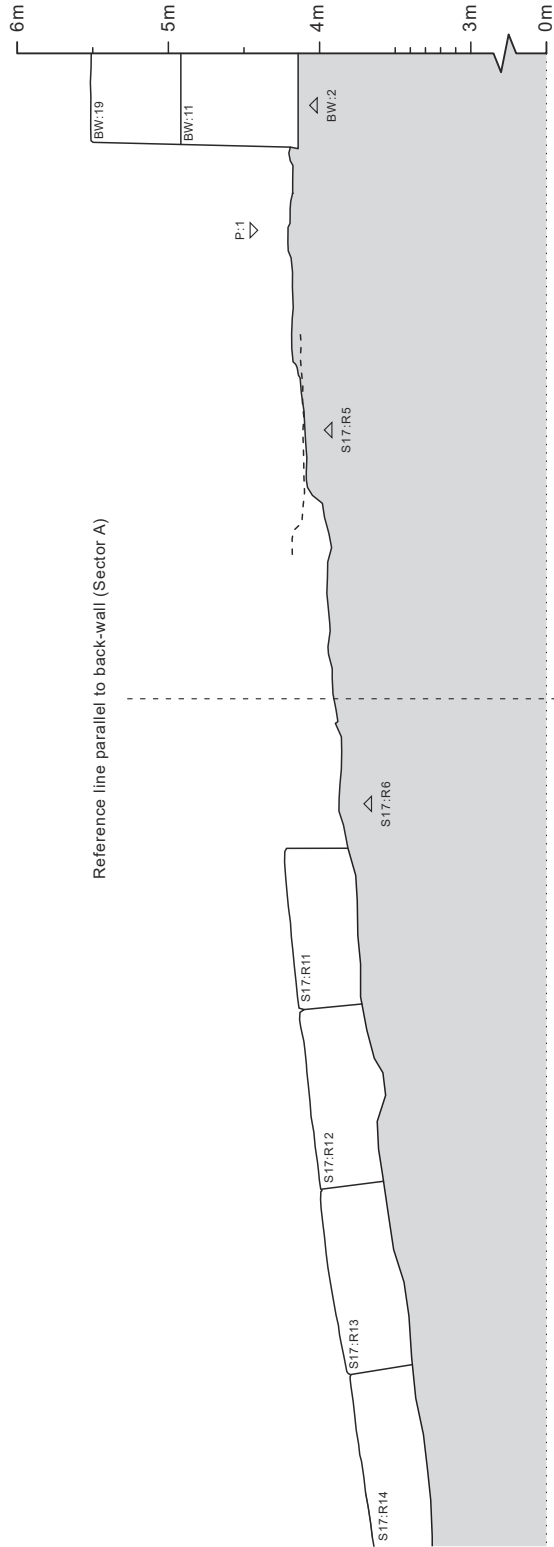

b) Sections 33, 33A, 34(land)



Surveyor: S.R. Eliassen / Architect: B. Klejn-Christensen © ZHP 2011

Fig. 176 Sector A, Phase 3, Sections: a) 35(land) and b) 36(land)

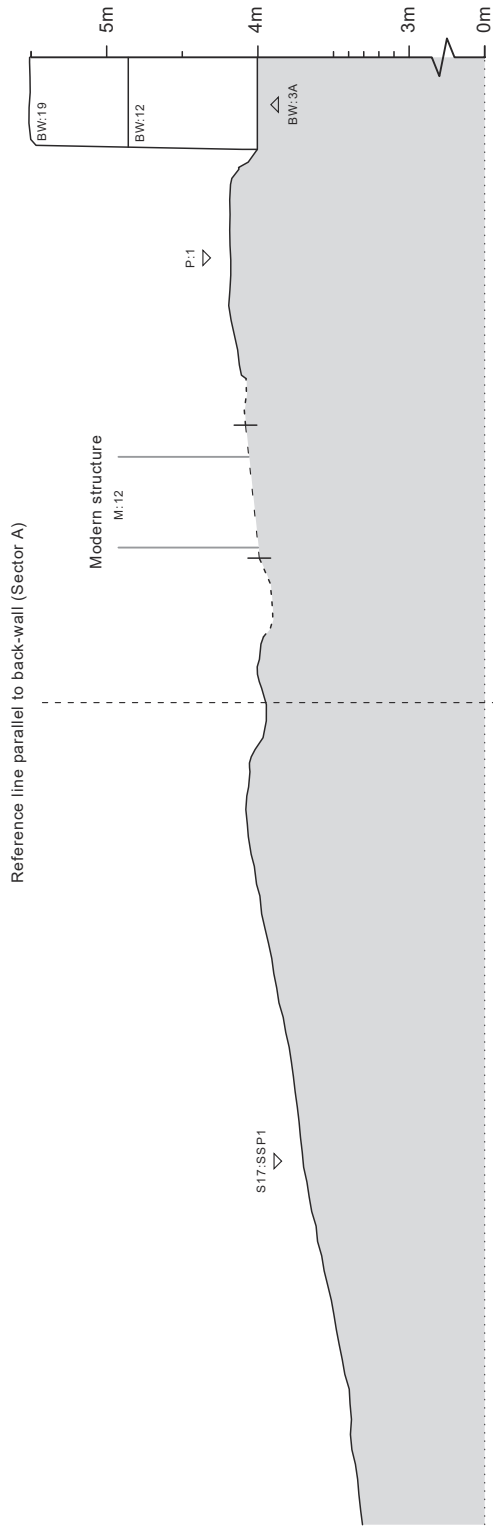

a) Section 35(land)

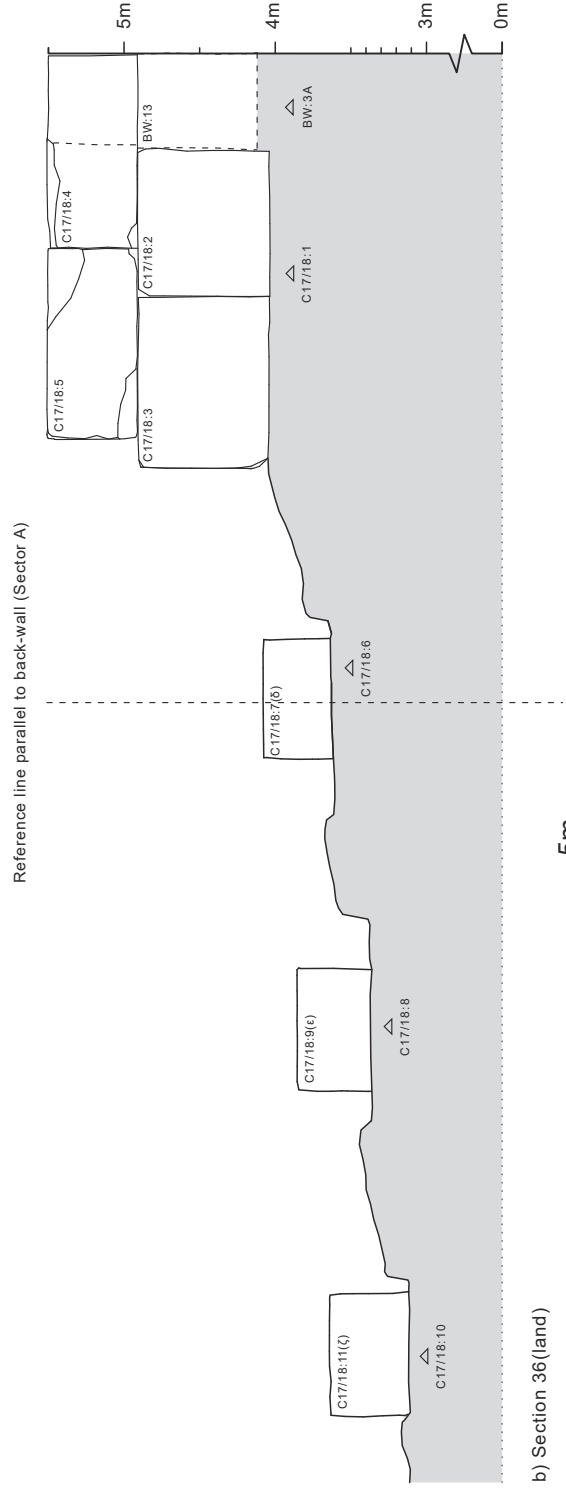

b) Section 36(land)

0 5m

Surveyor: S.R. Eliassen / Architect: B. Klein-Christensen © ZHP 2011 1 : 50

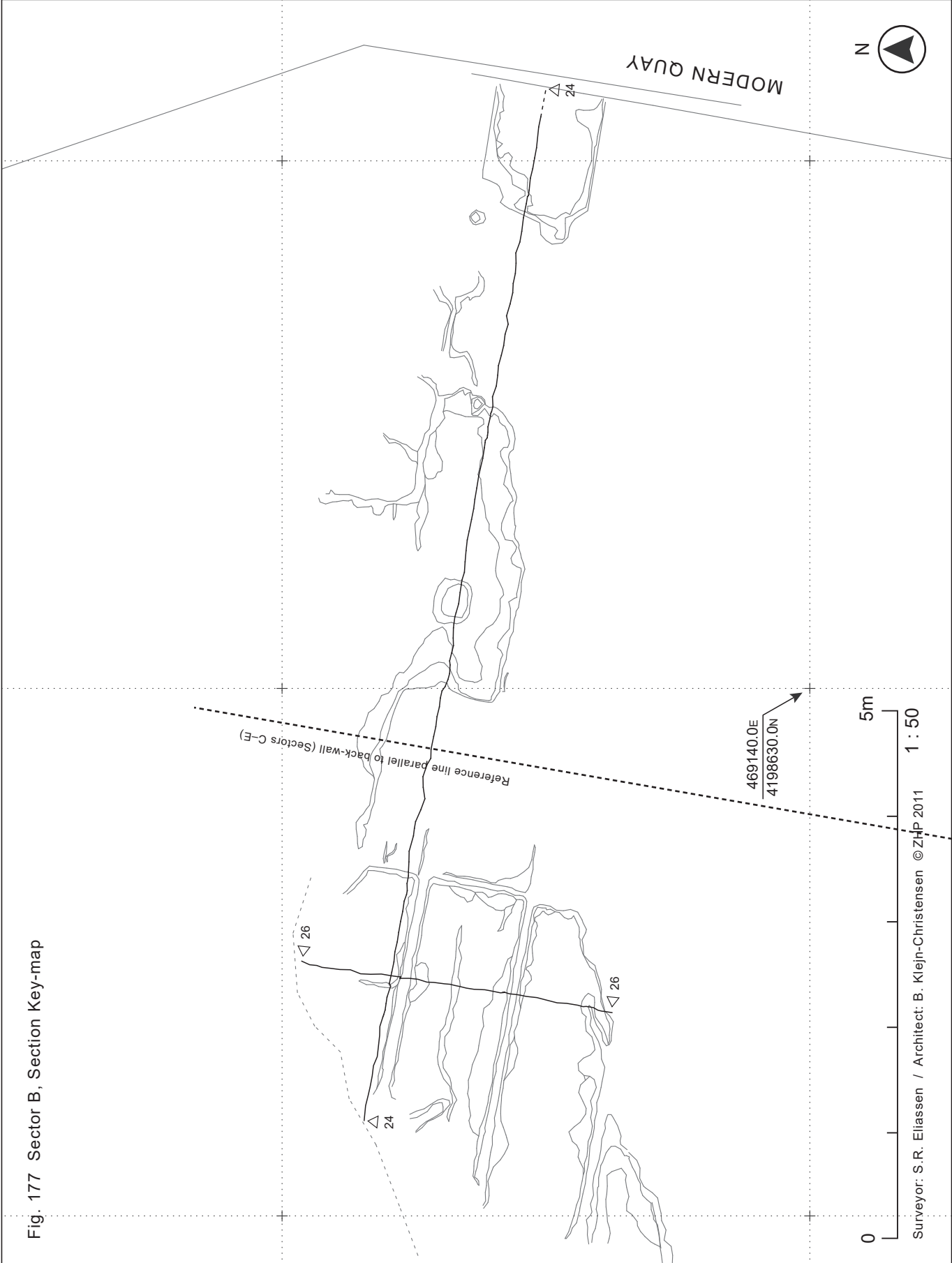
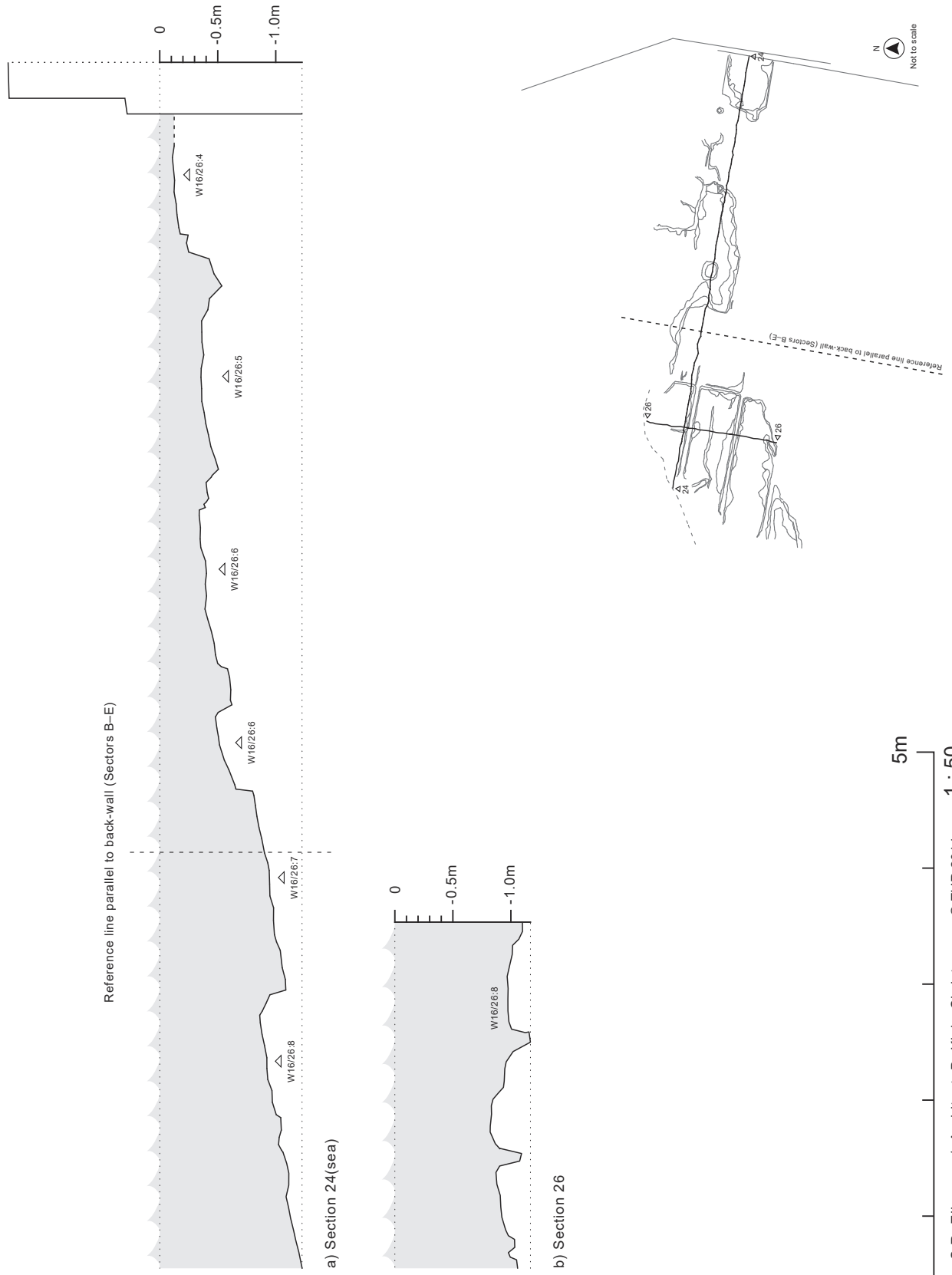

Fig. 177 Sector B, Section Key-map

Fig. 178 Sector B, Sections: a) 24(sea) and b) 26



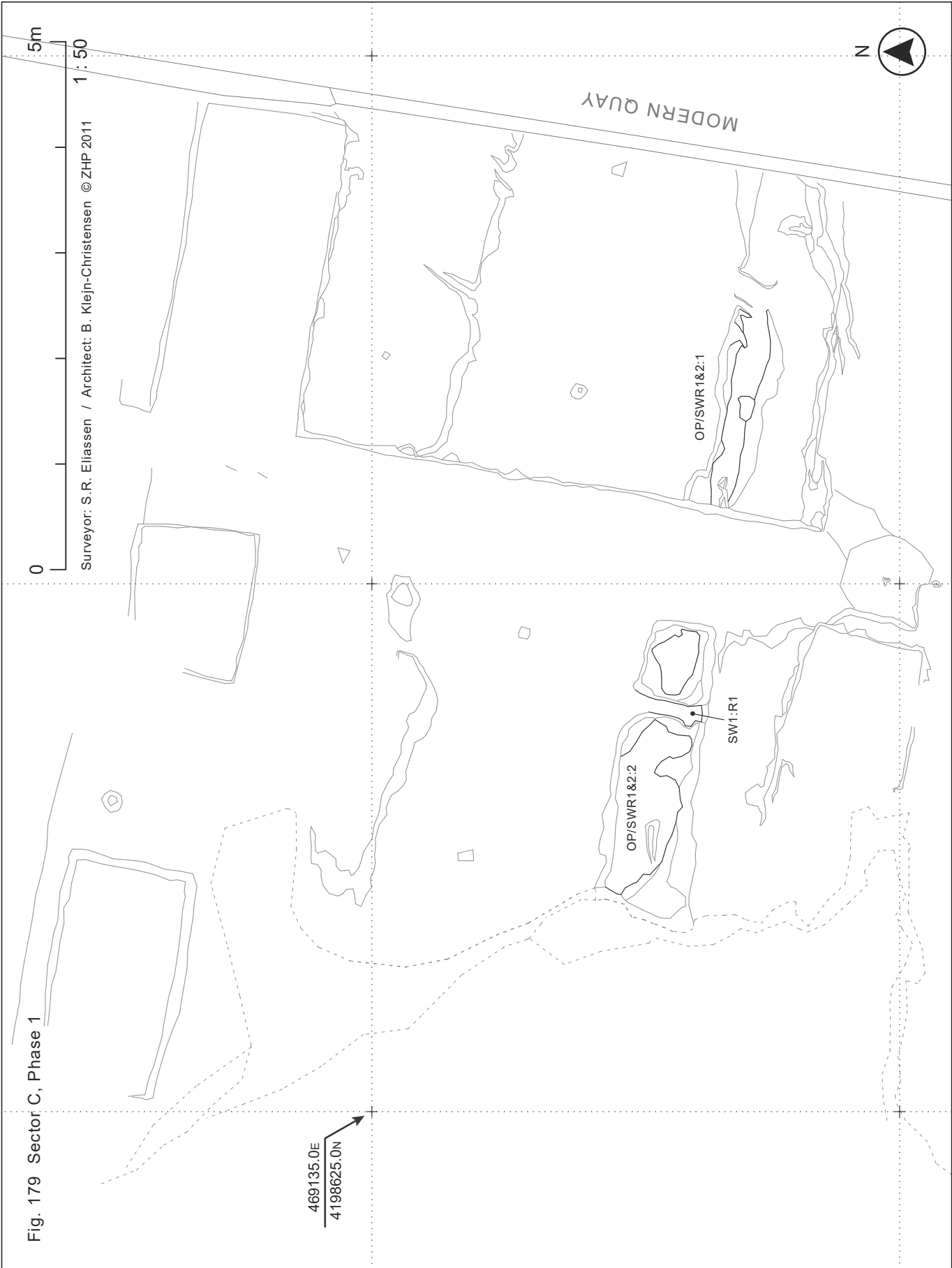

Fig. 179 Sector C, Phase 1





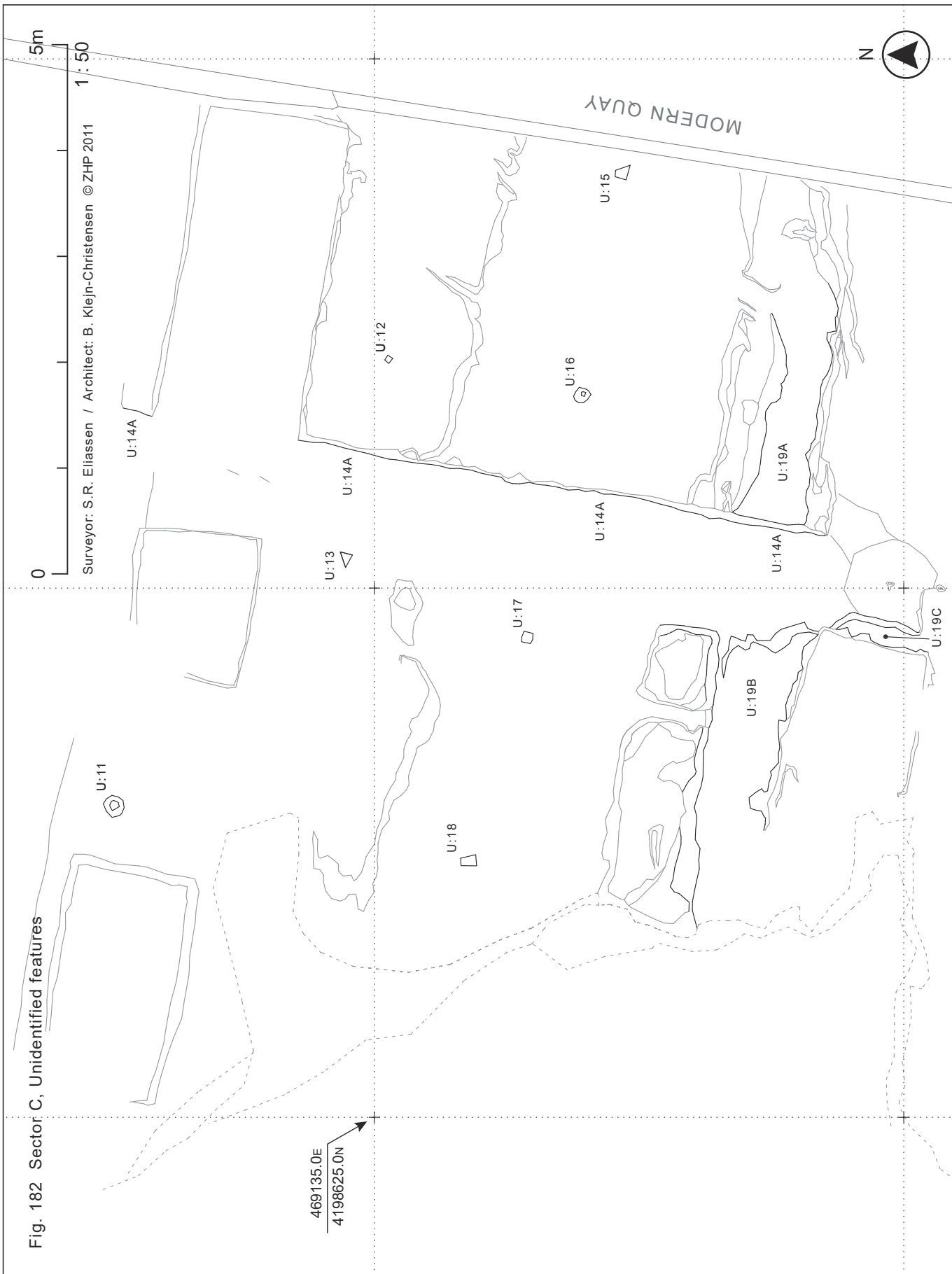

Fig. 182 Sector C, Unidentified features

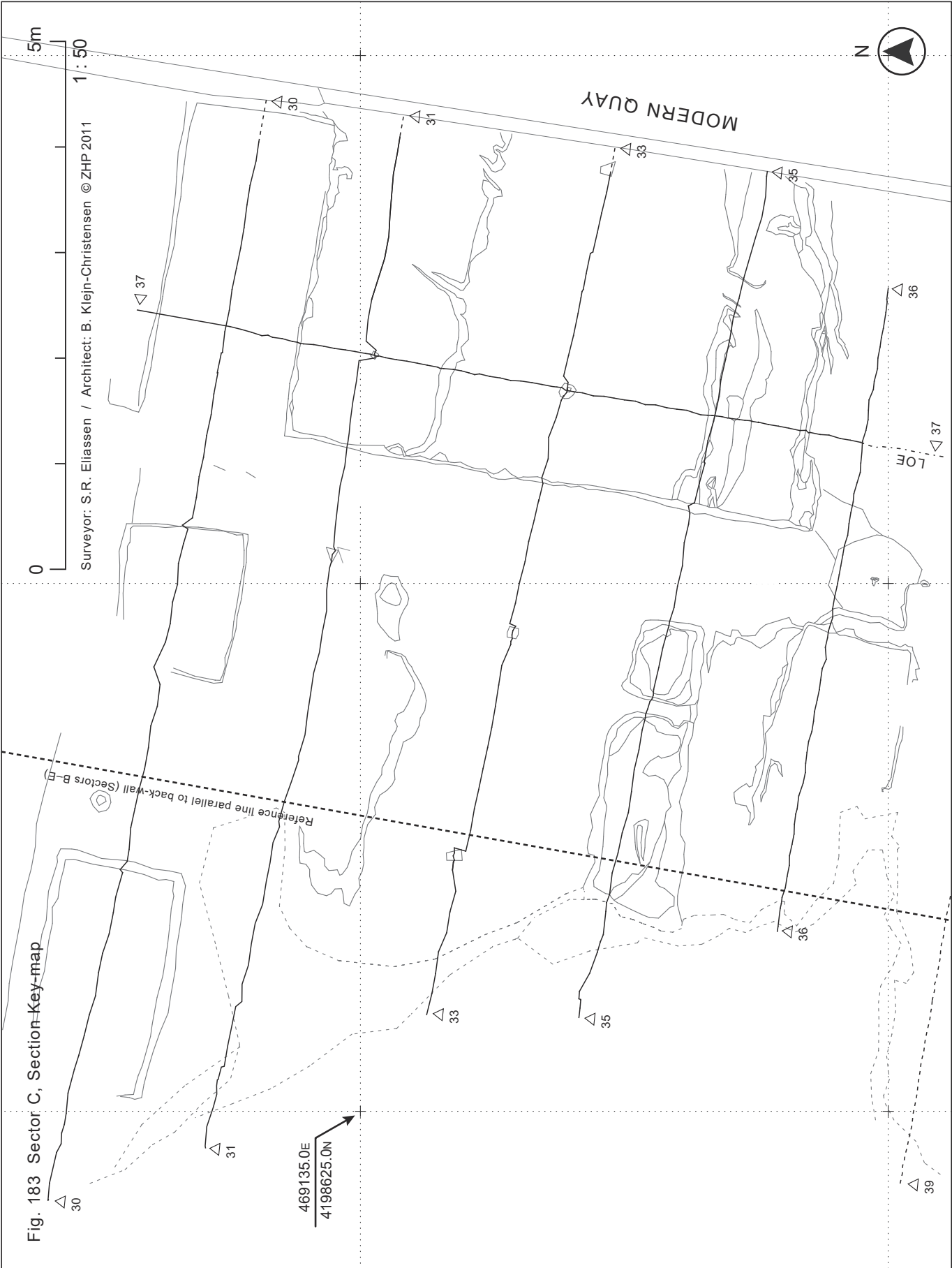
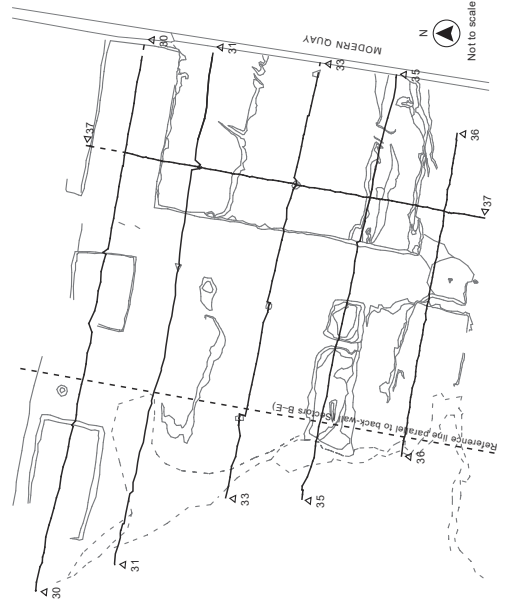
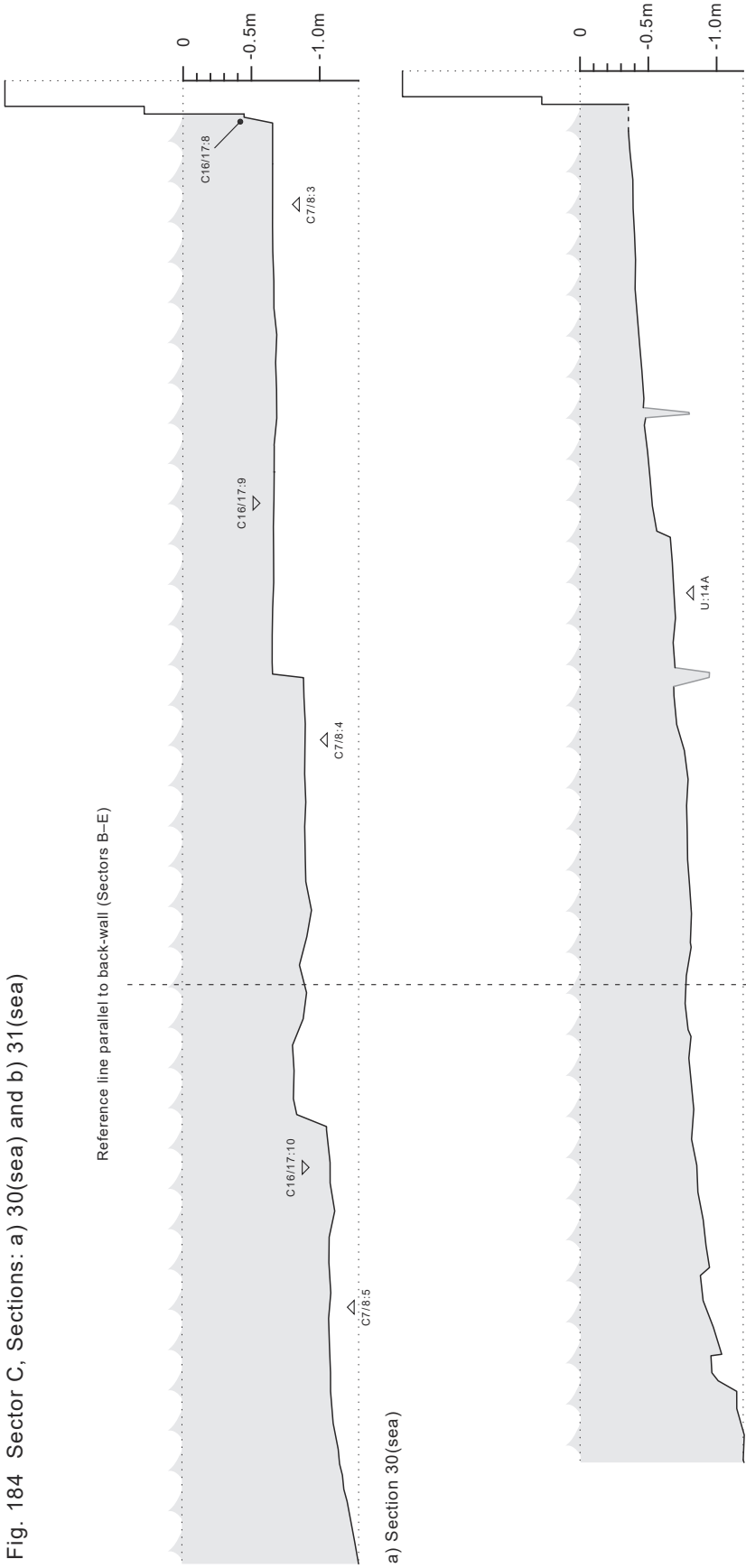

Fig. 183 Sector C, Section-Key-map

Fig. 184 Sector C, Sections: a) 30(sea) and b) 31(sea)



0 5m

Surveyor: S.R. Eliassen / Architect: B. Klejnh-Christensen © ZHP 2011 1 : 50

Fig. 185 Sector C, Sections: a) 33(sea), b) 35(sea), c) 36(sea) and d) 37

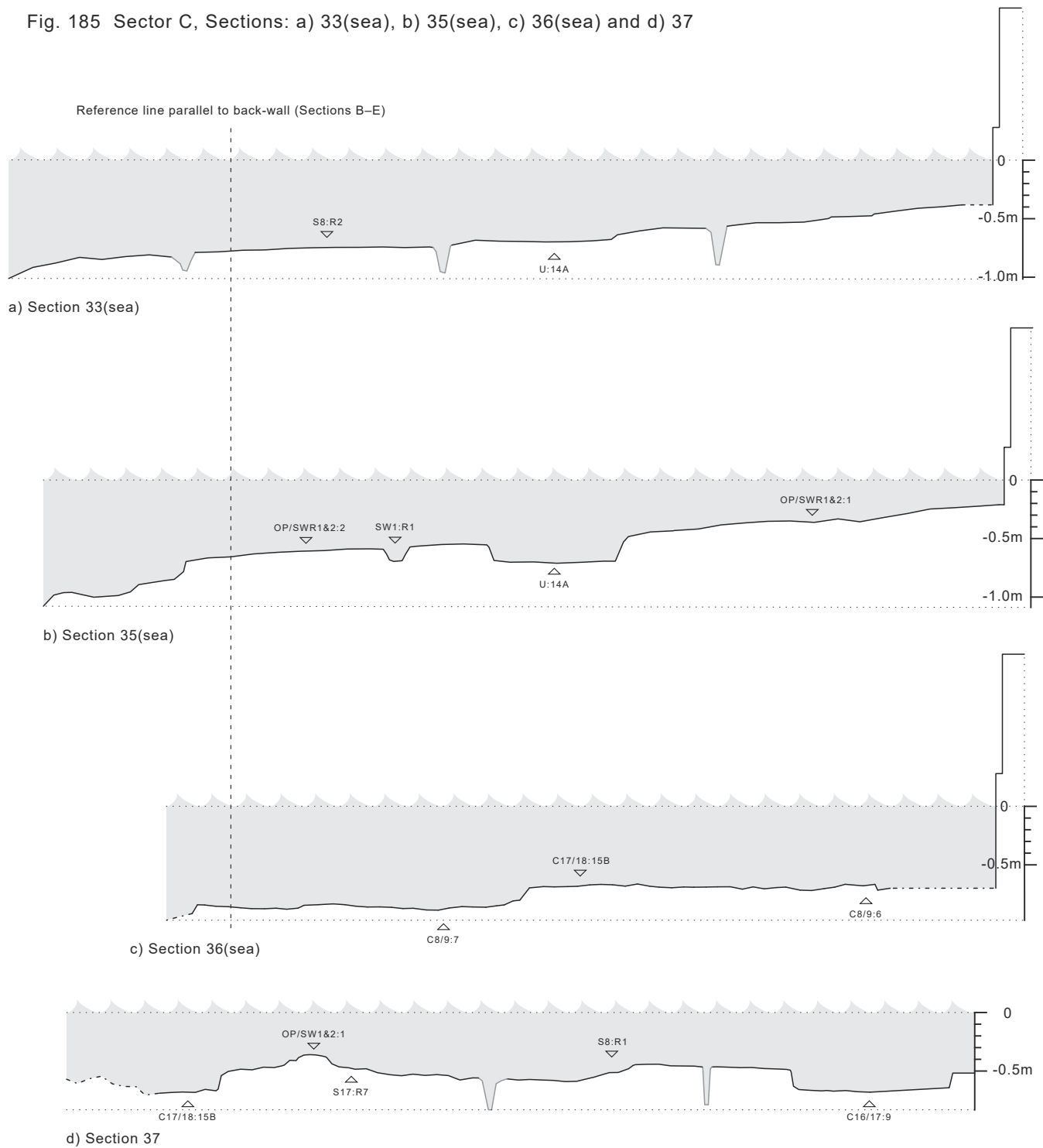

Surveyor: S.R. Eliassen / Architect: B. Klejn-Christensen © ZHP 2011 1 : 50

Fig. 186 Sector D, Phase 1

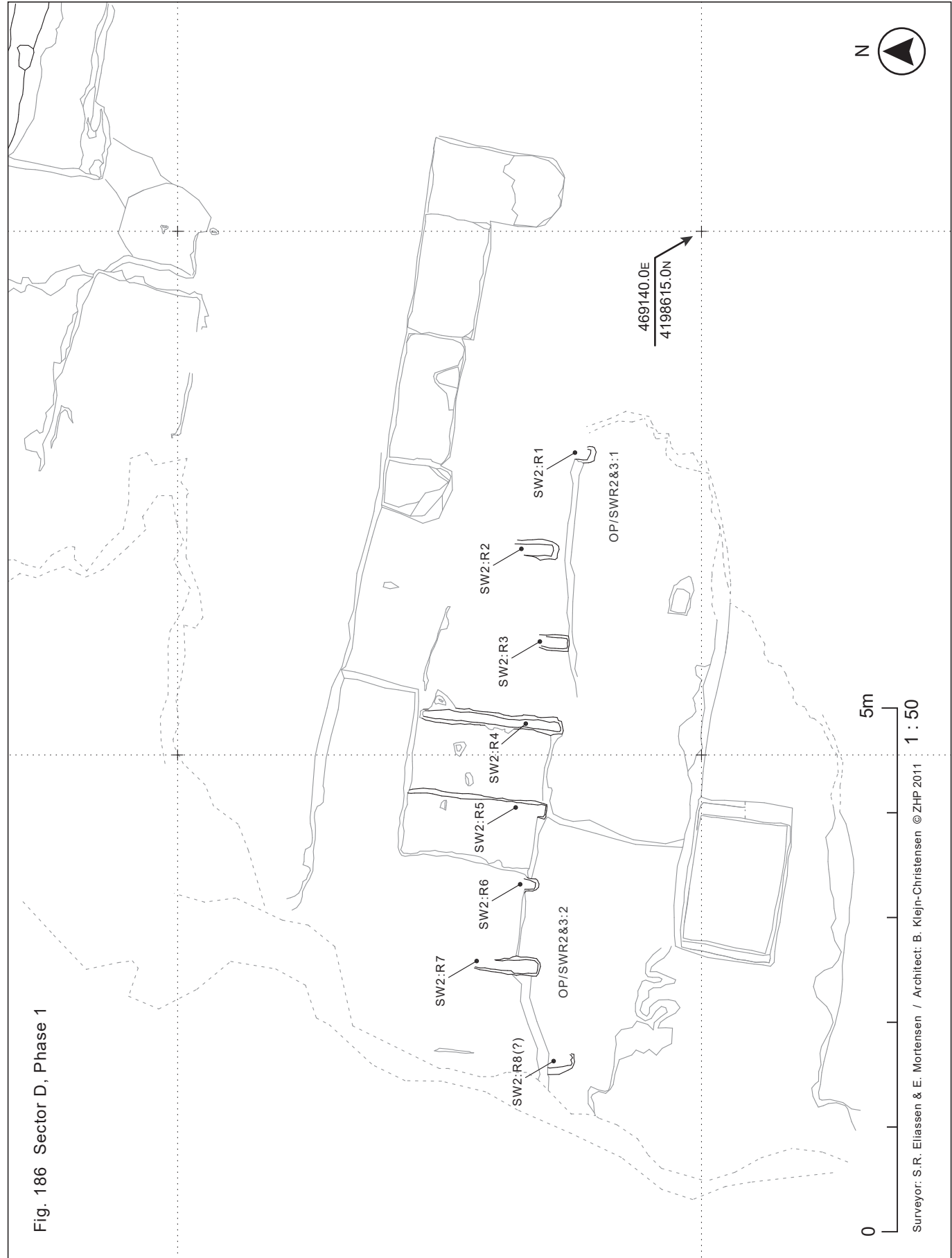

Surveyor: S.R. Eliassen & E. Mortensen / Architect: B. Kleijn-Christensen ©ZHP 2011

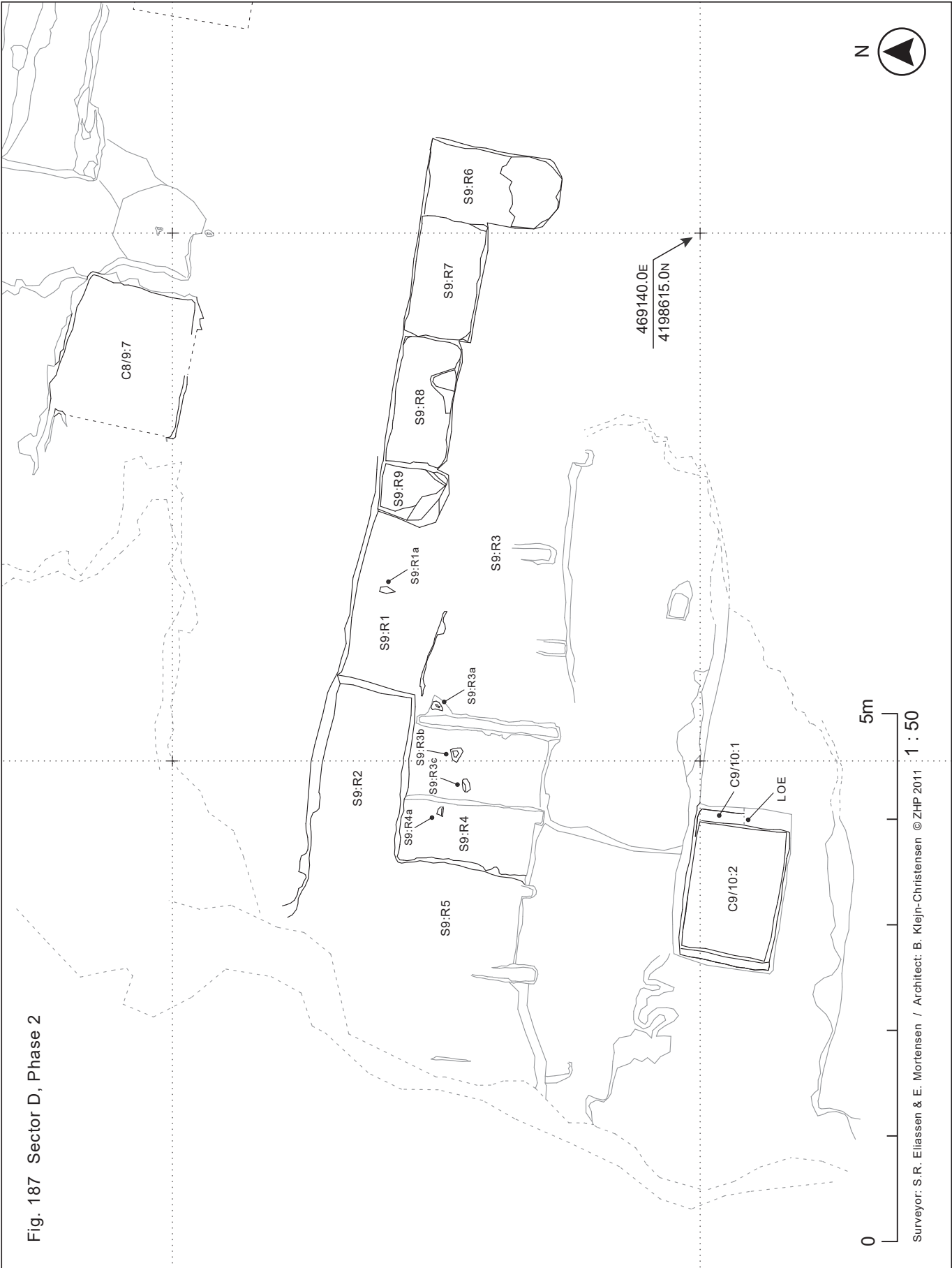
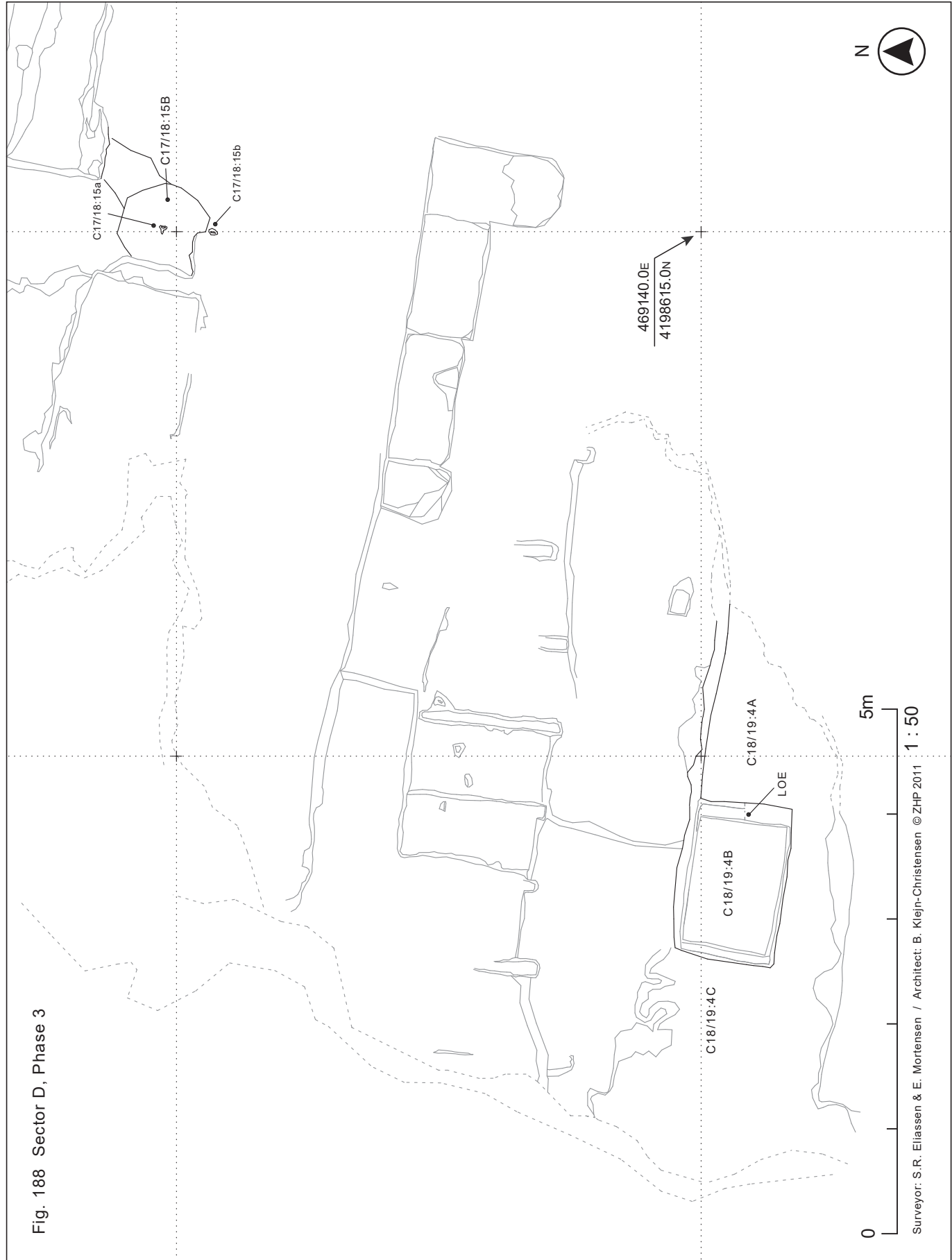

Fig. 187 Sector D, Phase 2

0 5m
 Surveyor: S.R. Eliassen & E. Mortensen / Architect: B. Kleijn-Christensen ©ZHP 2011 1 : 50

Fig. 188 Sector D, Phase 3



0 5m

1 : 50

Surveyor: S.R. Eliassen & E. Mortensen / Architect: B. Kleijn-Christensen ©ZHP 2011

Fig. 189 Sector D, Unidentified features

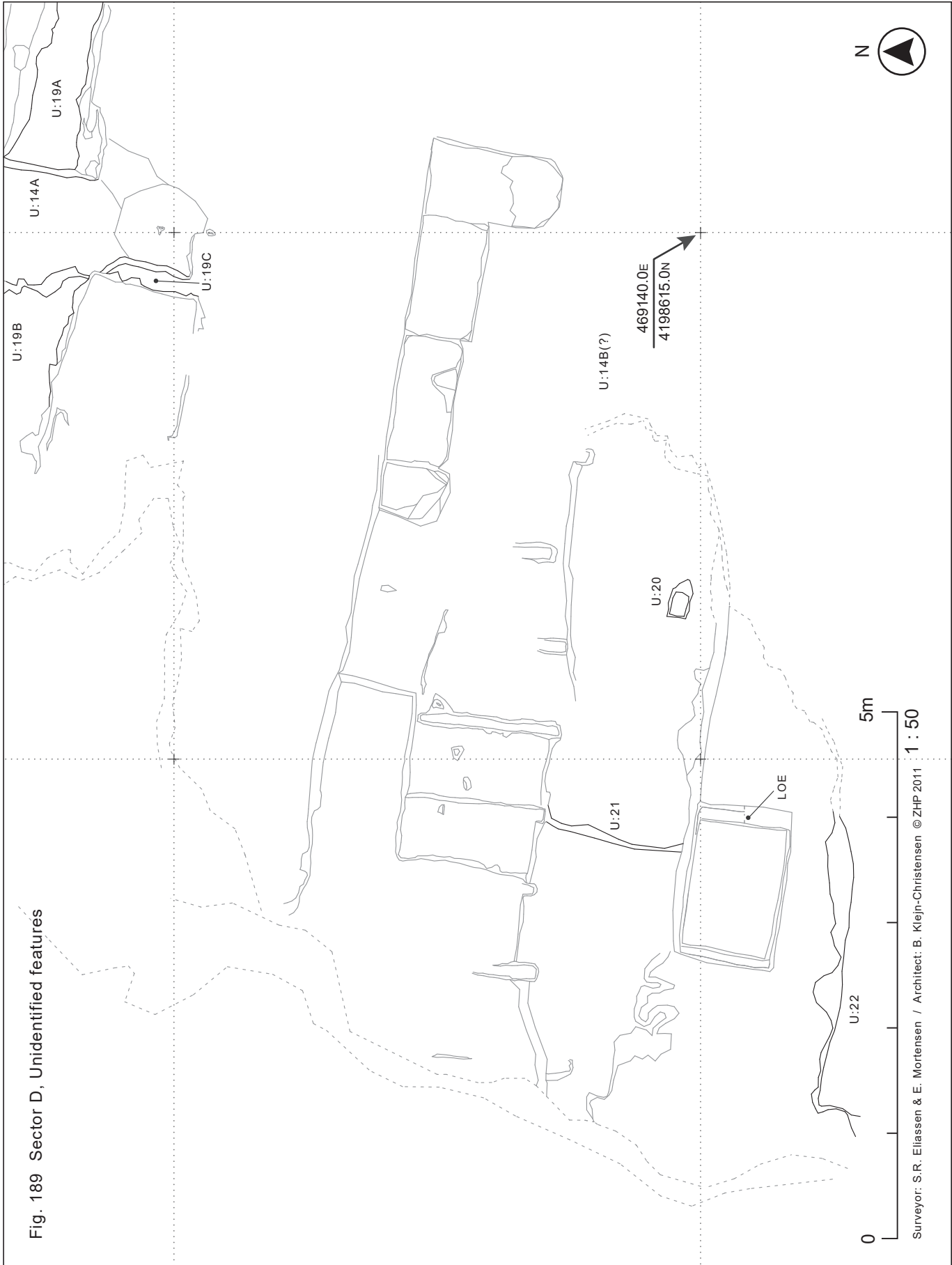

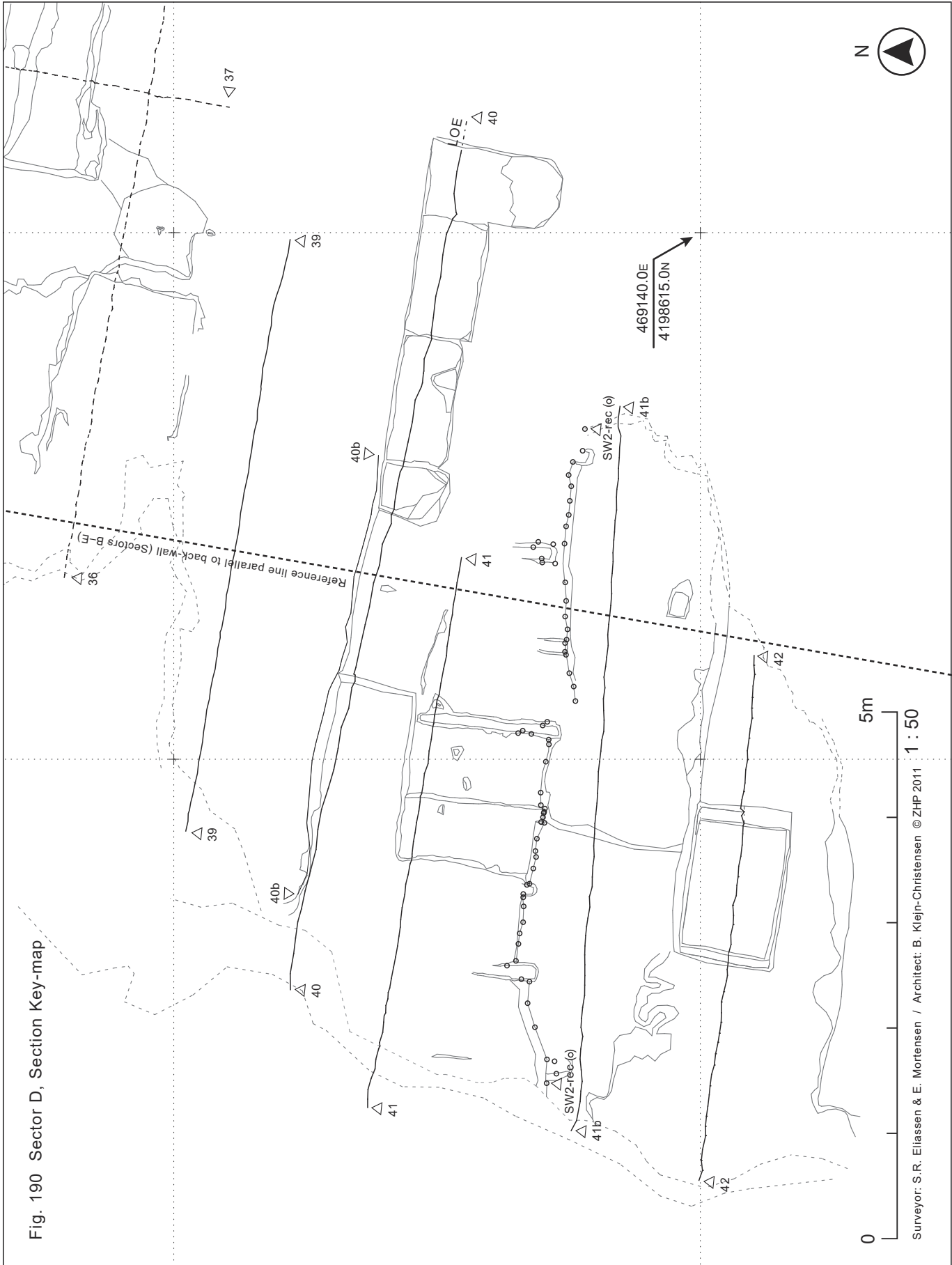
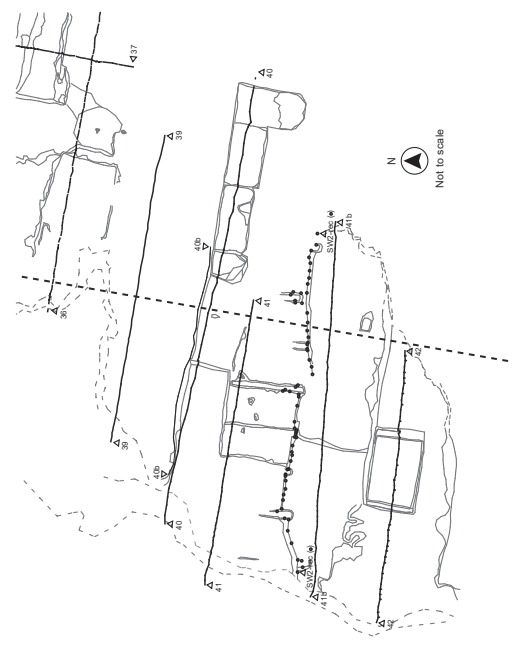
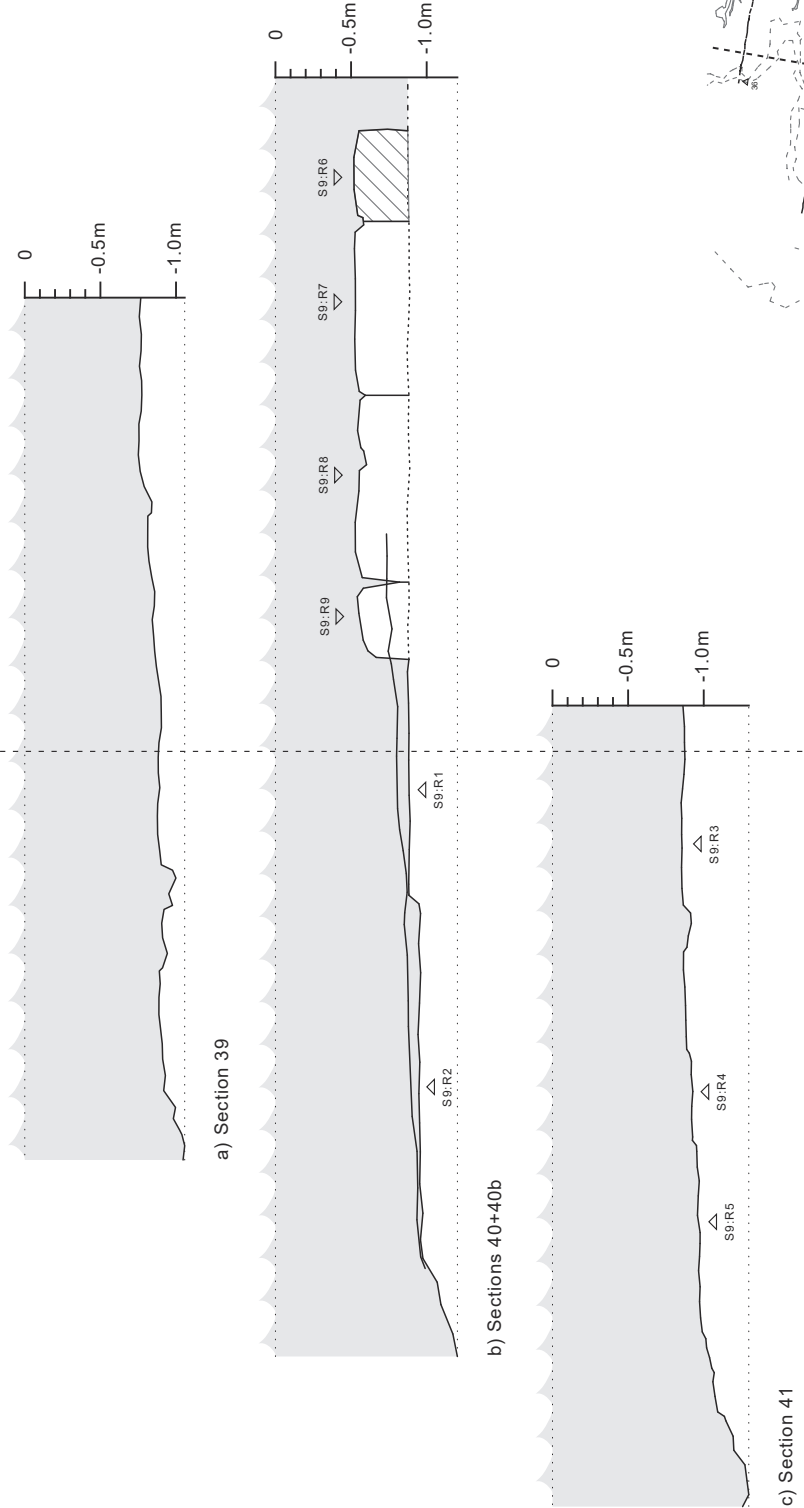

Fig. 191 Sector D, Sections: a) 39, b) 40+40b and c) 41

Reference line parallel to back-wall (Sectors B-E)



Surveyor: S.R. Eliassen / Architect: B. Klejn-Christensen © ZHP 2011 1 : 50

Fig. 192 Sector D, Sections: a) SW2-rec, b) 41b and c) 42

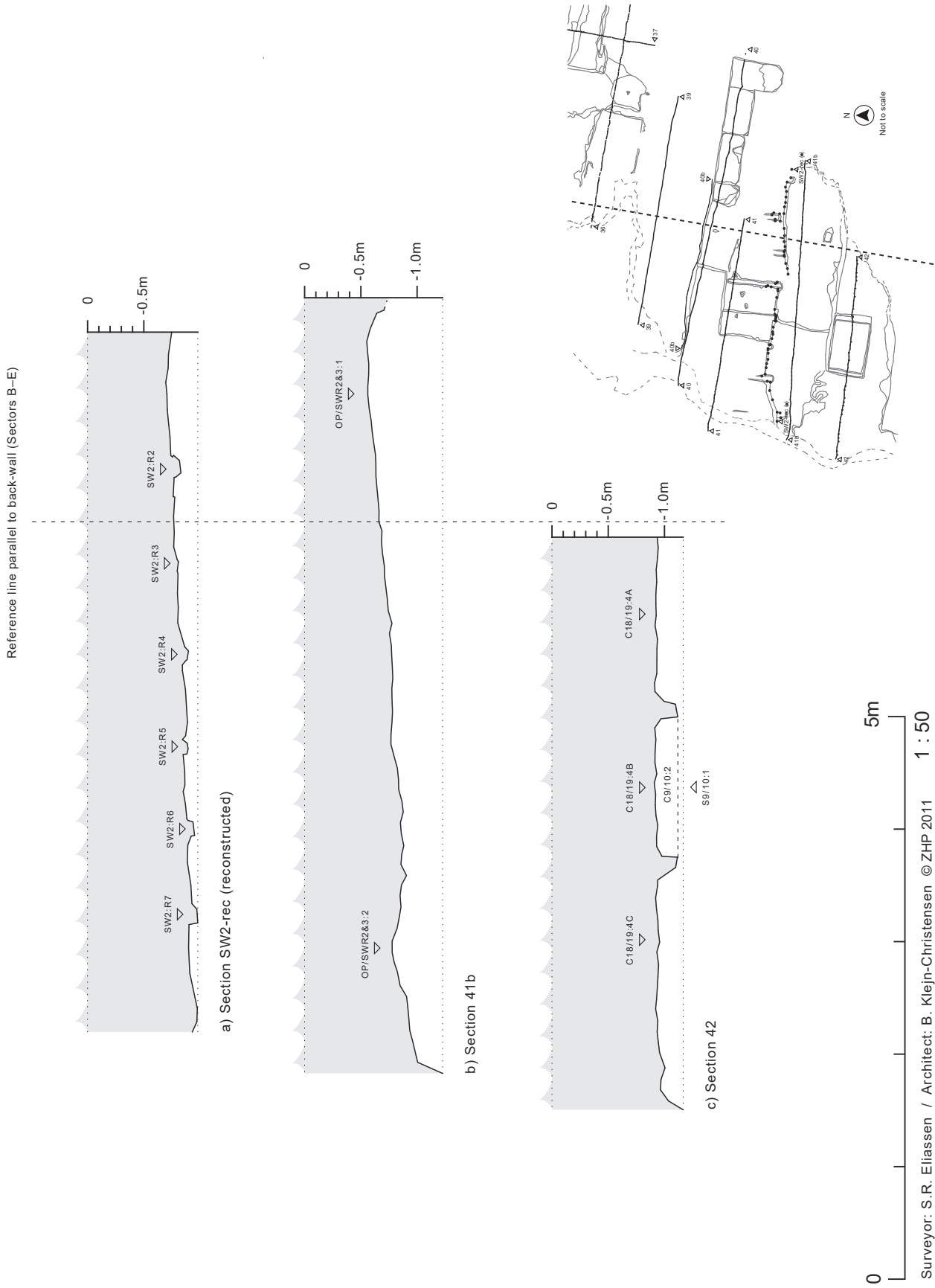

Fig. 193 Sector E, Phase 1

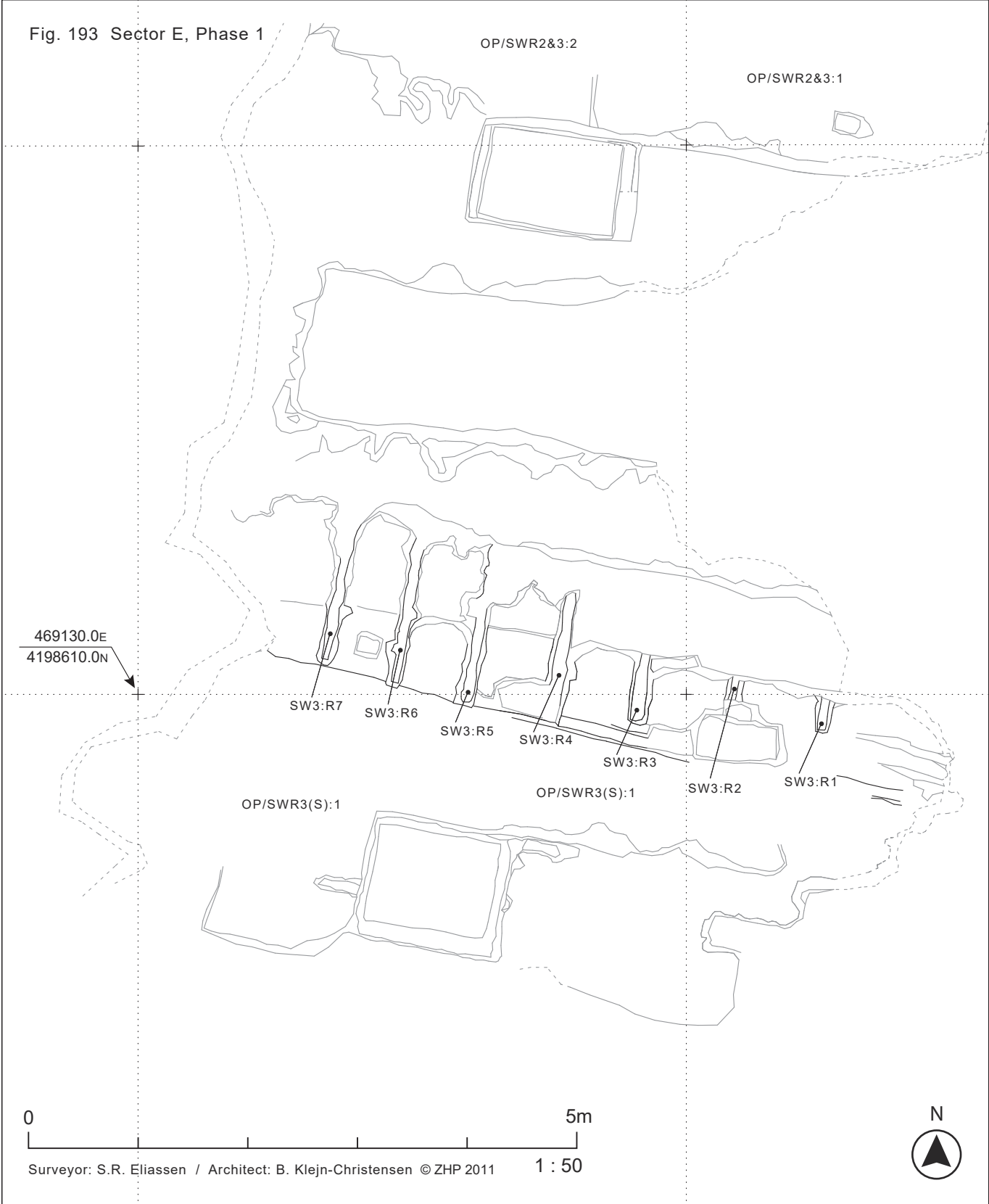

Fig. 194 Sector E, Phase 2



Fig. 195 Sector E, Phase 3



Fig. 196 Sector E, Unidentified features

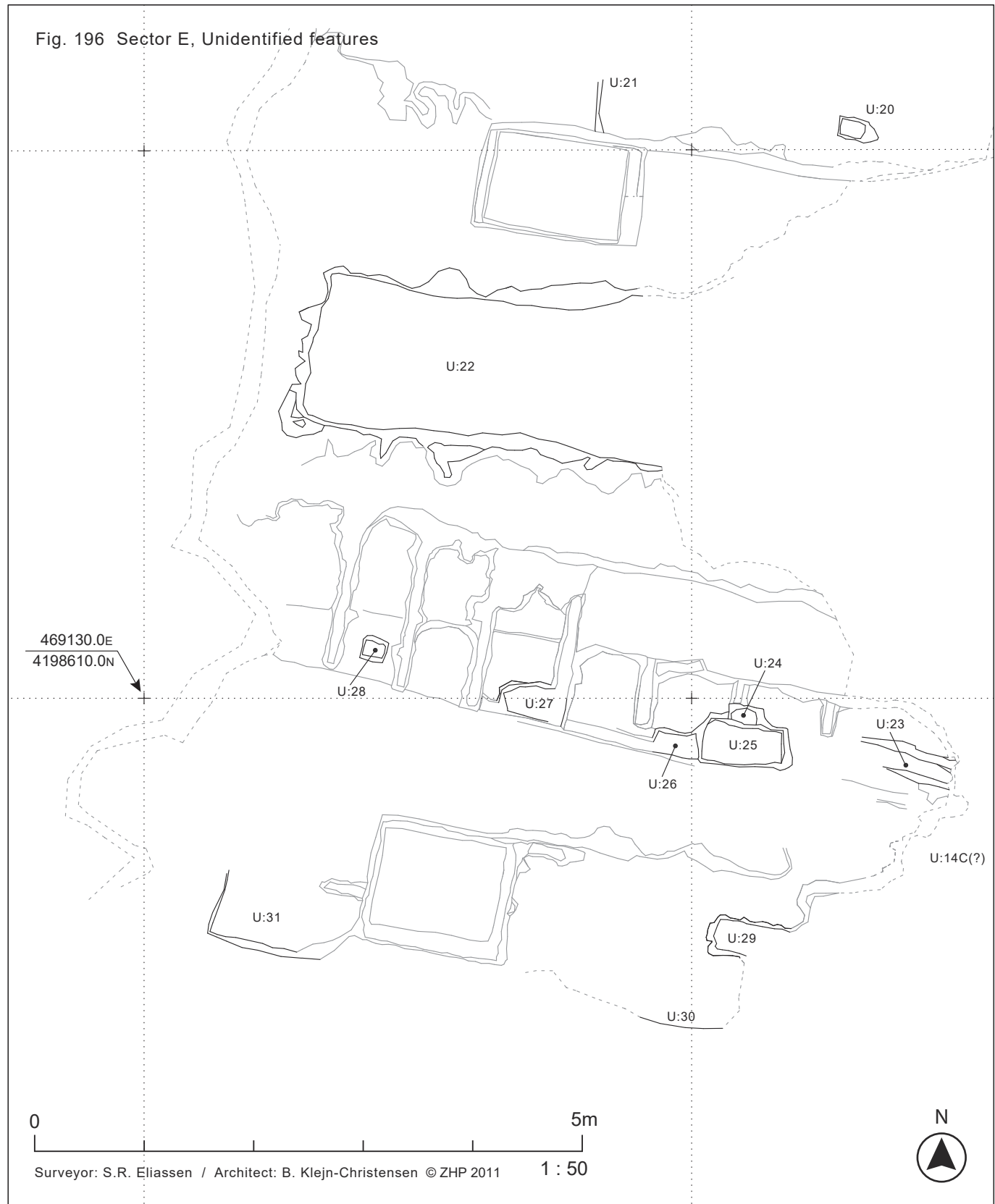

0 5m
Surveyor: S.R. Eliassen / Architect: B. Klejn-Christensen © ZHP 2011 1 : 50



Fig. 197 Sector E, Section Key-map

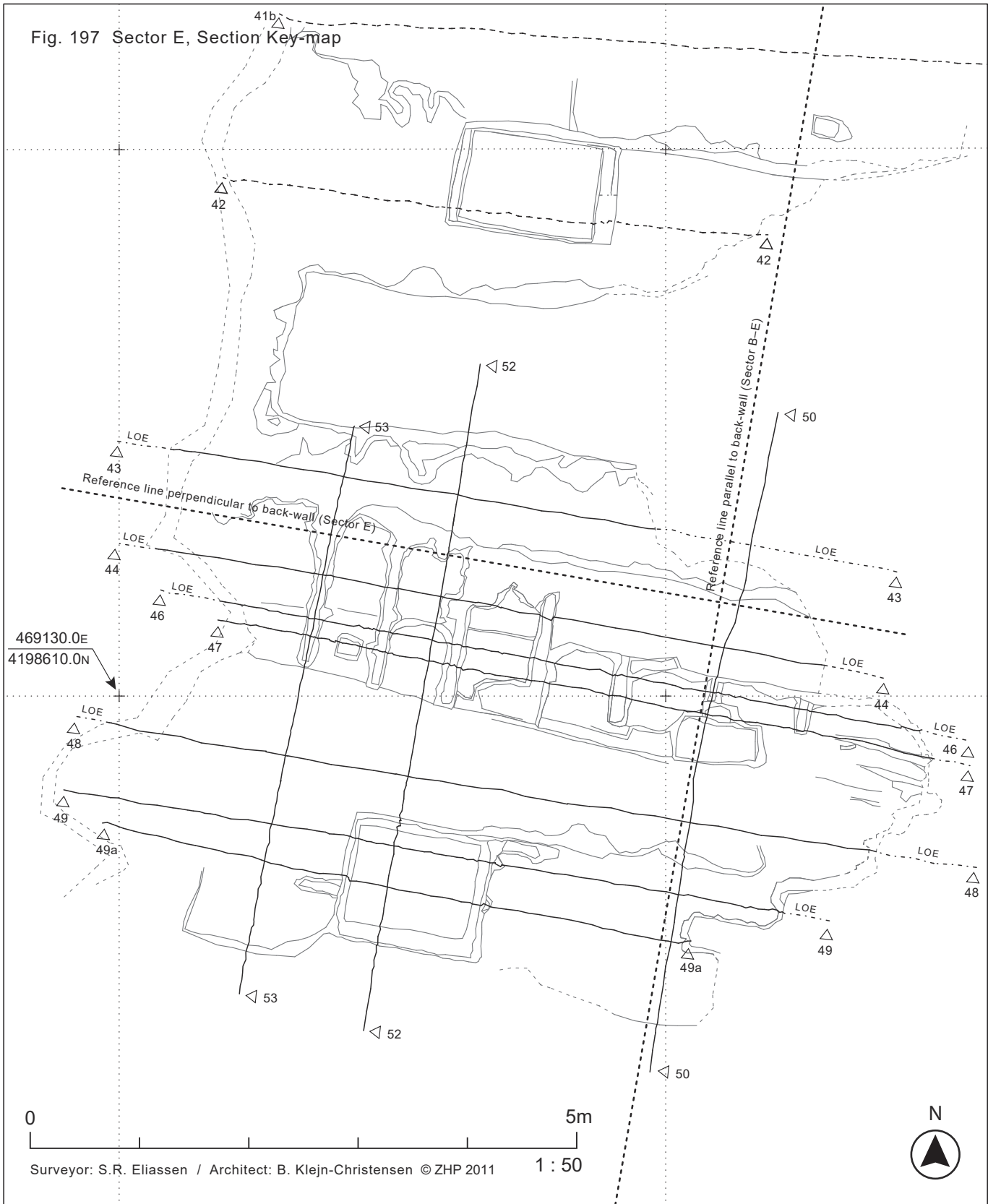
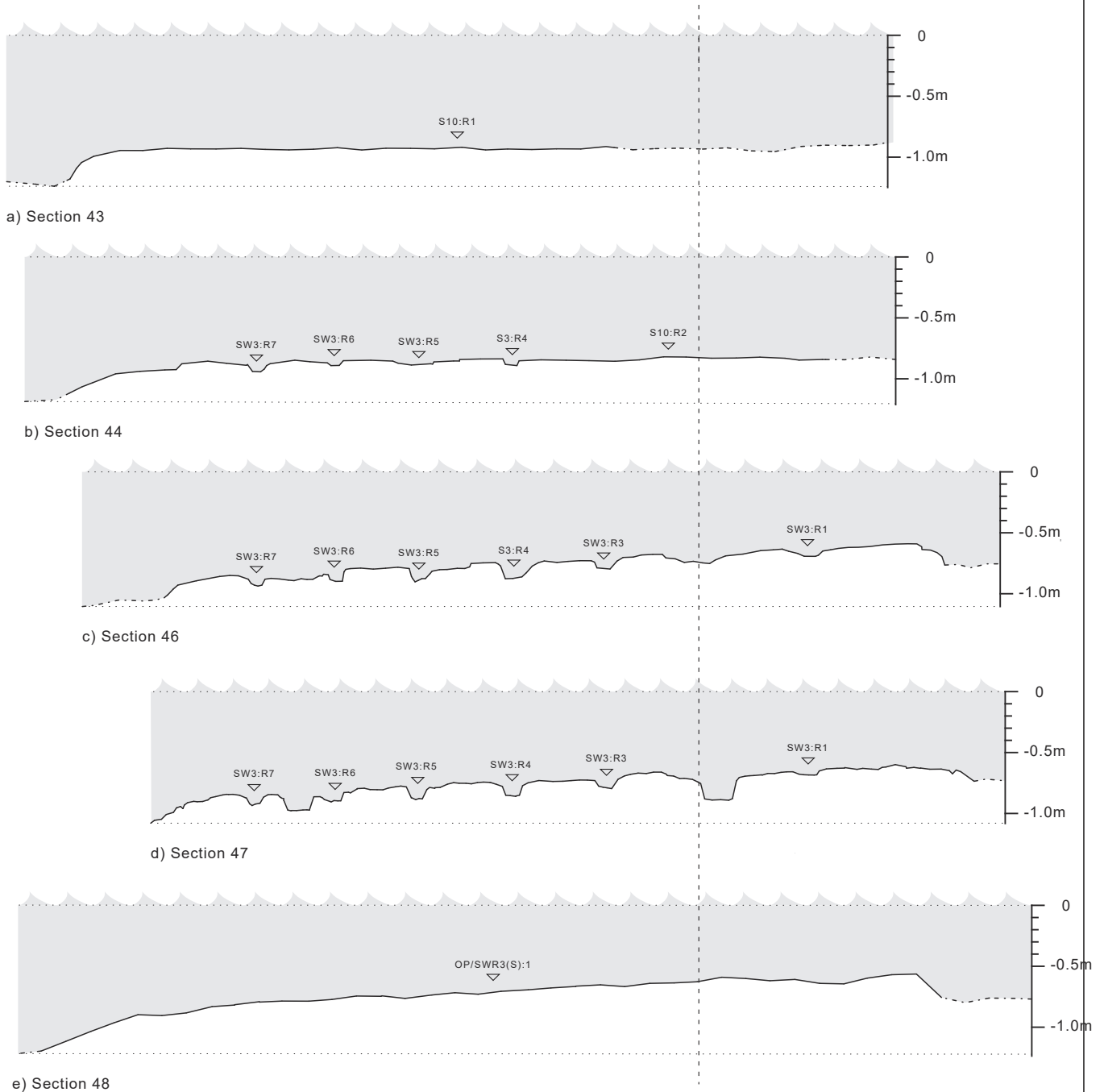

Fig. 198 Sector E, Sections: a) 43, b) 44, c) 46, d) 47 and e) 48

Reference line parallel to back-wall (Sector B-E)



Surveyor: S.R. Eliassen / Architect: B. Klejn-Christensen © ZHP 2011

1 : 50

Fig. 199 Sector E, Sections: a) 49, b) 49a, c) 50, d) 52 and e) 53

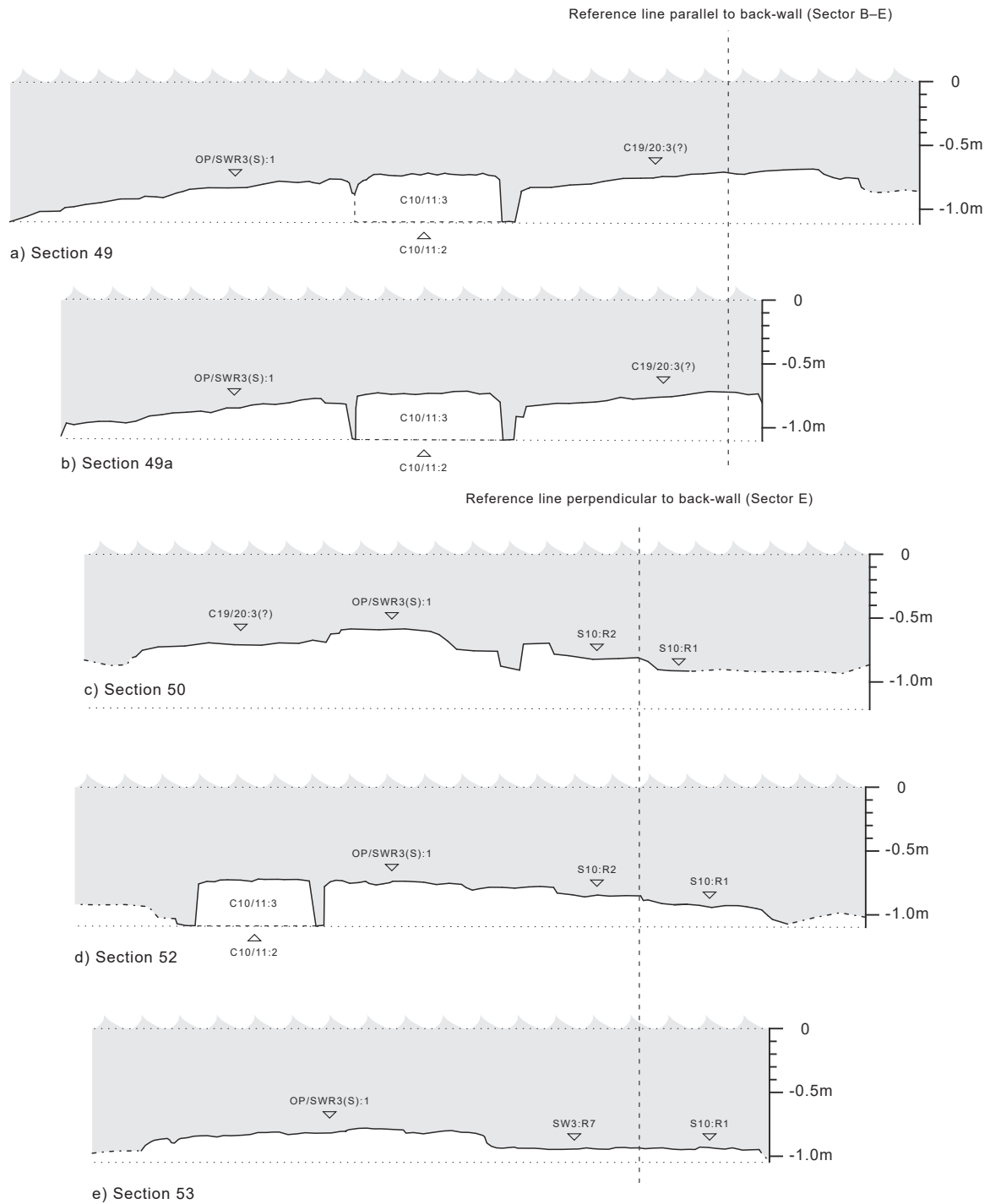

0 5m

Surveyor: S.R. Eliassen / Architect: B. Klejn-Christensen © ZHP 2011 1 : 50

Fig. 200 Sector F, Phase 1

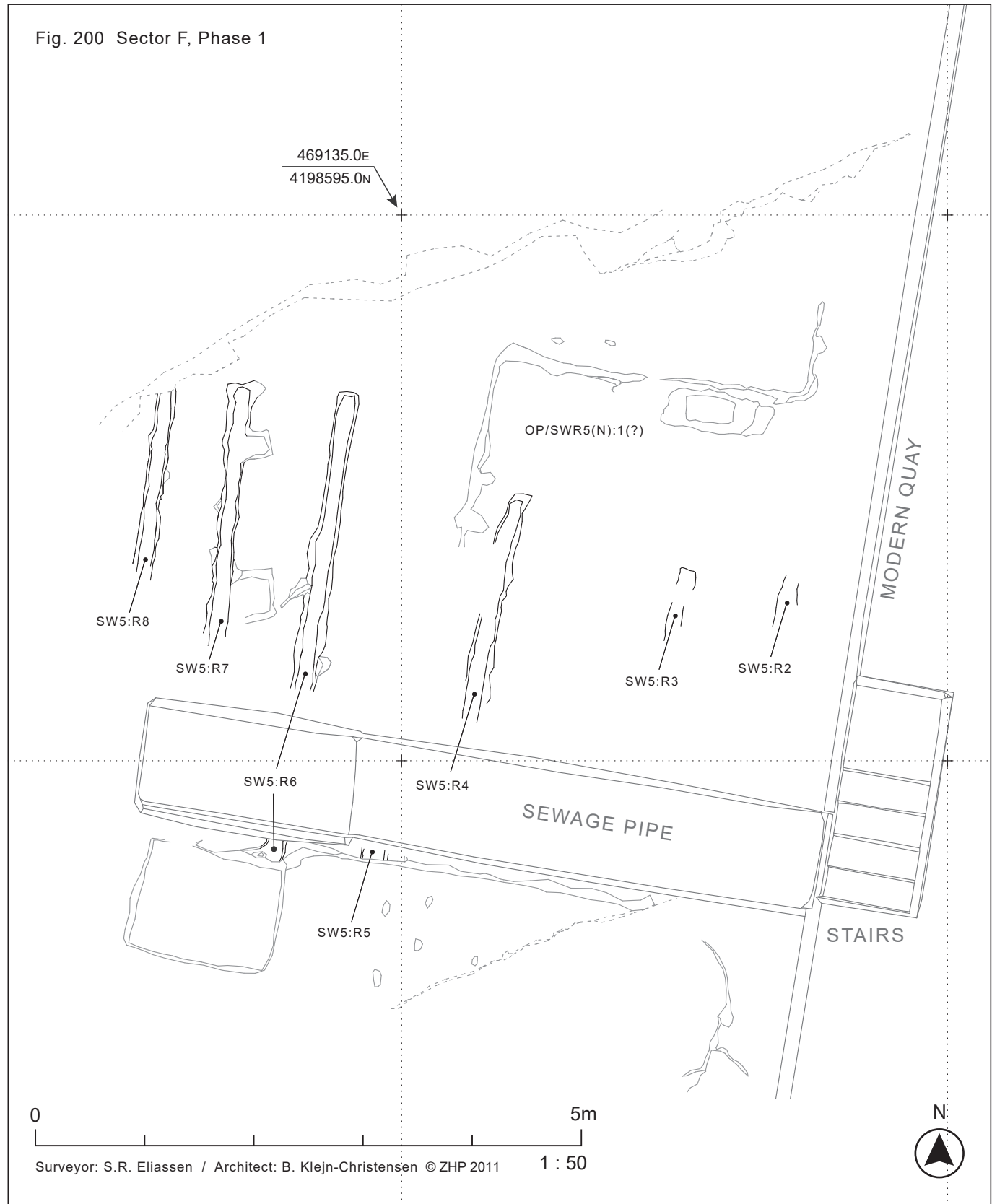

0 5m
Surveyor: S.R. Eliassen / Architect: B. Klejn-Christensen © ZHP 2011 1 : 50



Fig. 201 Sector F, Phase 2

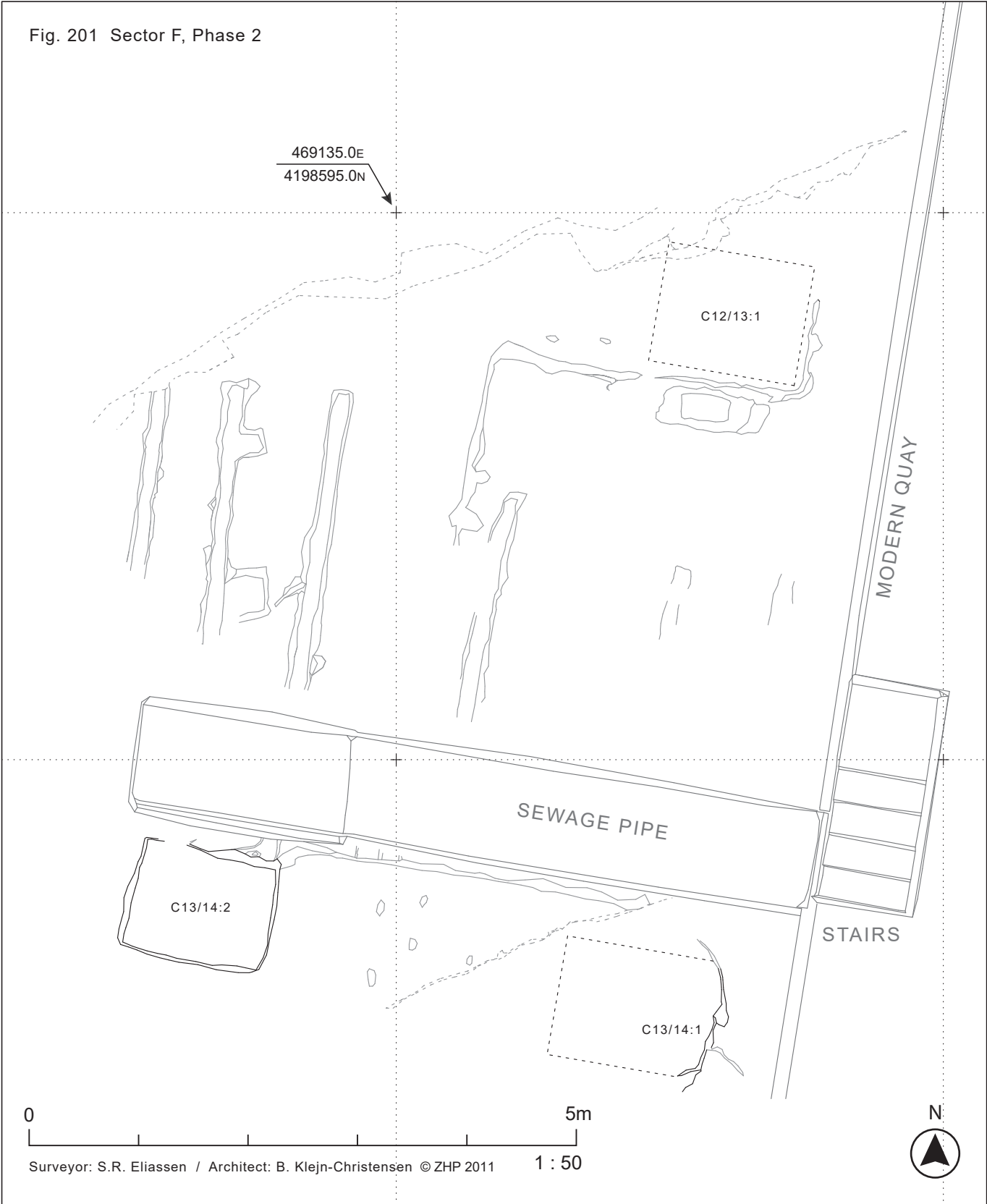

Fig. 202 Sector F, Phase 3

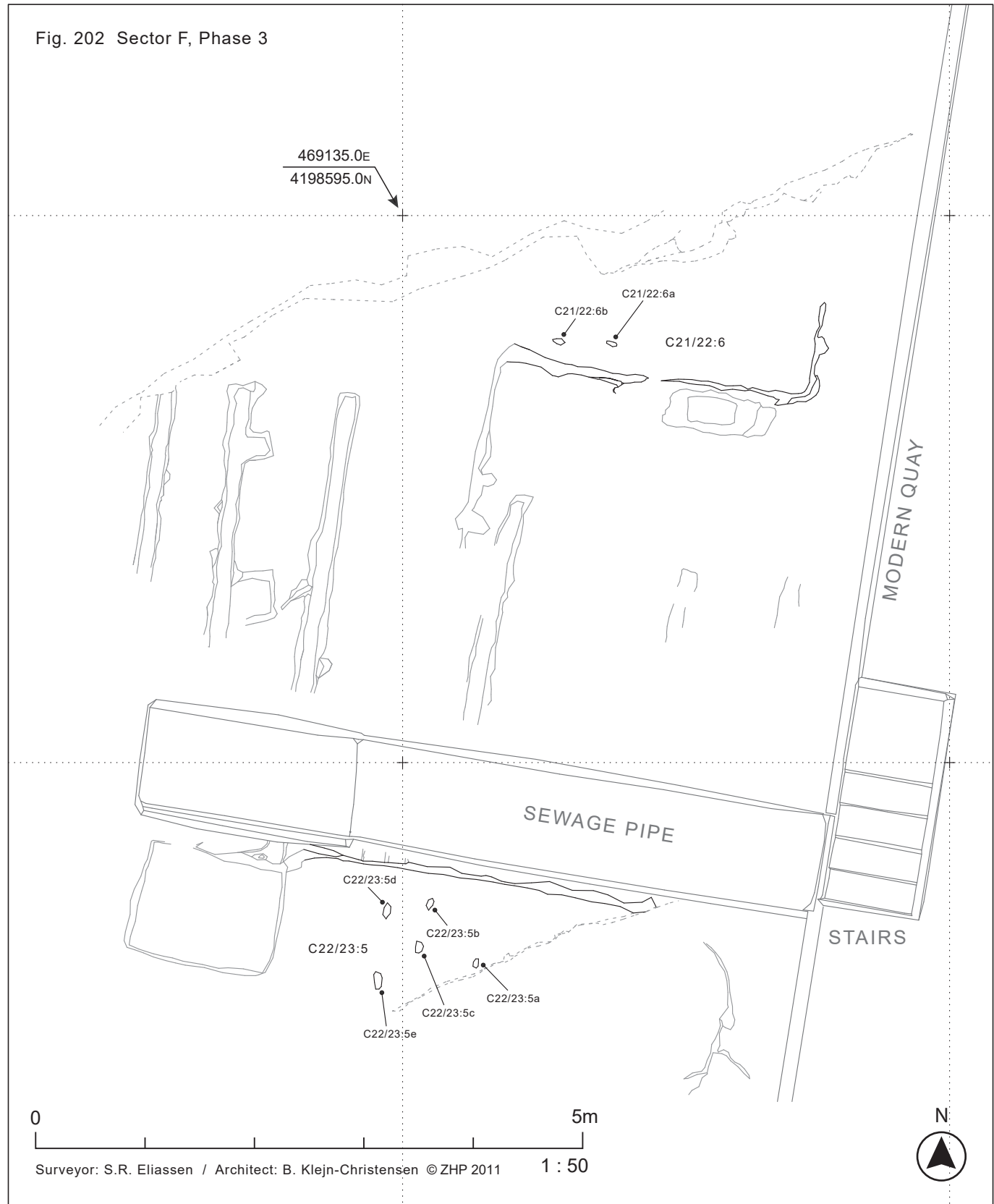
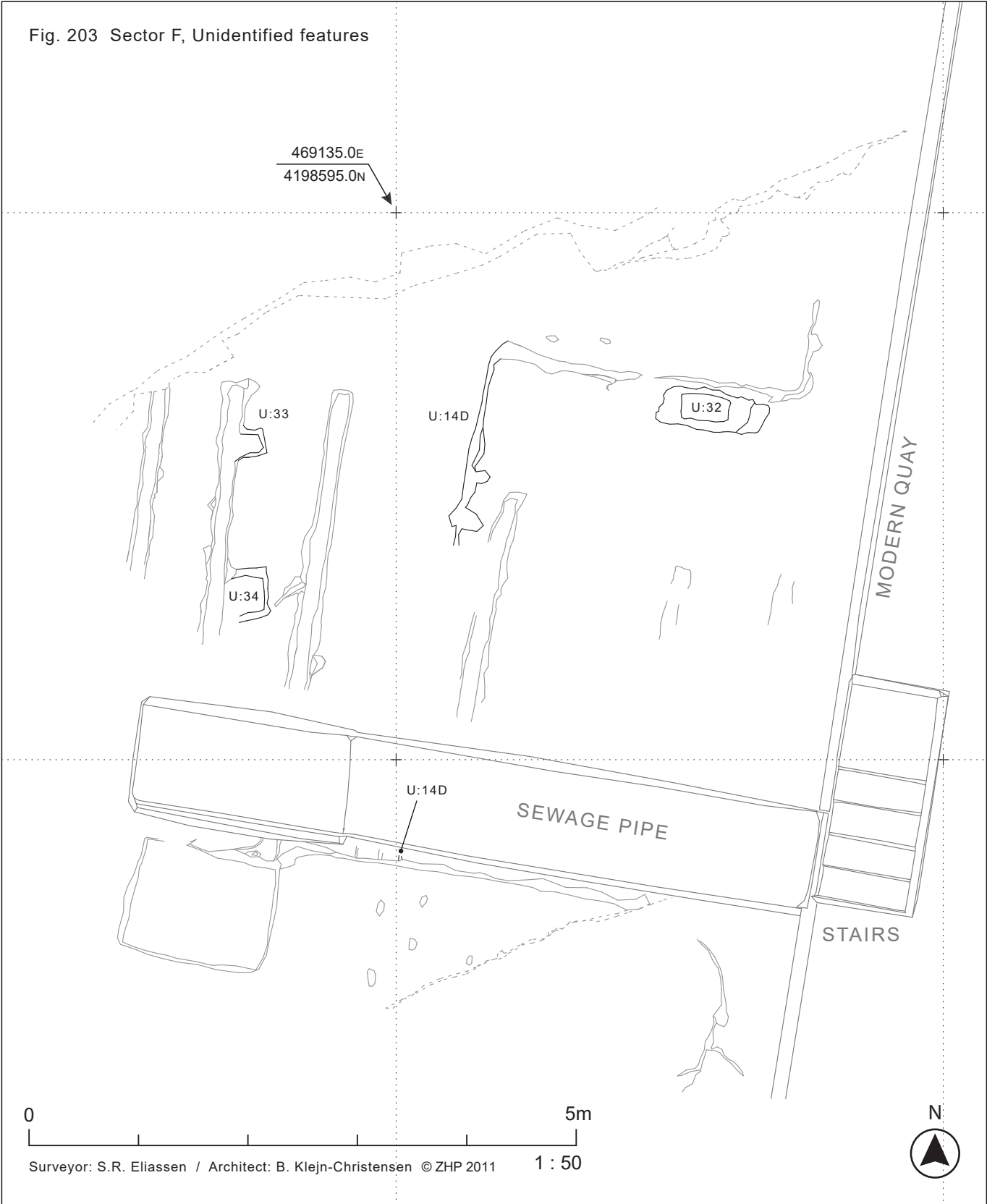

Fig. 203 Sector F, Unidentified features



0 5m
Surveyor: S.R. Eliassen / Architect: B. Klejn-Christensen © ZHP 2011 1 : 50



Fig. 204 Sector F, Section Key-map

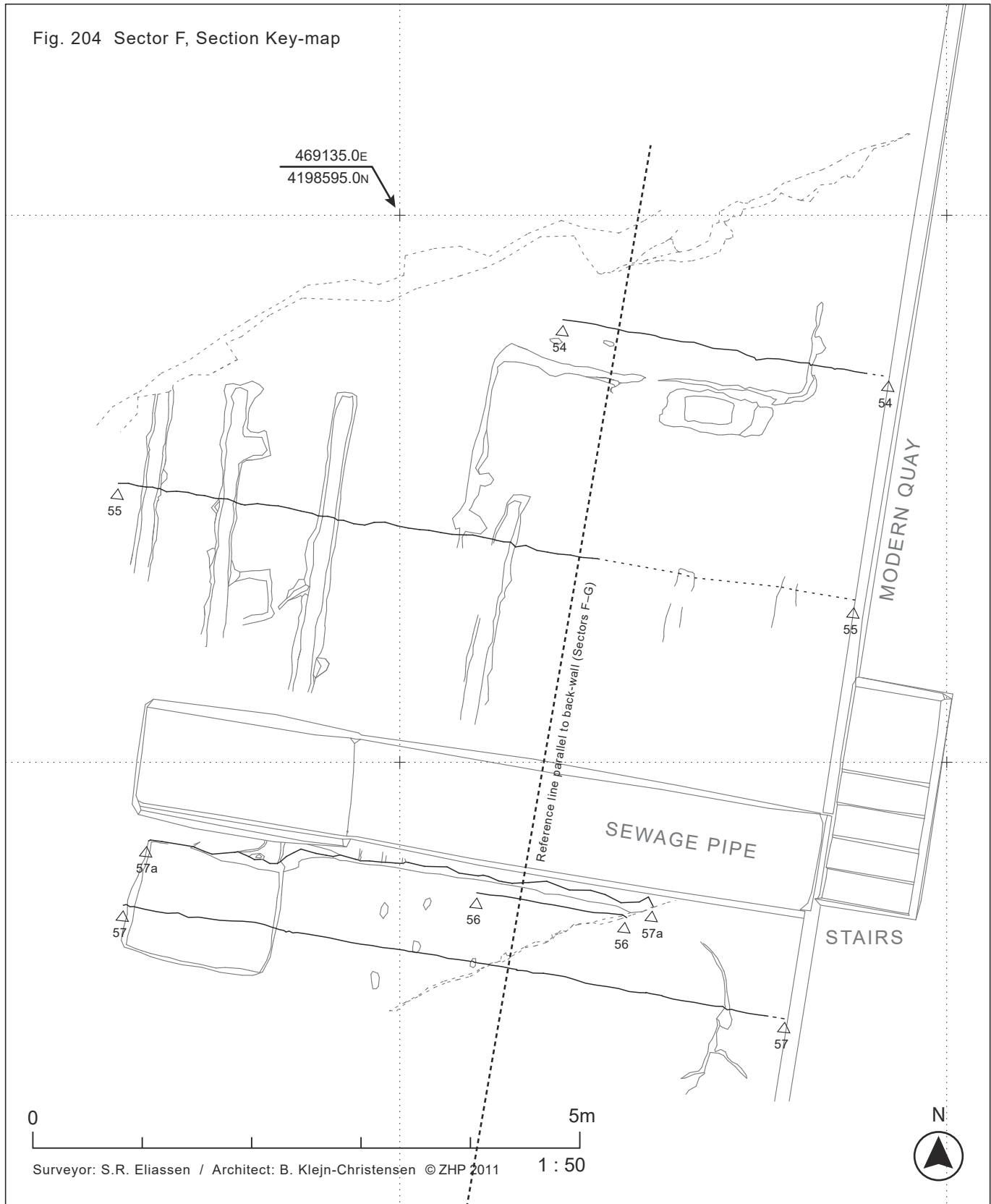
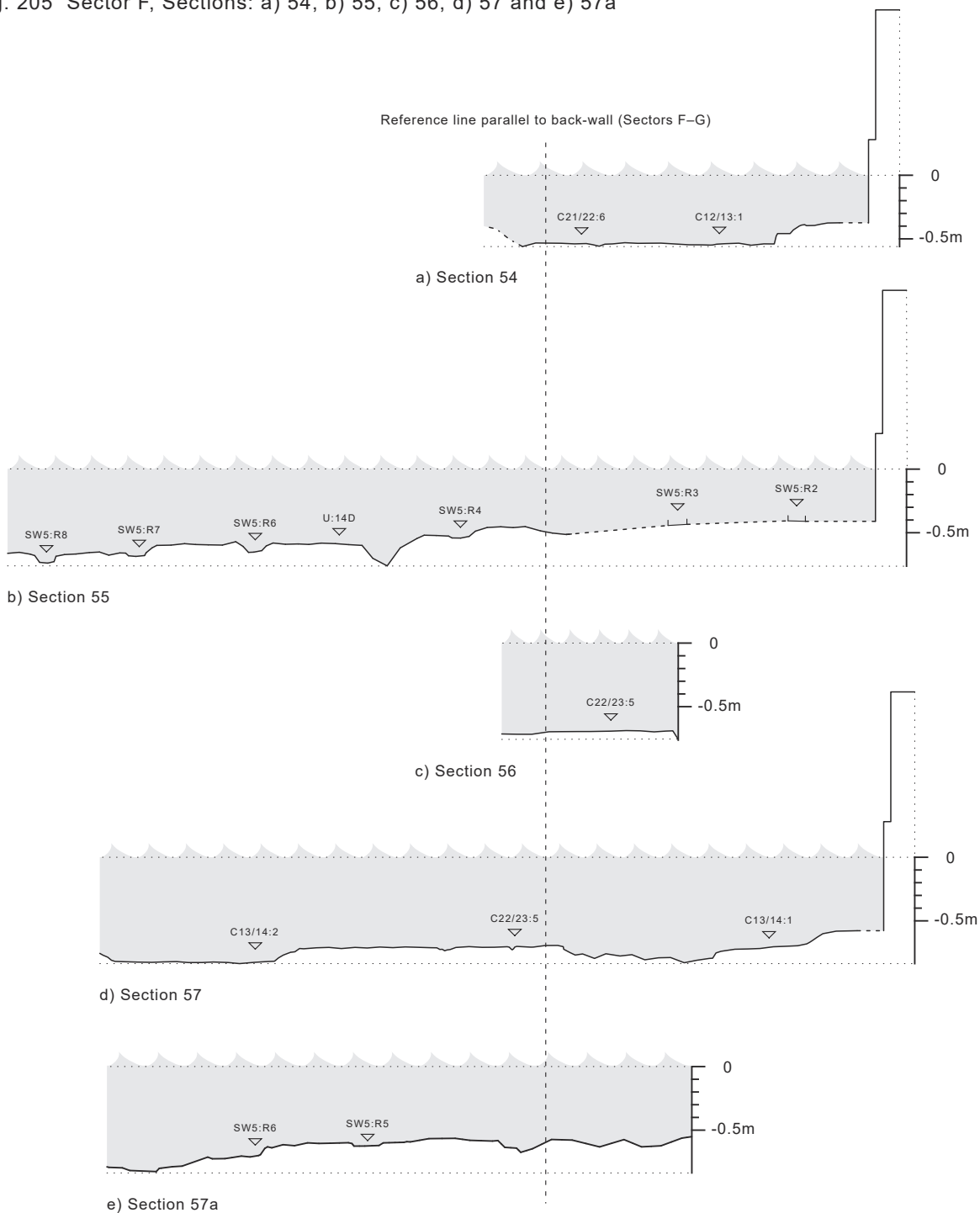

Fig. 205 Sector F, Sections: a) 54, b) 55, c) 56, d) 57 and e) 57a



0 5m

Surveyor: S.R. Eliassen / Architect: B. Klejn-Christensen © ZHP 2011 1 : 50

Fig. 206 Sector G, Phase 1

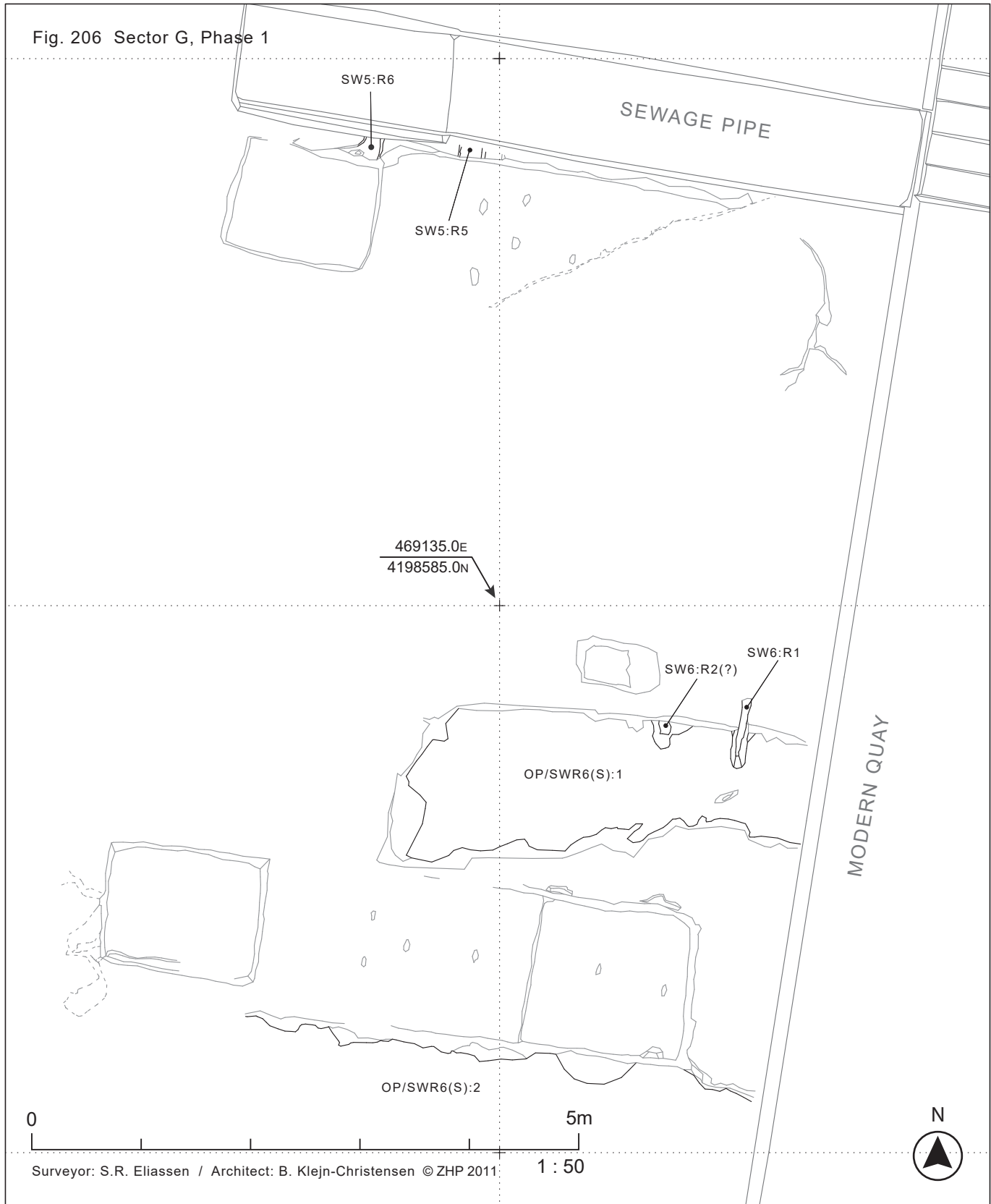

Surveyor: S.R. Eliassen / Architect: B. Klejn-Christensen © ZHP 2011

1 : 50

Fig. 207 Sector G, Phase 2

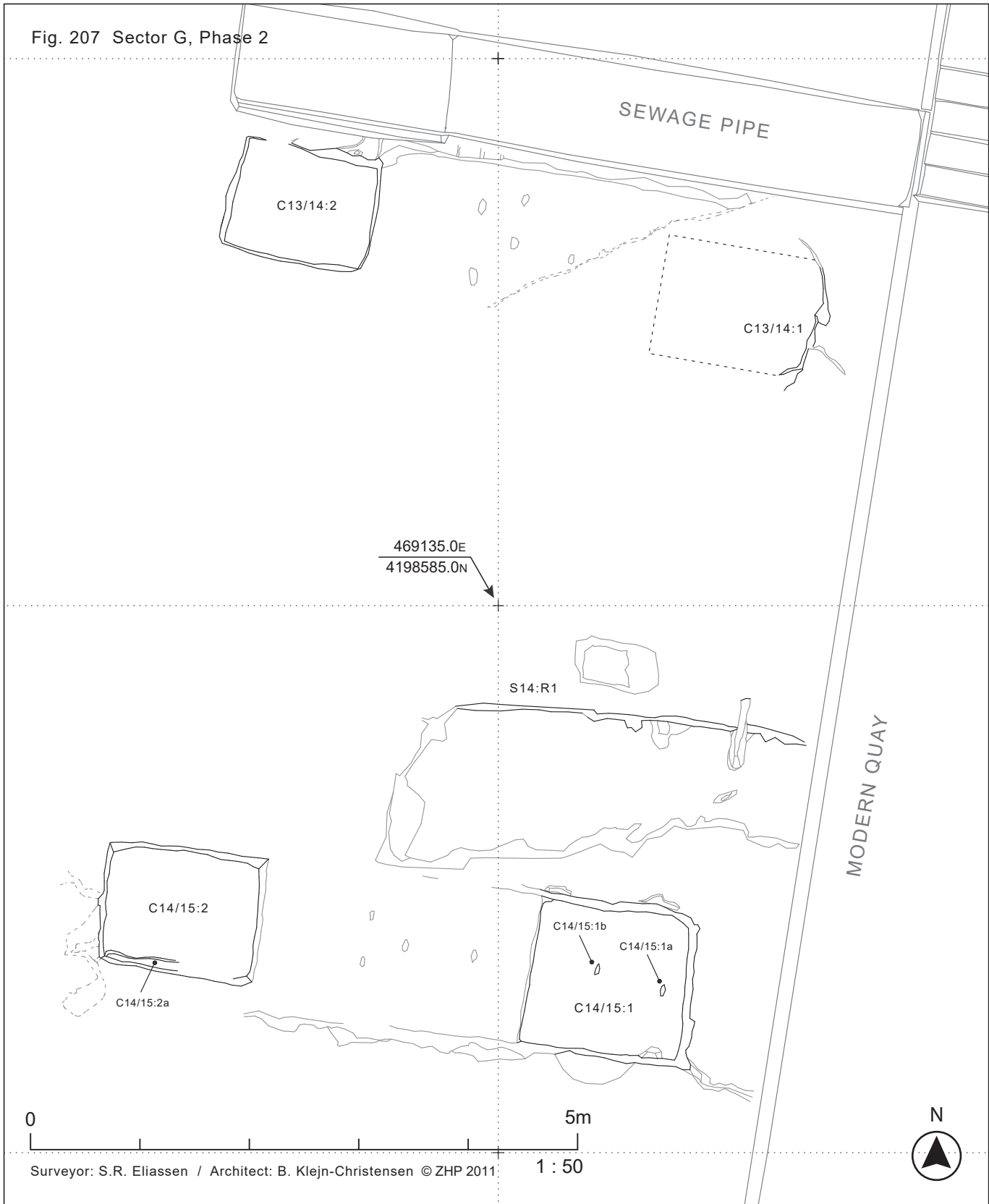

Surveyor: S.R. Eliassen / Architect: B. Klejn-Christensen © ZHP 2011

1 : 50

Fig. 208 Sector G, Phase 3

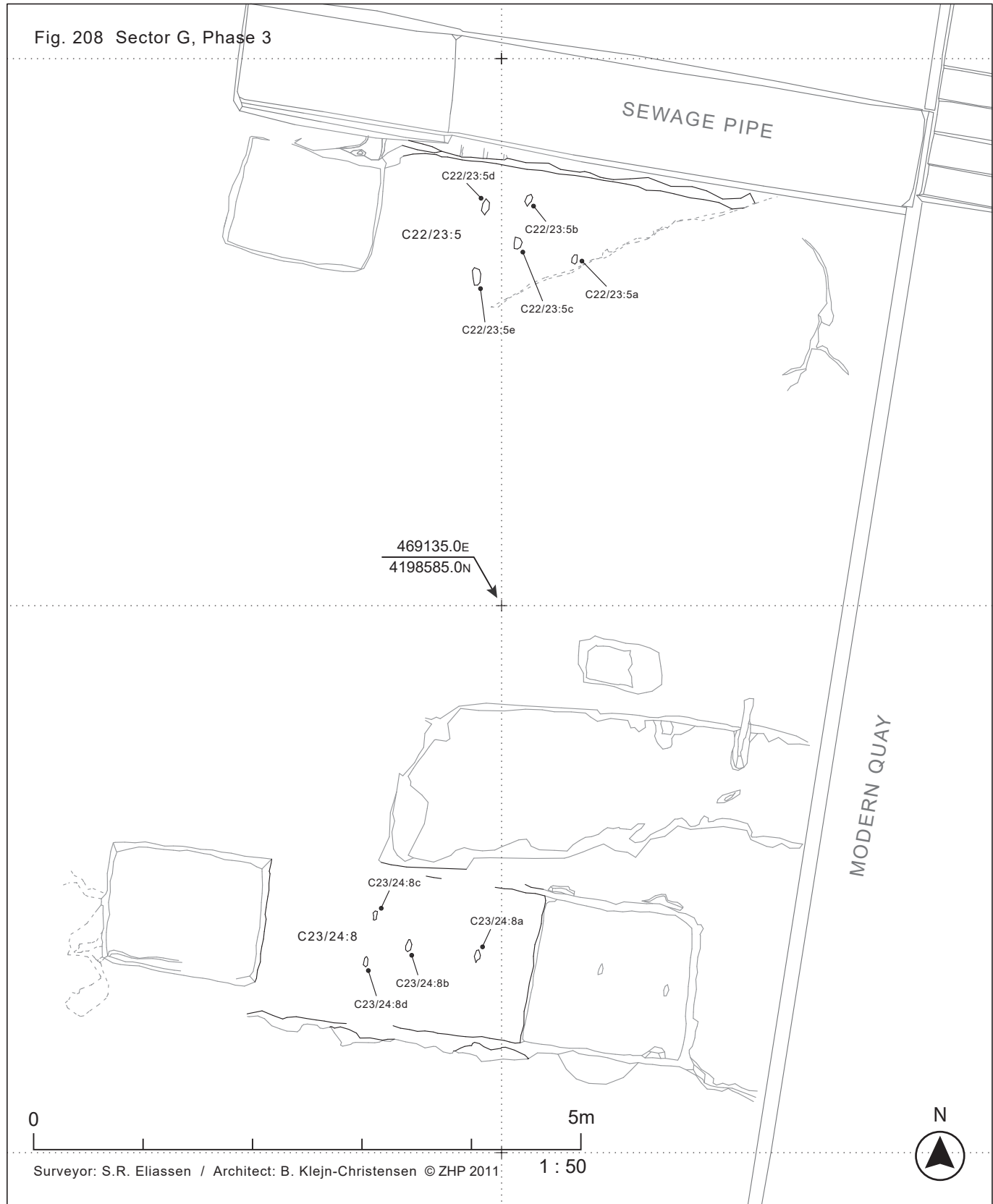

0

5m

Surveyor: S.R. Eliassen / Architect: B. Klejn-Christensen © ZHP 2011

1 : 50



Fig. 209 Sector G, Unidentified features

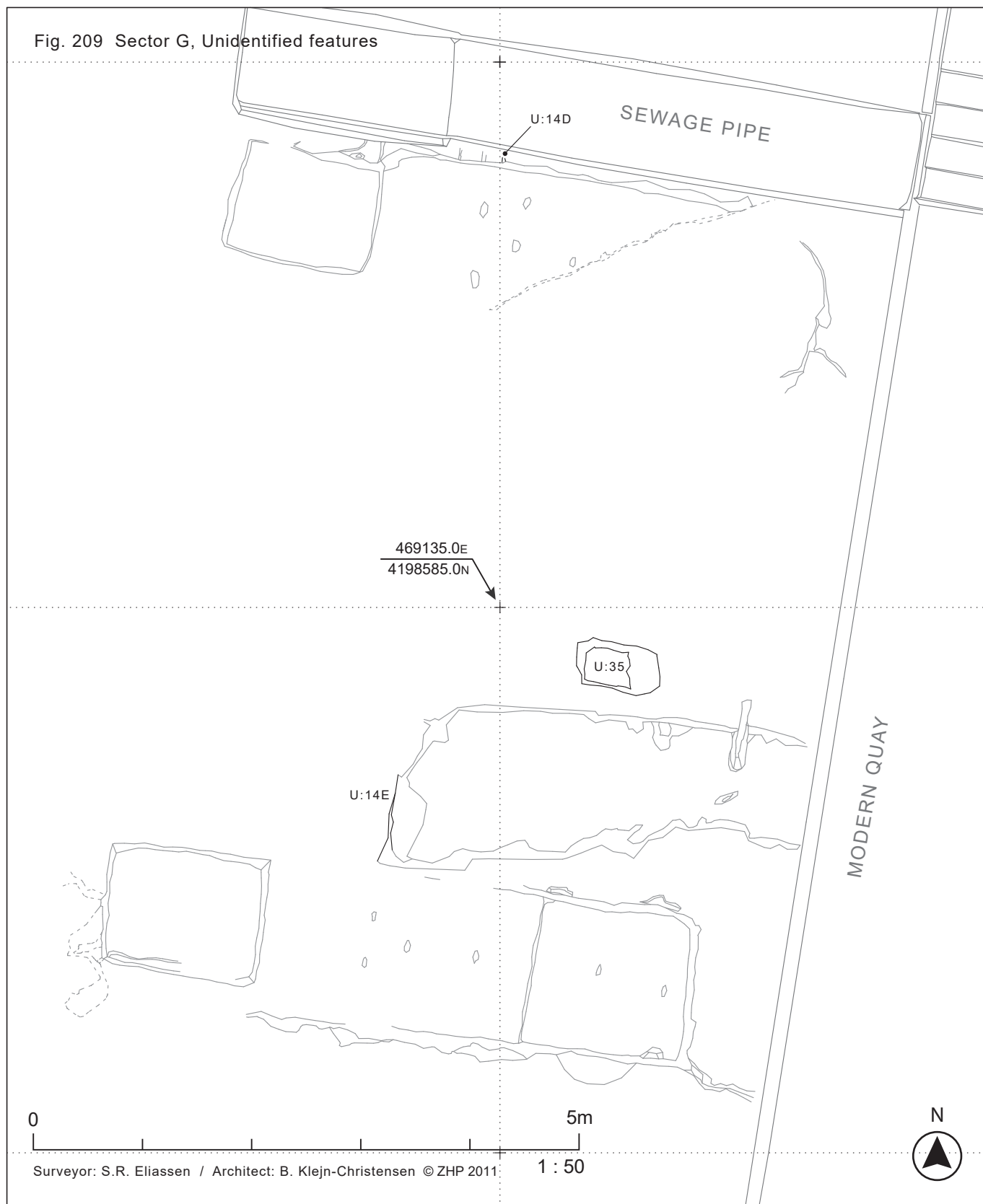

Surveyor: S.R. Eliassen / Architect: B. Klejn-Christensen © ZHP 2011

1 : 50

Fig. 210 Sector G, Section Key-map

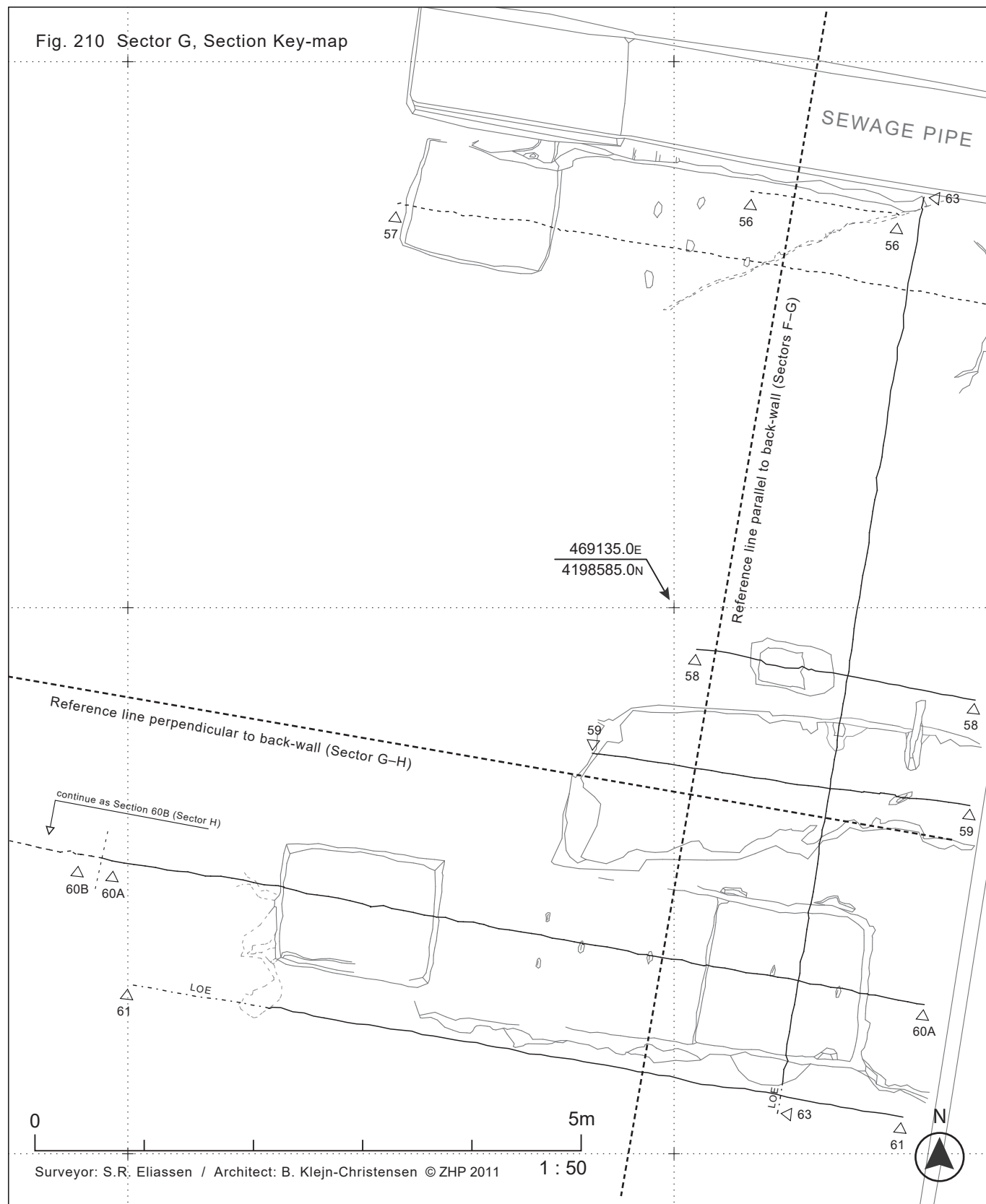

Surveyor: S.R. Eliassen / Architect: B. Klejn-Christensen © ZHP 2011

1 : 50

Fig. 211 Sector G, Sections: a) 58, b) 59, c) 60A and d) 61

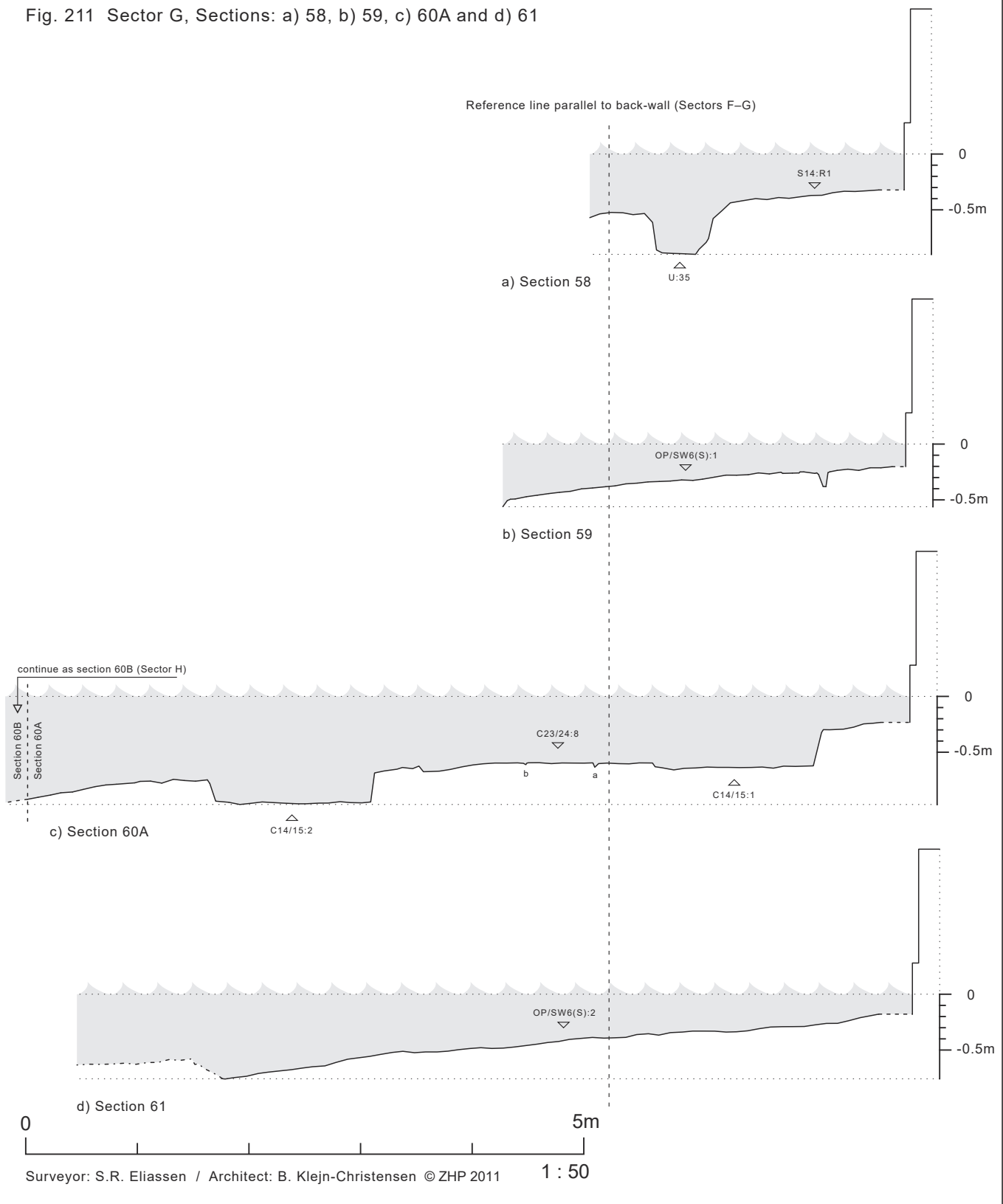
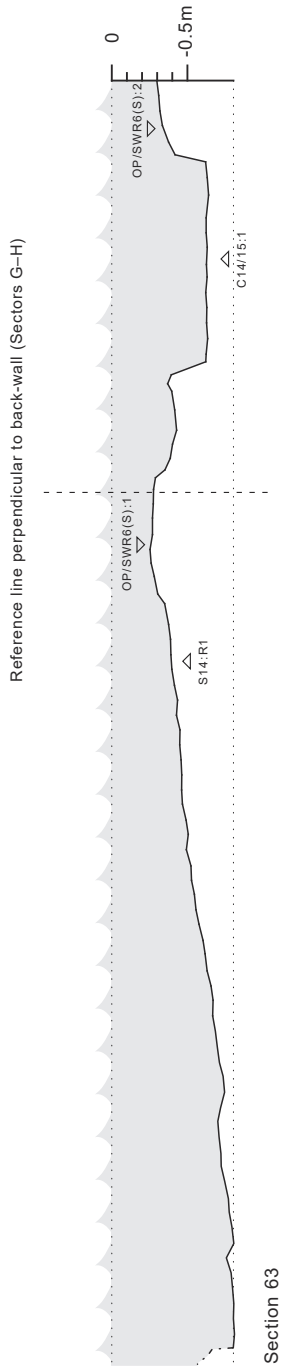
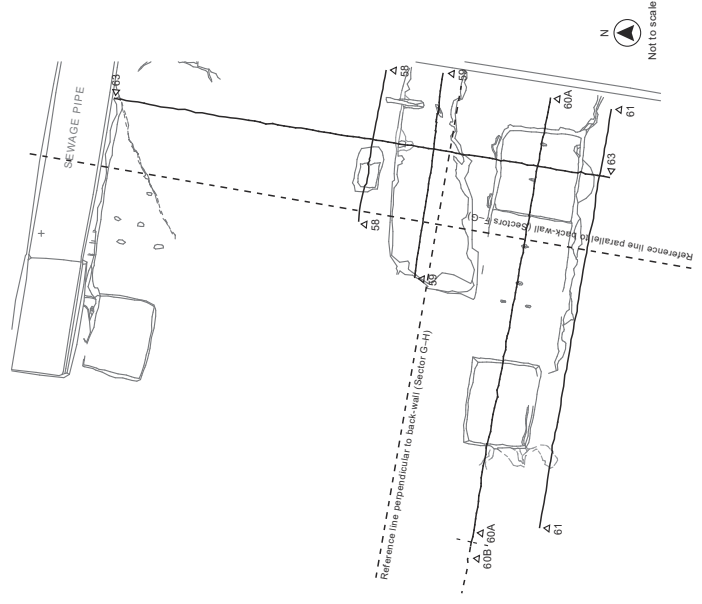

Fig. 212 Sector G, Section 63



Section 63



Surveyor: S.R. Eliassen / Architect: B. Klejn-Christensen © ZHP 2011 1 : 50

Fig. 213 Sector H, Phase 2

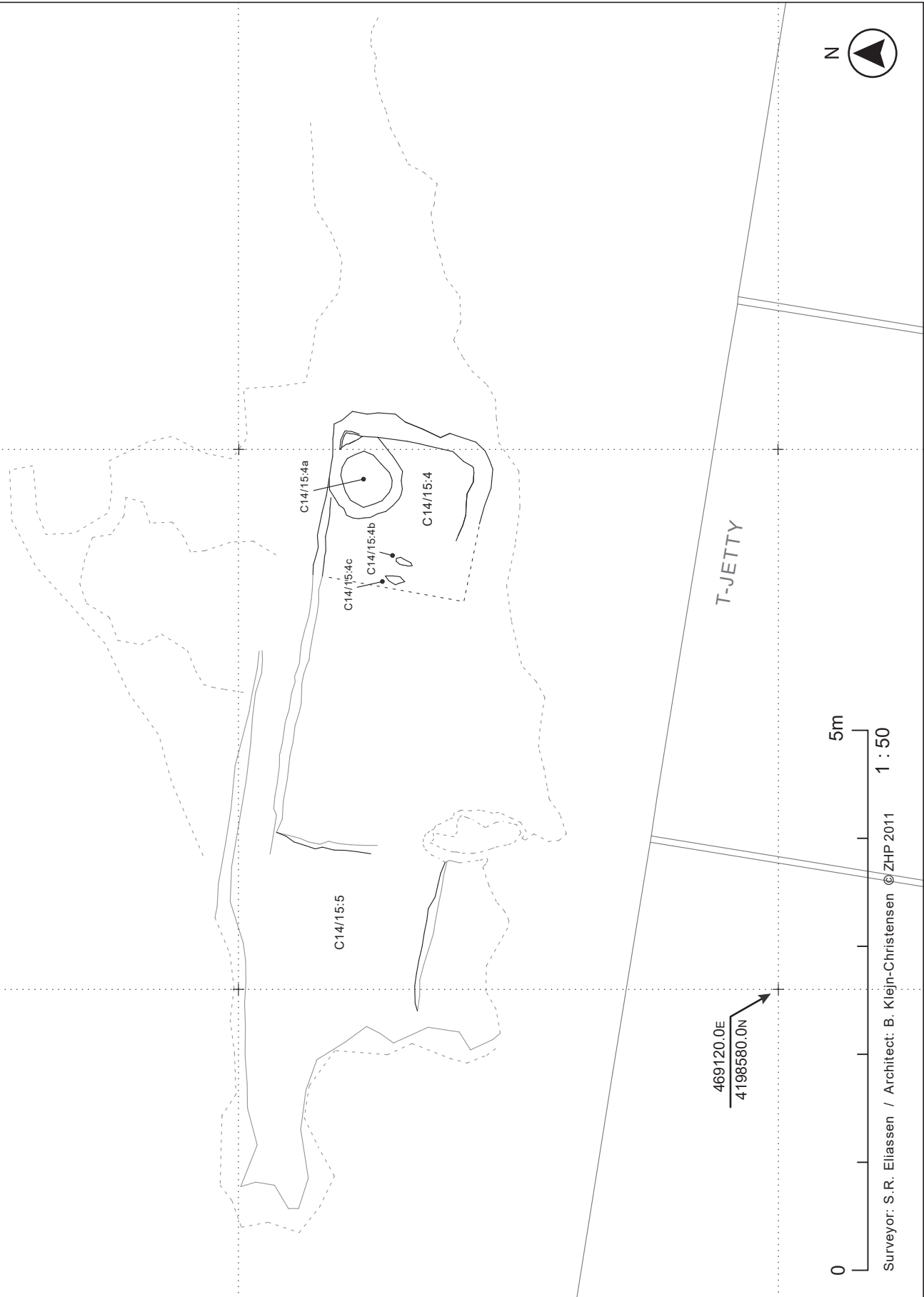

Fig. 214 Sector H, Phase 3

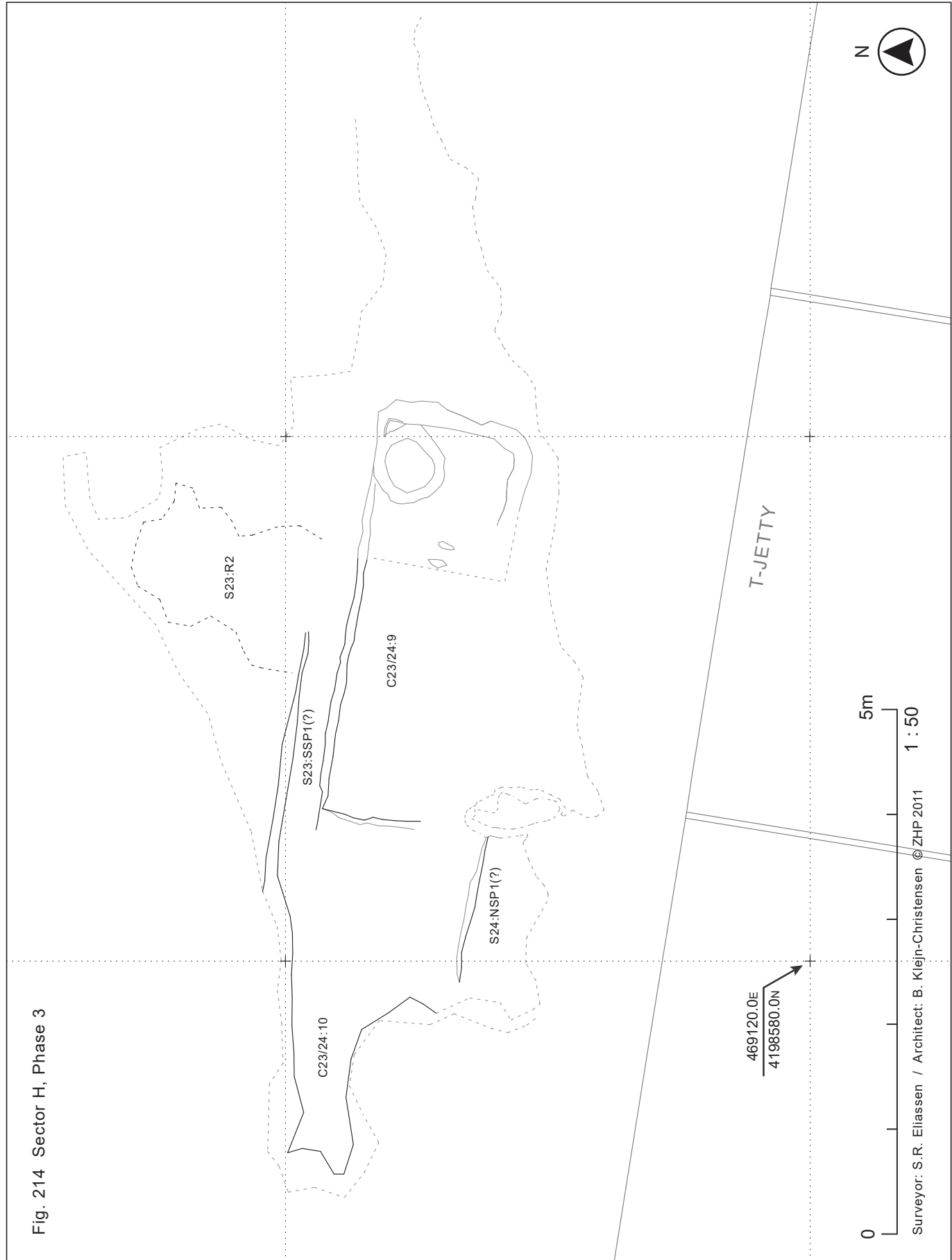
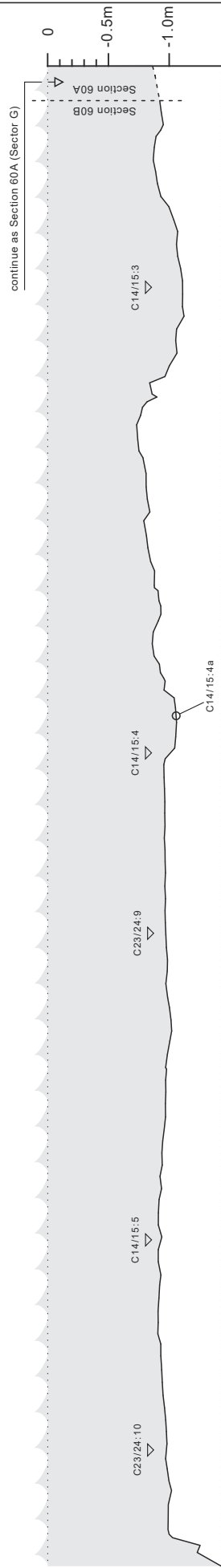

Fig. 215 Sector H, Section Key-map



Fig. 216 Sector H, Sections: a) 60B and b) 62



a) Section 60B

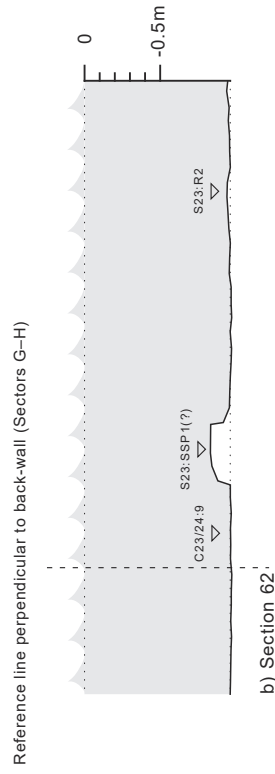

b) Section 62:

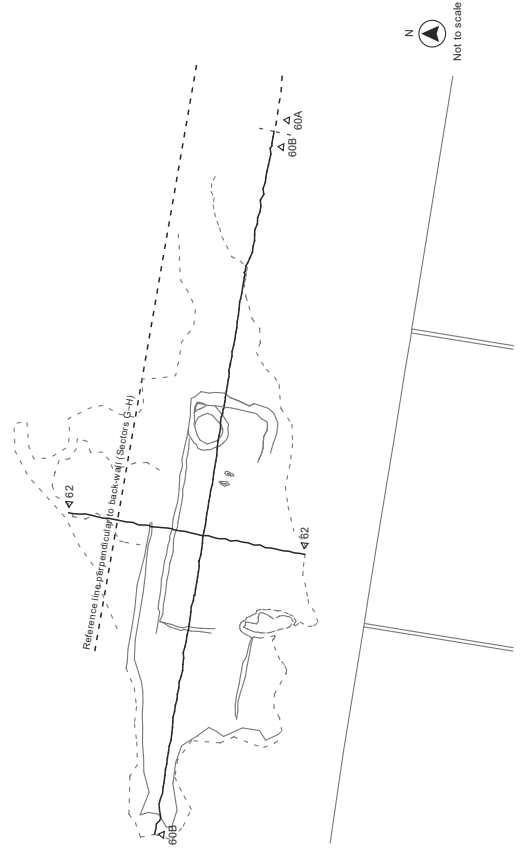

Surveyor: S.R. Eliassen / Architect: B. Kleijn-Christensen © ZHP 2011

Fig. 217 Slipway 3, gradients of ramp structure (Section 47)

Ramp of SW3 (Sec 47): points representing the best preserved top surfaces

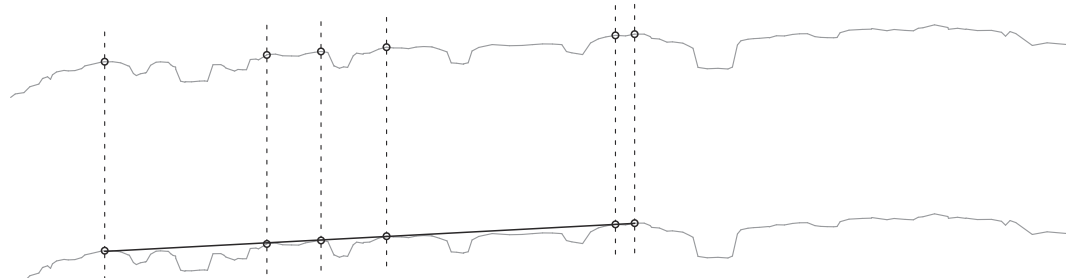

Ramp of SW3 (Sec 47): linear regression through 6 points representing best preserved top surfaces

a) Ramp of SW3 (Sec 47), G2-T (based on 6 points): 1:18.9 (3.0°)

Ramp of SW3 (Sec 47): points representing the best preserved bottom surfaces

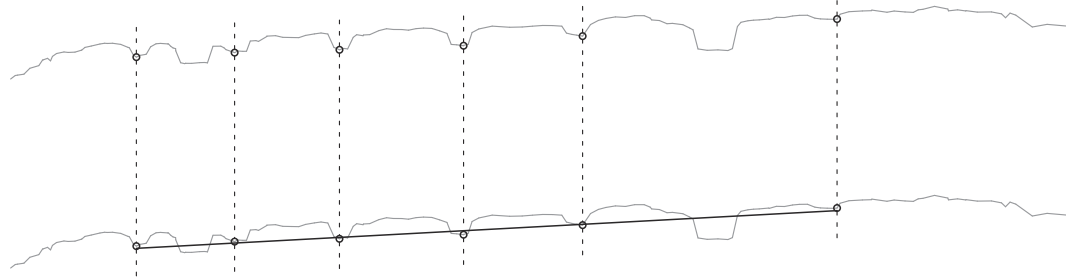

Ramp of SW3 (Sec 47): linear regression through 6 points representing best preserved bottom surfaces

b) Ramp of SW3 (Sec 47), G3-B (based on 6 points): 1:18.6 (3.1°)



Surveyor: Eliassen / Architect: Klejn-Christensen / Data: Lovén © ZHP 2011 1 : 50

Fig. 218 Slipway 5, gradients of ramp structure (Section 55)

Ramp of SW5 (Sec 55): points representing the best preserved top surfaces

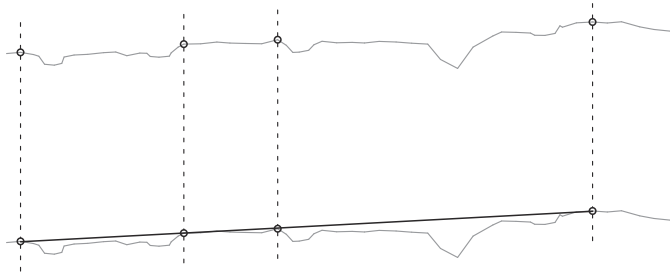

Ramp of SW5 (Sec 55): linear regression through 4 points representing best preserved top surfaces

a) Ramp of SW5 (Sec 55), G2-T (based on 4 points): 1:18.7 (3.1°)

Ramp of SW5 (Sec 55): points representing the best preserved bottom surfaces

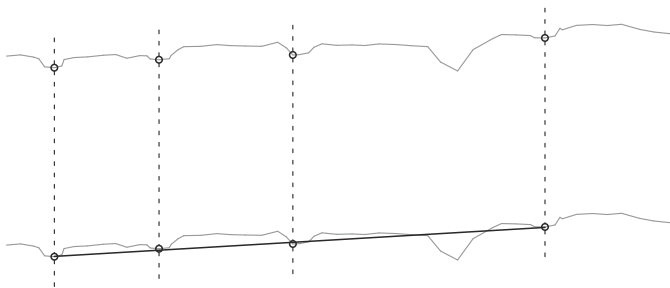

Ramp of SW5 (Sec 55): linear regression through 4 points representing best preserved bottom surfaces

b) Ramp of SW5 (Sec 55), G3-B (based on 4 points): 1:16.9 (3.4°)



Surveyor: Eliassen / Architect: Klejn-Christensen / Data: Lovén © ZHP 2011 1 : 50

Fig. 219 Gradient of open-passages south of the ramp in Slipway 3 (Section 48) and Slipway 6 (Section 61)

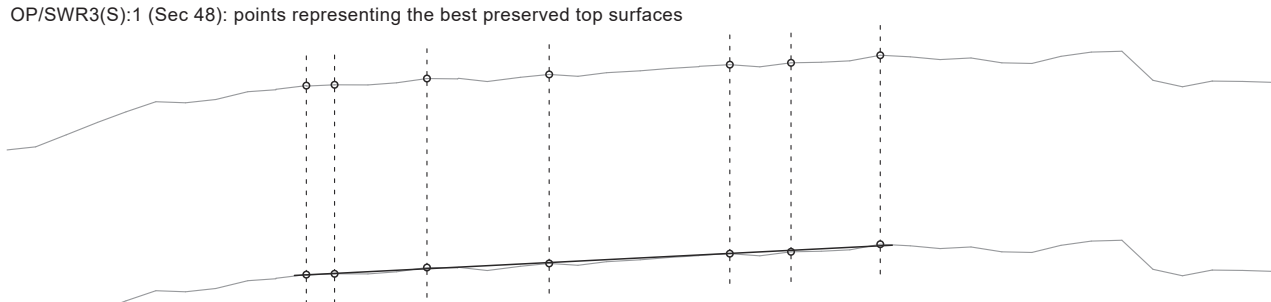

OP/SWR3(S):1 (Sec 48): linear regression through 7 points representing best preserved top surfaces

a) OP/SWR3(S):1 (Sec 48): G2-T (based on 7 points): 1:19.8 (2.9°)

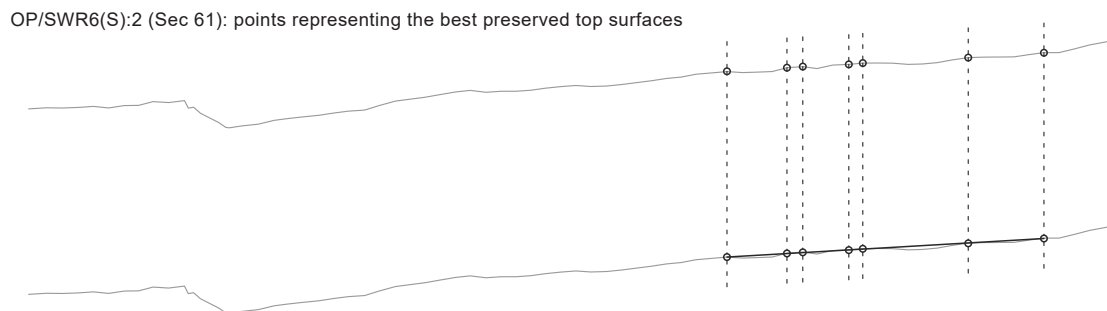

OP/SWR6(S):2 (Sec 61): linear regression through 7 points representing best preserved top surfaces

b) OP/SWR6(S):2 (Sec 61), G2-T (based on 7 points): 1:17.0 (3.4°)



Surveyor: Eliassen / Architect: Klejn-Christensen / Data: Lovén © ZHP 2011 1 : 50

Fig. 220 Wall 16/26(A), gradients of rock-cut foundation trenches and 1st course of blocks (Section 25, land):
 a) W16/26:1; b) W16/26:2A; c) W16/26:2B and d) W16/26:9-11

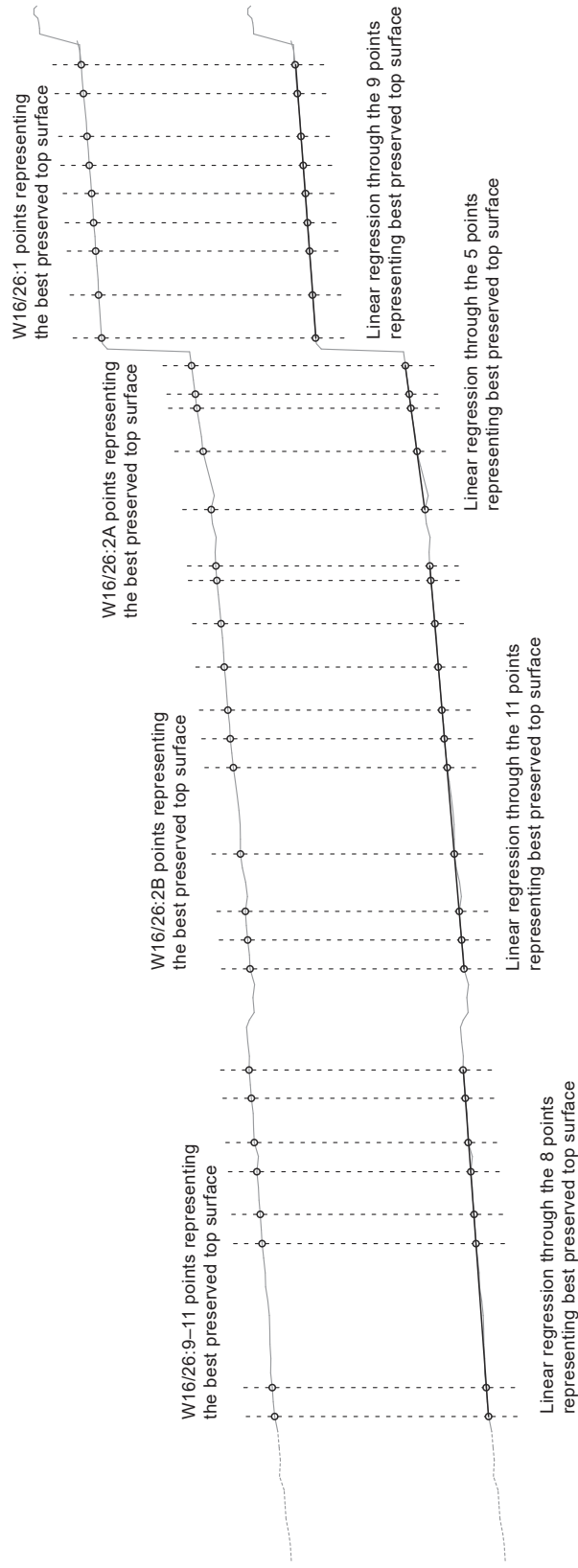

- a) Wall 16/26:1 (Sec 25), G3-B (based on 9 points): 1:13.5 (4.2°)
- b) Wall 16/26:2A (Sec 25), G3-B (based on 5 points): 1:7.4 (7.7°)
- c) Wall 16/26:2B (Sec 25), G3-B (based on 11 points): 1:11.8 (4.9°)
- d) Wall 16/26:9-11 (Sec 25), G2-T (based on 8 points): 1:13.8 (4.2°)



Fig. 221 Wall 16/26(A), gradients of AE:6, 2nd course of blocks (Section 24, land), and rock-cut foundation trenches (Section 24, sea): a) AE:4; b) W16/26:12-13; c) W16/26:4, 6

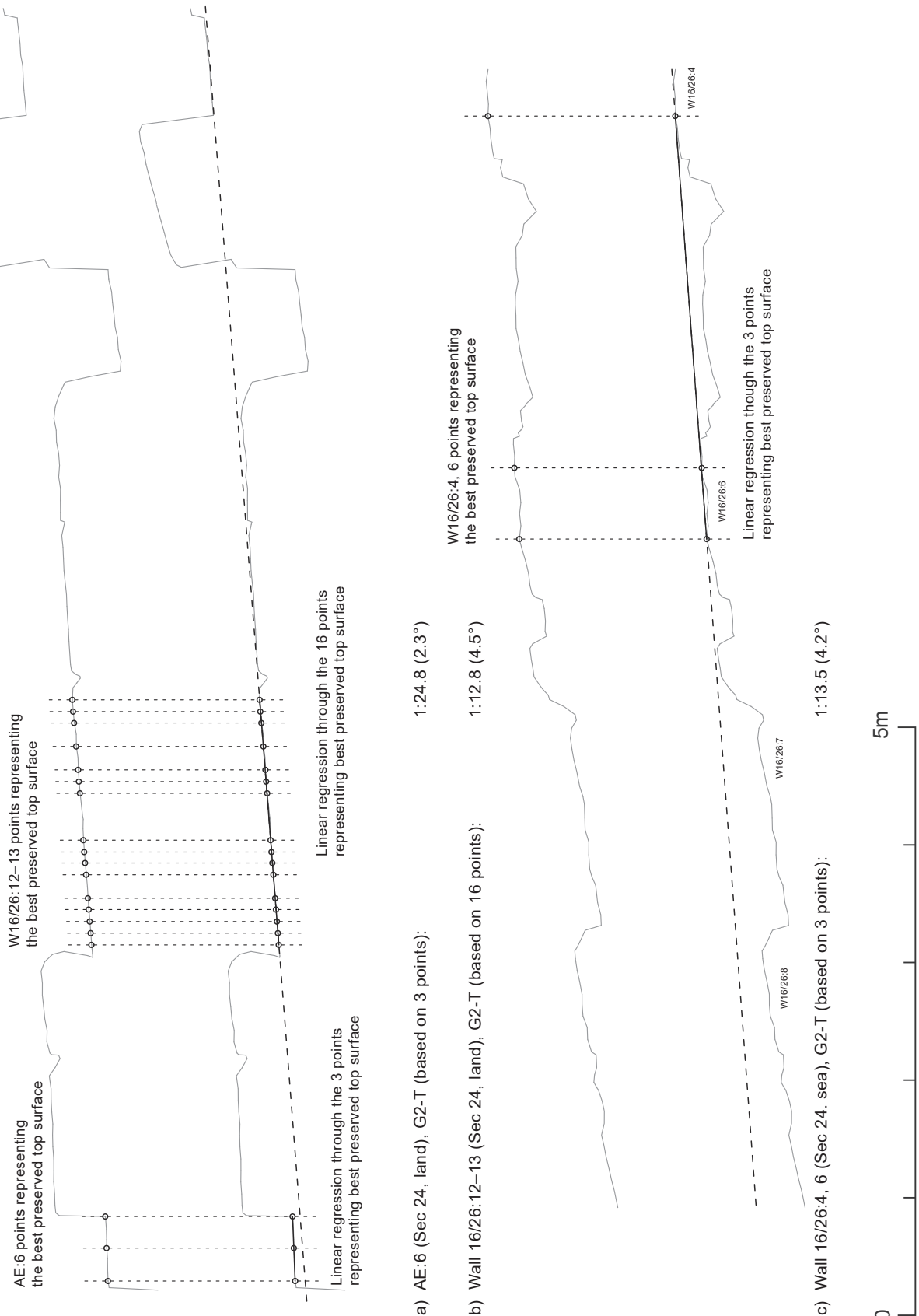

Surveyor: Eliassen / Architect: Kleijn-Christensen / Data: Lovén © ZHP 2011 1 : 50

Fig. 222 Gradients of Section 31(sea) and Section 33(sea)

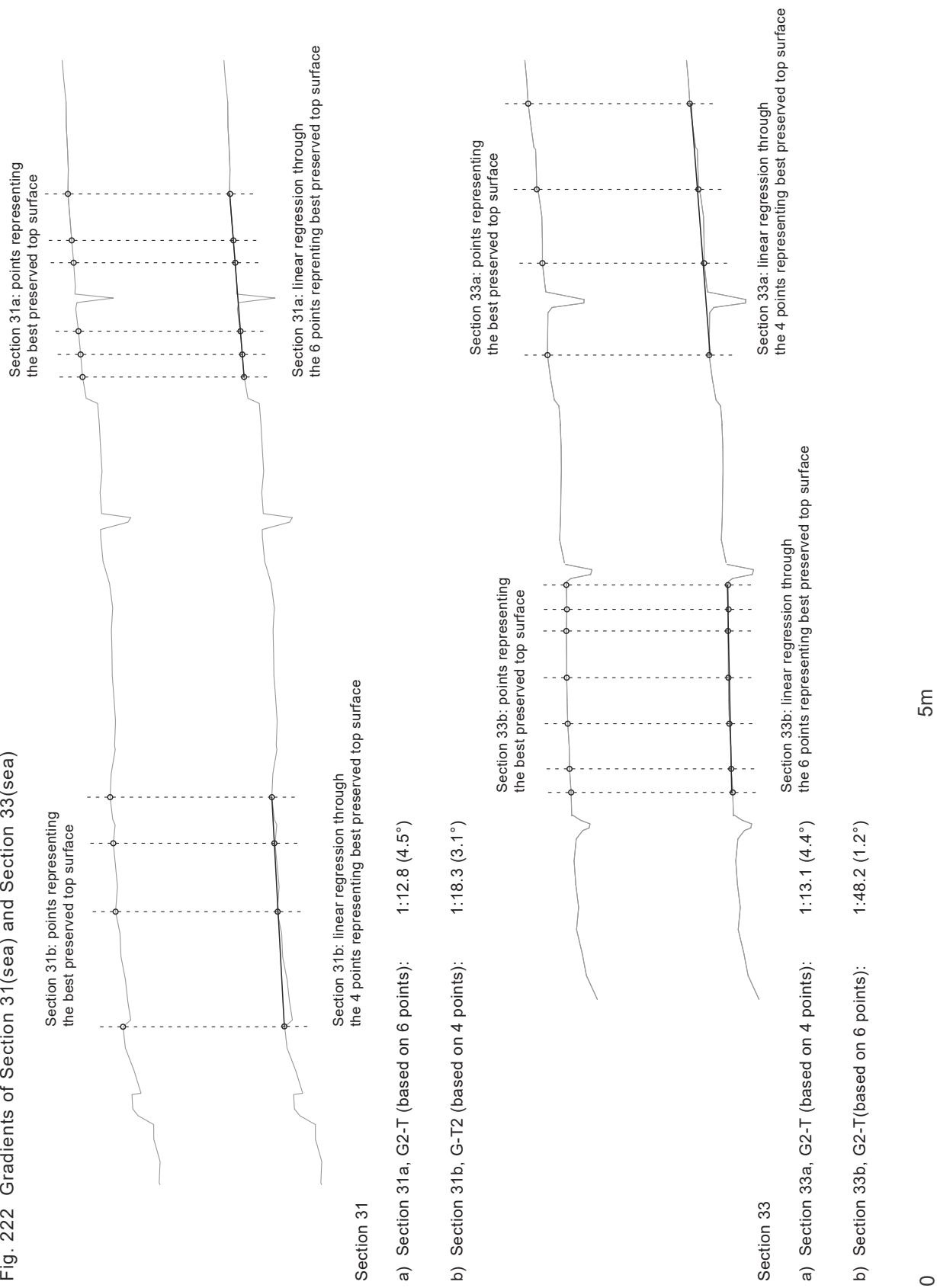
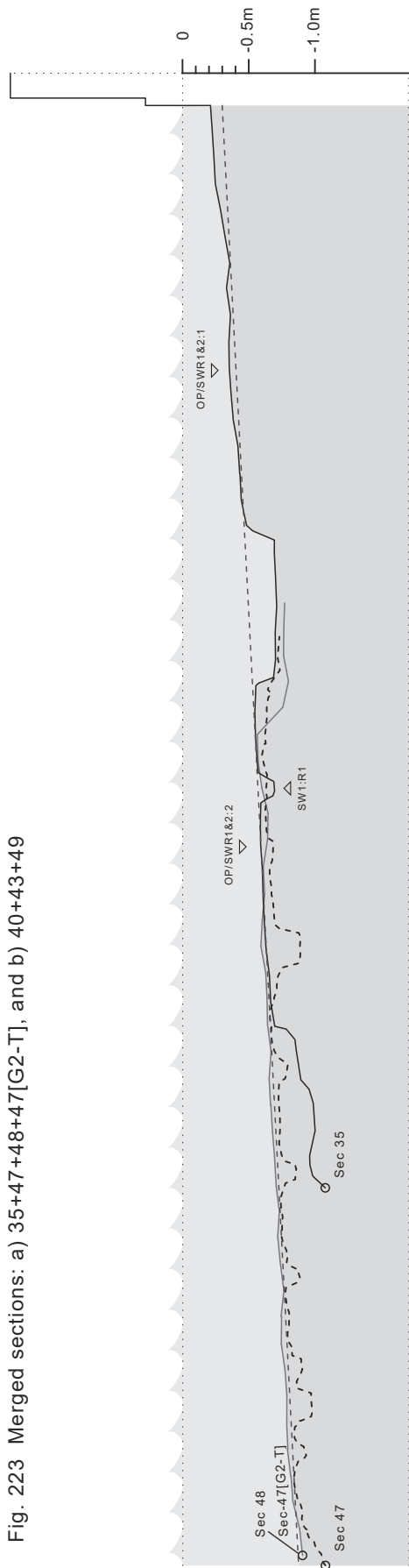
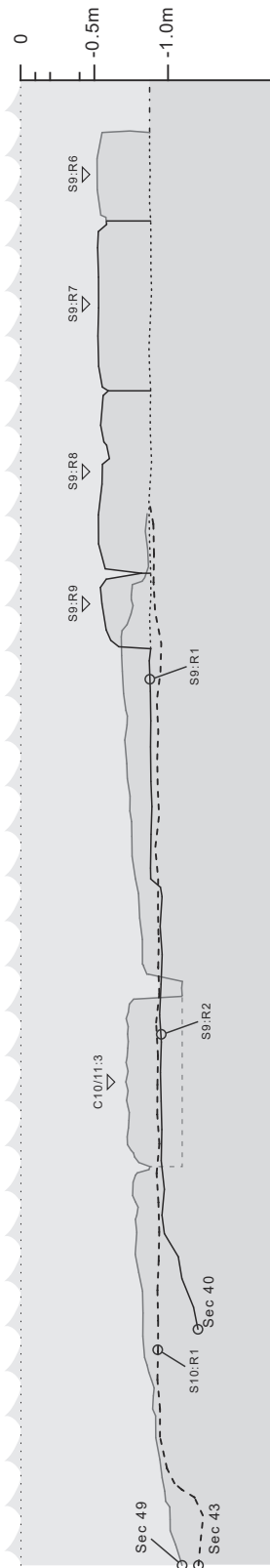

Fig. 223 Merged sections: a) 35+47+48+47[G2-T], and b) 40+43+49



a) Merged sections 35+47+48+47[G2-T]



b) Merged sections 40+43+49



Fig. 224 Merged sections: a) SW2-rec+39, b) SW2-rec+40+40b, and c) SW2-rec+41b

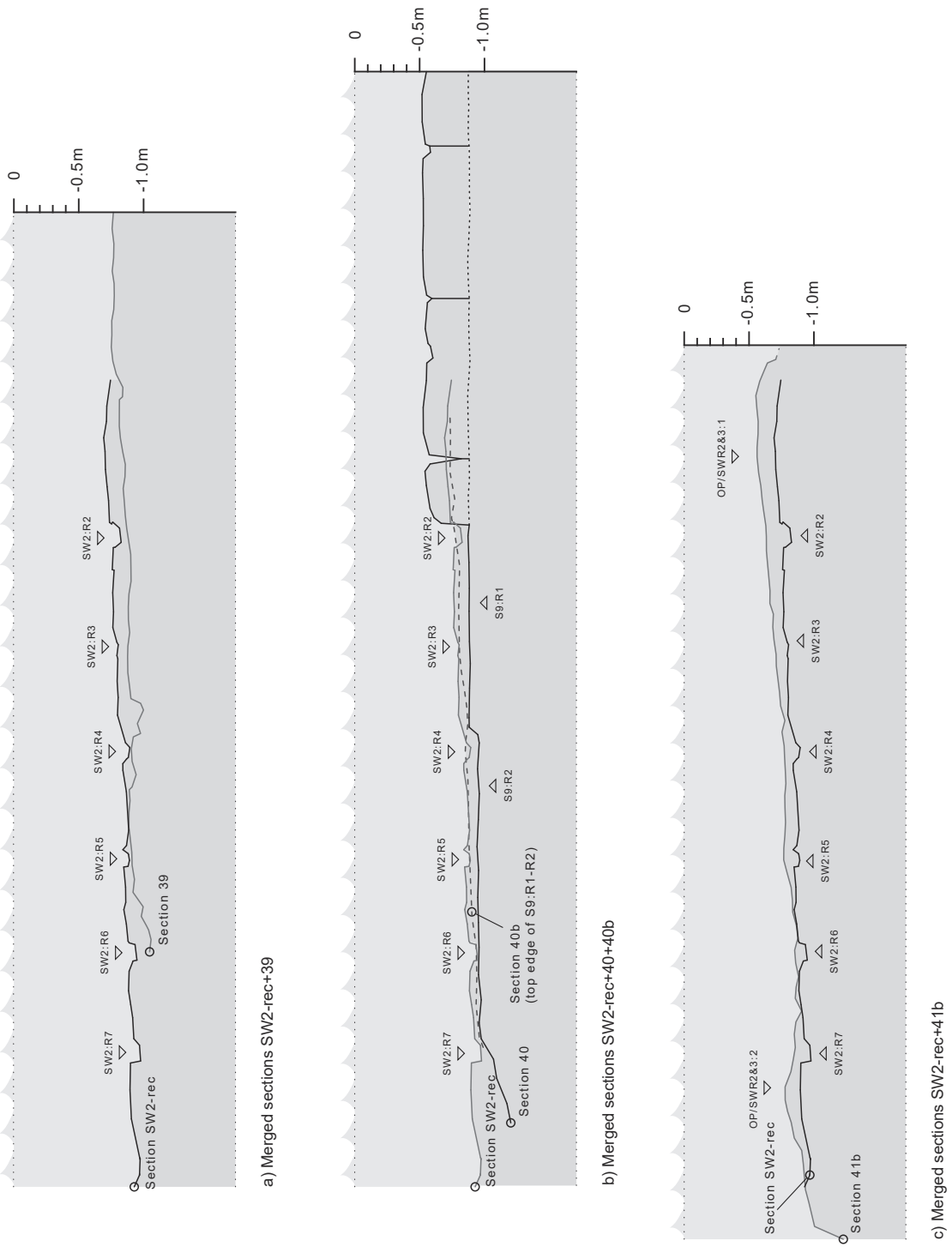
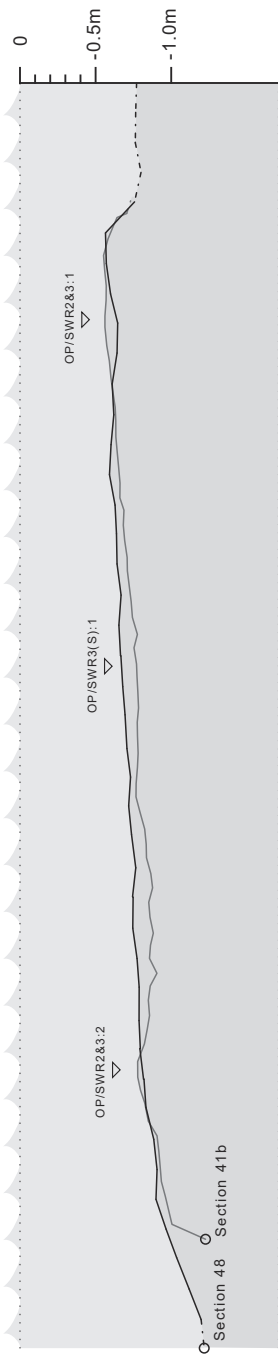
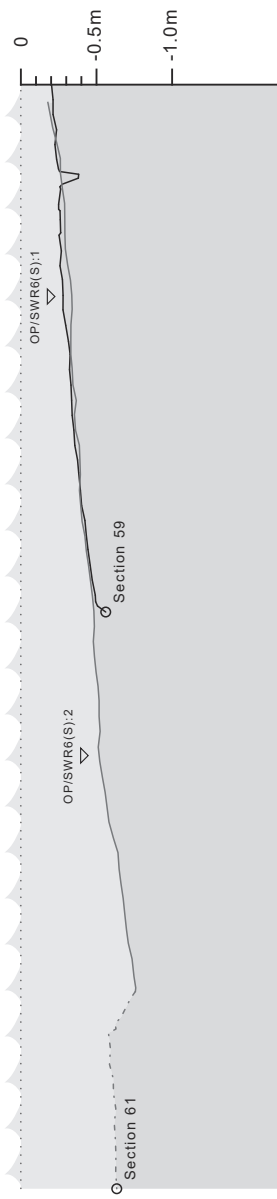

Fig. 225 Merged sections: a) 41b+48, and b) 59+61



a) Merged sections 41b+48



b) Merged sections 59+61



Surveyor: Eliassen / Architect: Klejn-Christensen / Data: Lovén © ZHP 2011 1 : 50

Fig. 226 Merged sections: a) 43+46, b) 44+46, and c) 43+44+46

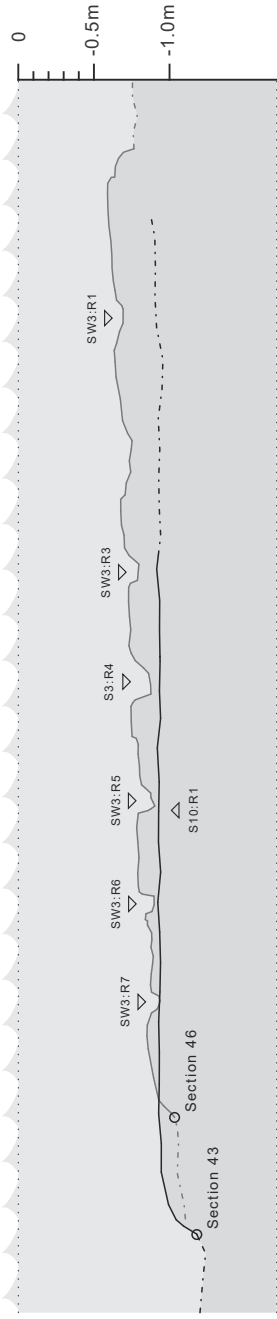

a) Merged sections 43+46

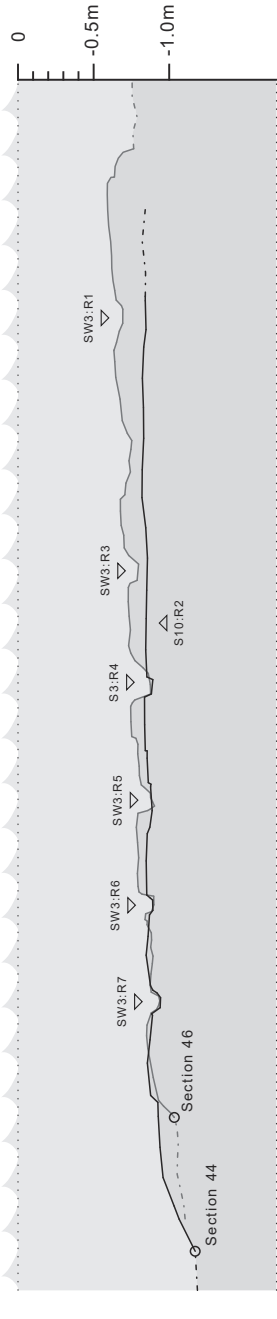

b) Merged sections 44+46

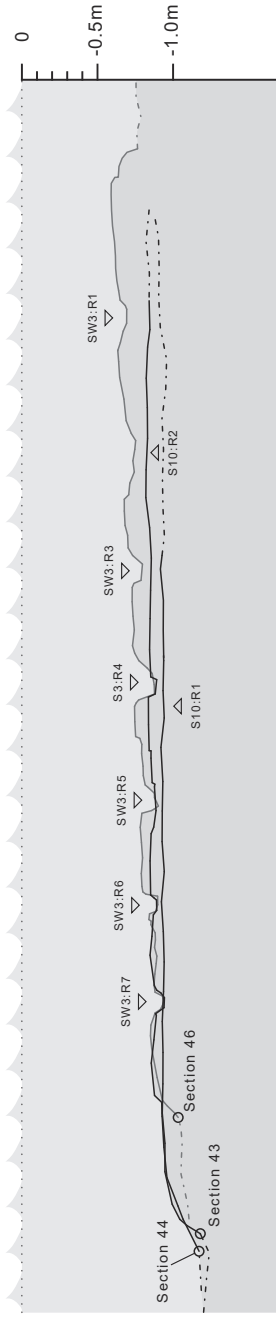

c) Merged sections 43+44+46

0 5m

Surveyor: Eliassen / Architect: Klejn-Christensen / Data: Lovén © ZHP 2011 1 : 50

Fig. 227 Merged sections: a) 55+56+57+57a, and b) 41b+42+46

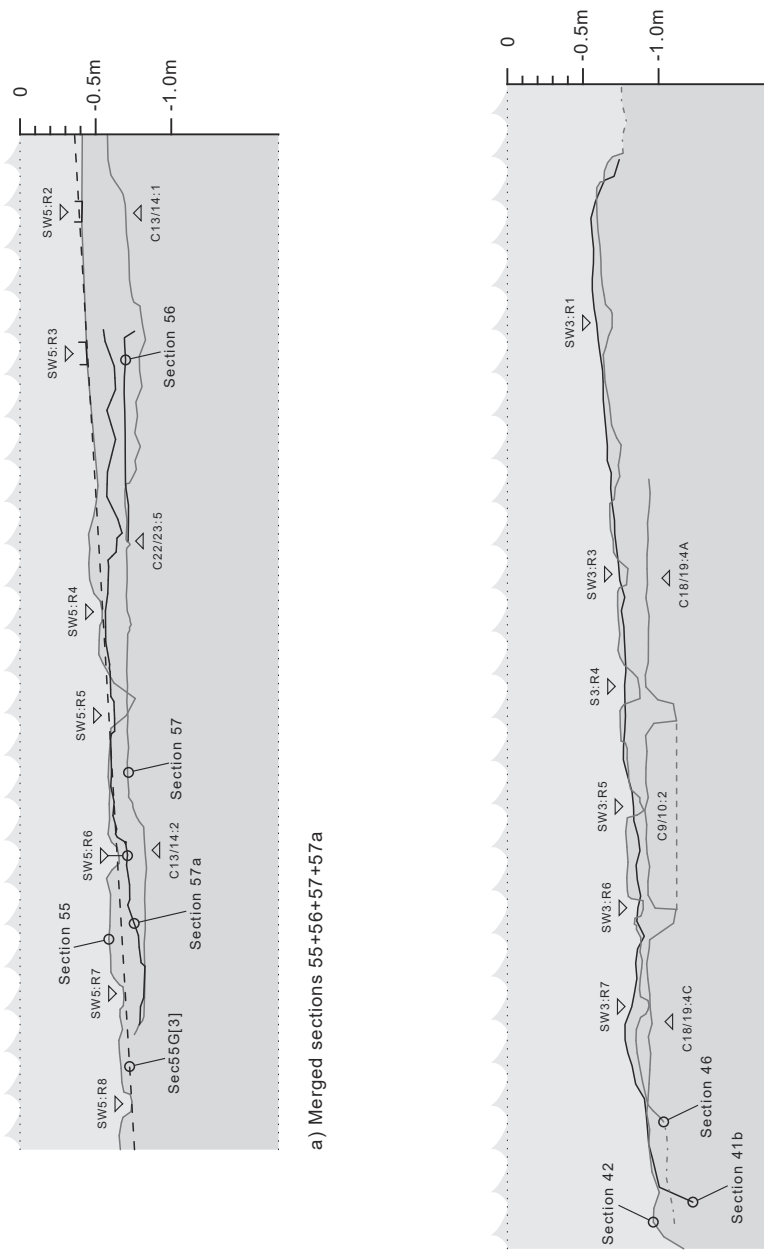

a) Merged sections 55+56+57+57a

b) Merged sections 41b+42+46



Fig. 228 Merged sections: a) 47+47[G2-T]+47[G3-B]+48+48[G2-T], and b) 41b+46

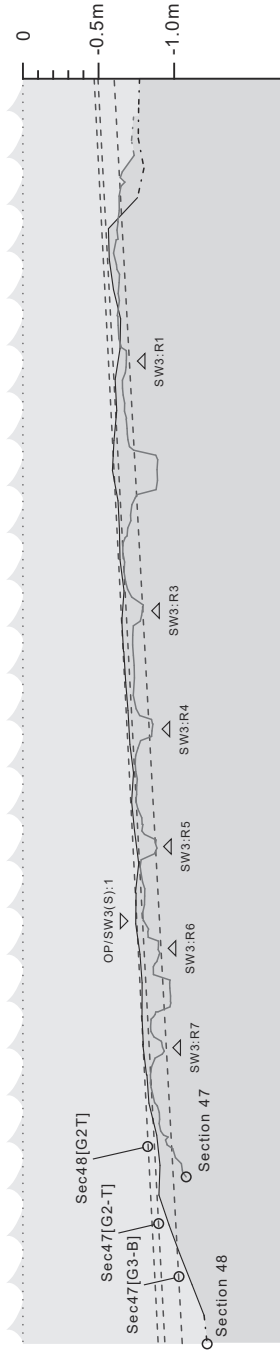

a) Merged sections 47+47[G2-T]+47[G3-B]+48+48[G2-T]

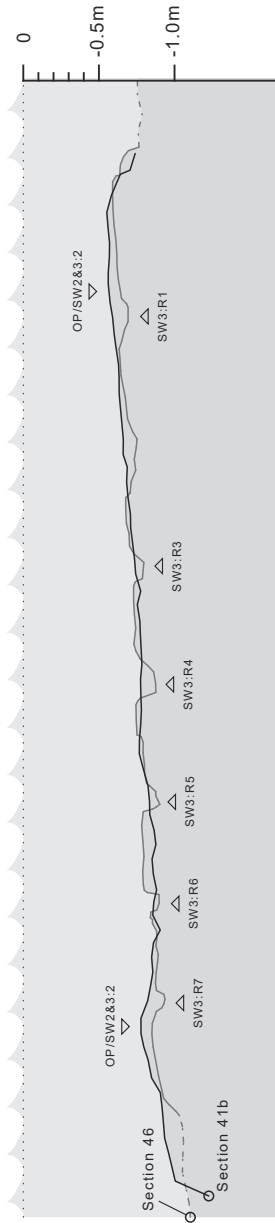

b) Merged sections 41b+46



Surveyor: Ellassen / Architect: Klejn-Christensen / Data: Lovén © ZHP 2011 1 : 50

Fig. 229 Merged sections: a) 30+31 (land), b) 35+36 (land)

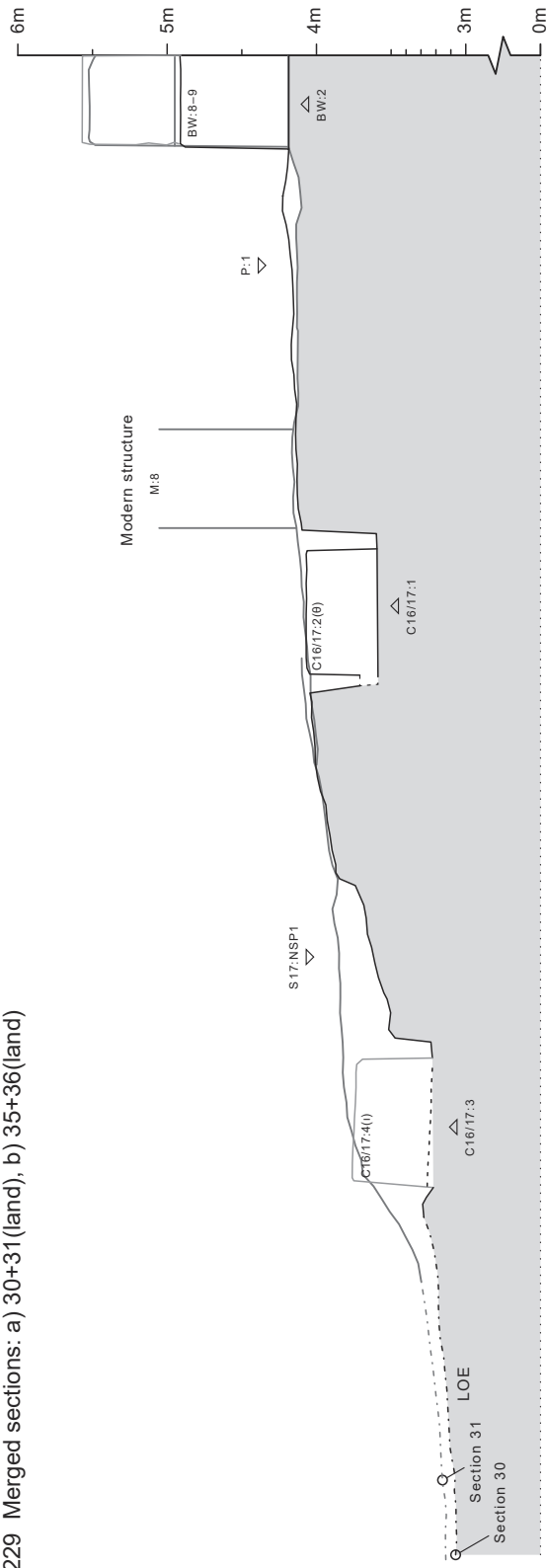

a) Merged sections 30+31 (land)

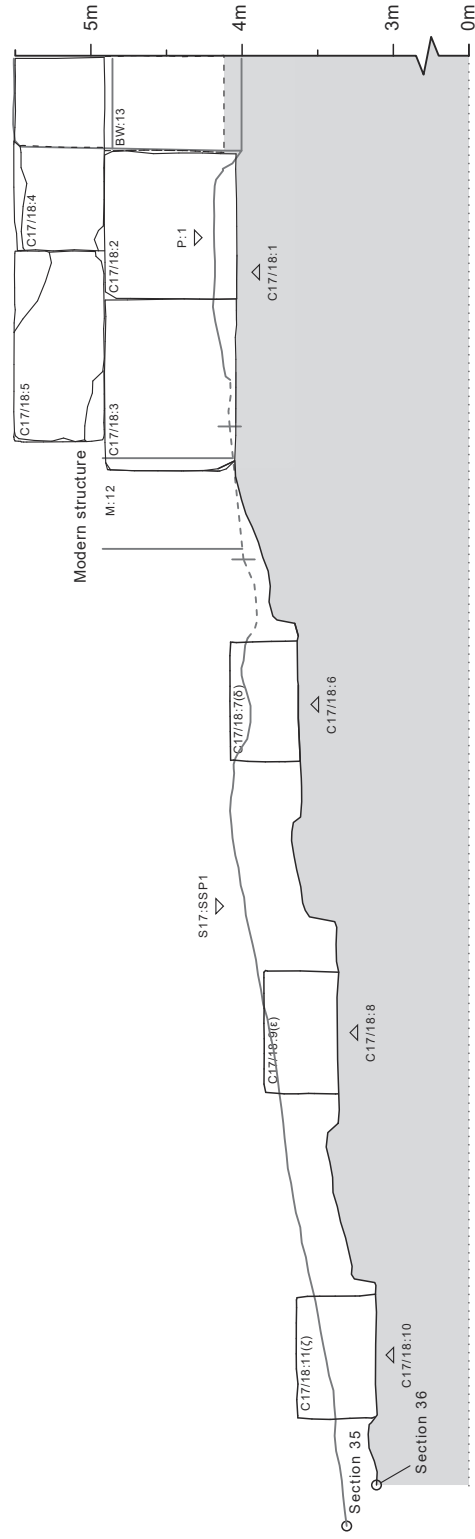

b) Merged sections 35+36 (land)



Surveyor: Eliassen / Architect: Klejn-Christensen / Data: Lovén © ZHP 2011 1 : 50

Fig. 230 Merged sections 24+30+36(land)

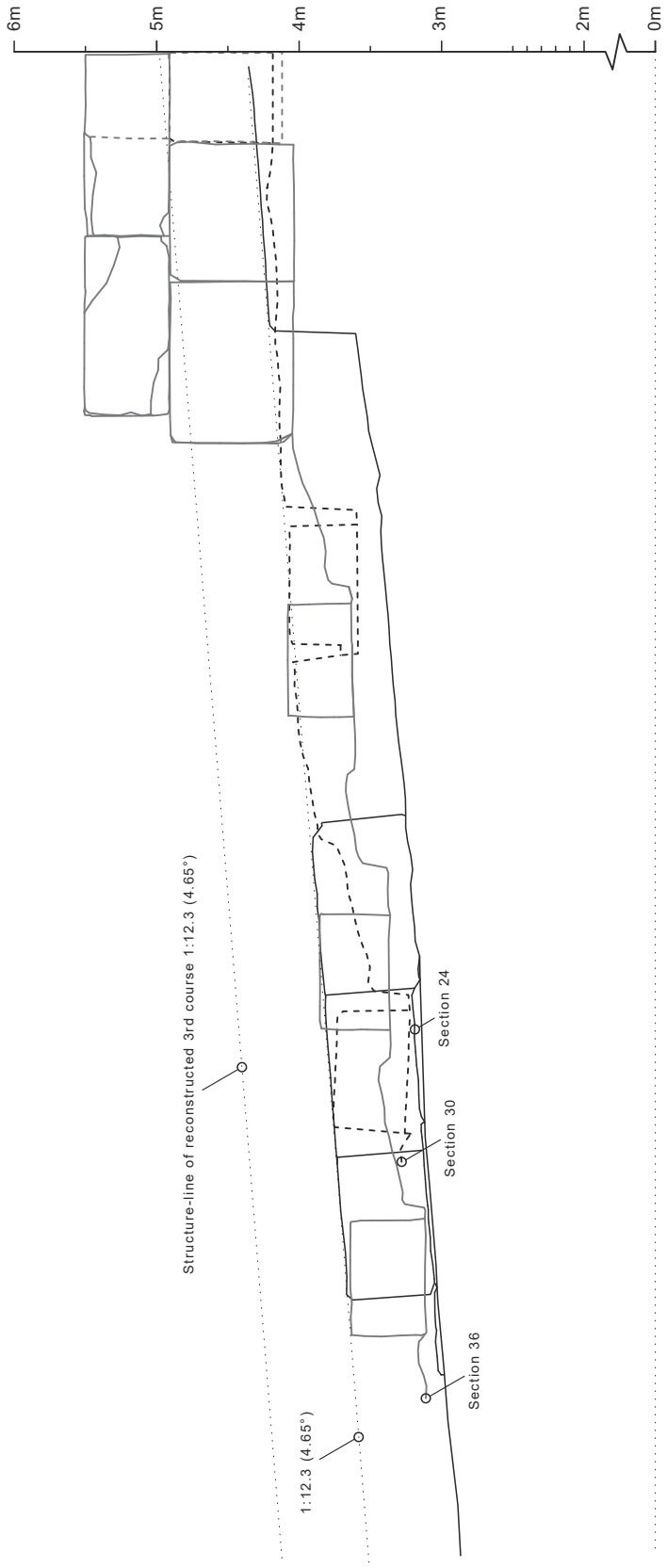

Merged sections 24+30+36(land)



Surveyor: Eliassen / Architect: Klejn-Christensen / Data: Lovén © ZHP 2011 1 : 50

Fig. 231 Interaxial spacings between colonnades C16/17(η), C17(η)/18(χ), C18(χ)/19(φ), W16/26(λ) and C26/27(?)

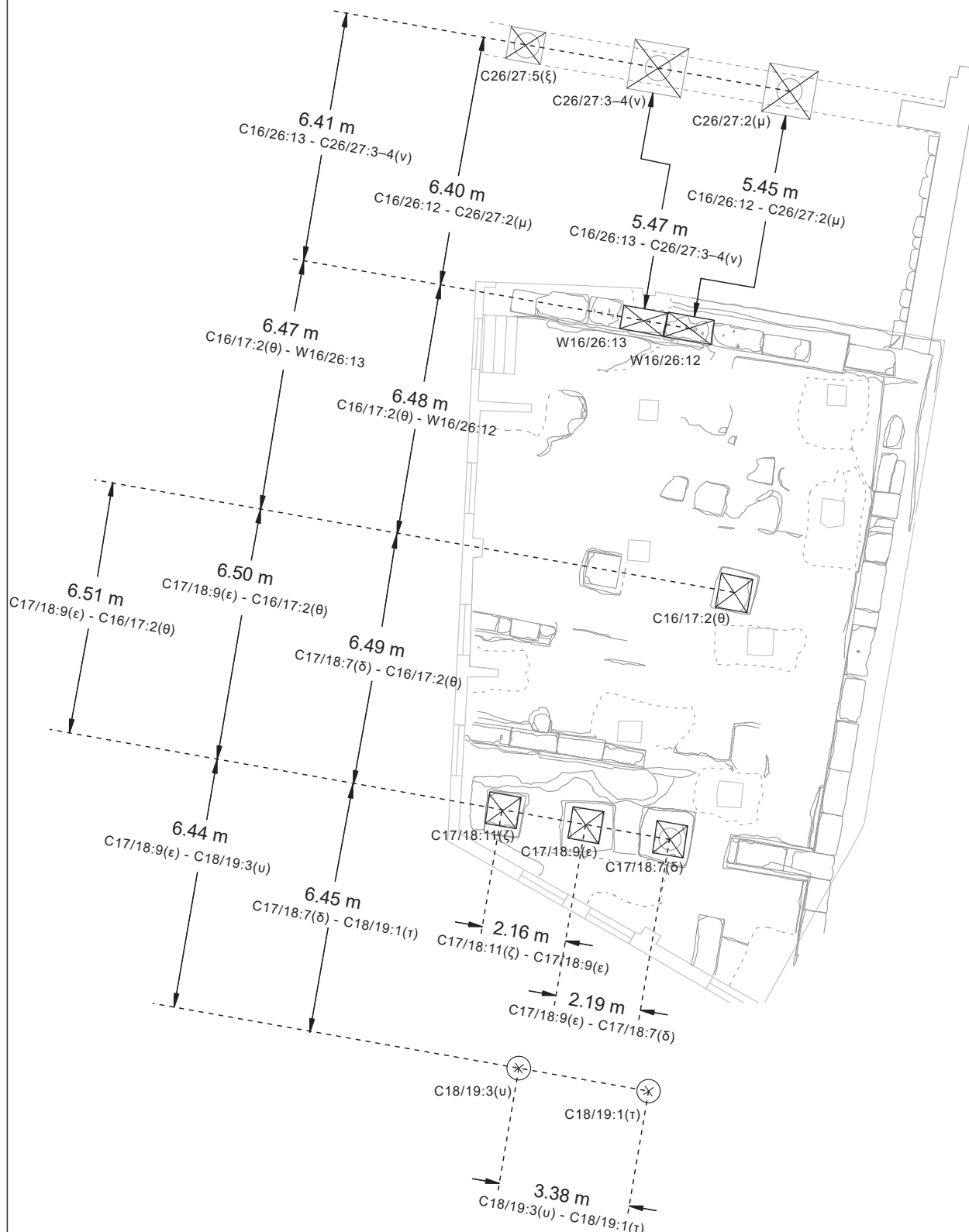

0 15m

Surveyor: Eliassen / Architect: Klejn-Christensen / Data: Lovén © ZHP 2011 1 : 150



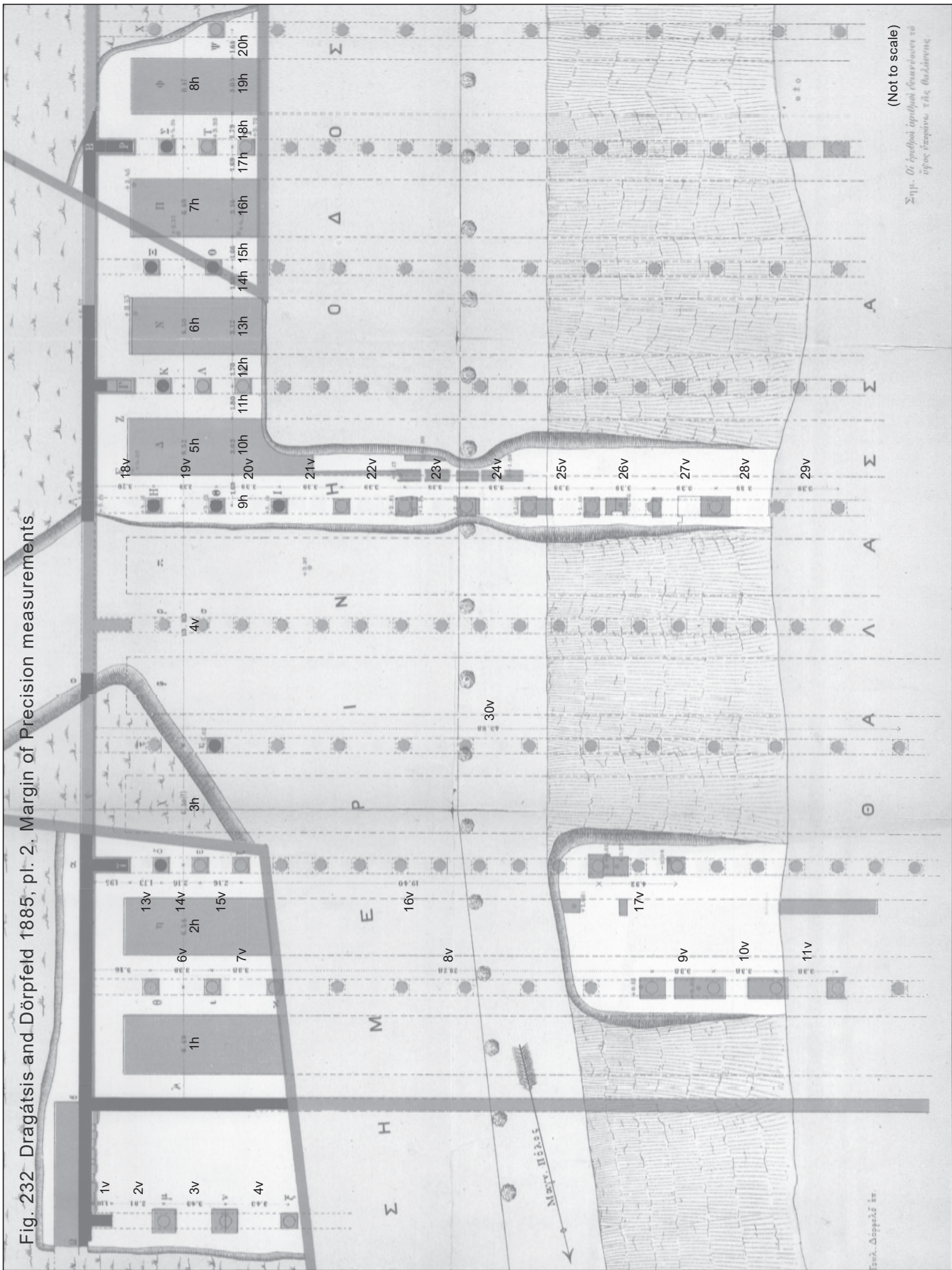
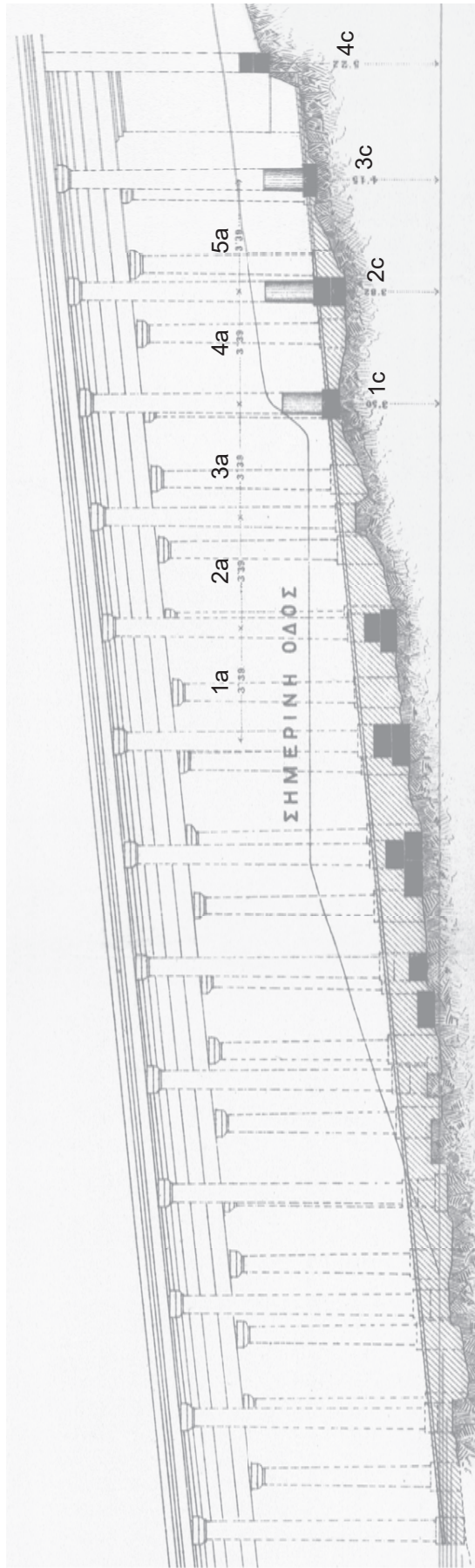
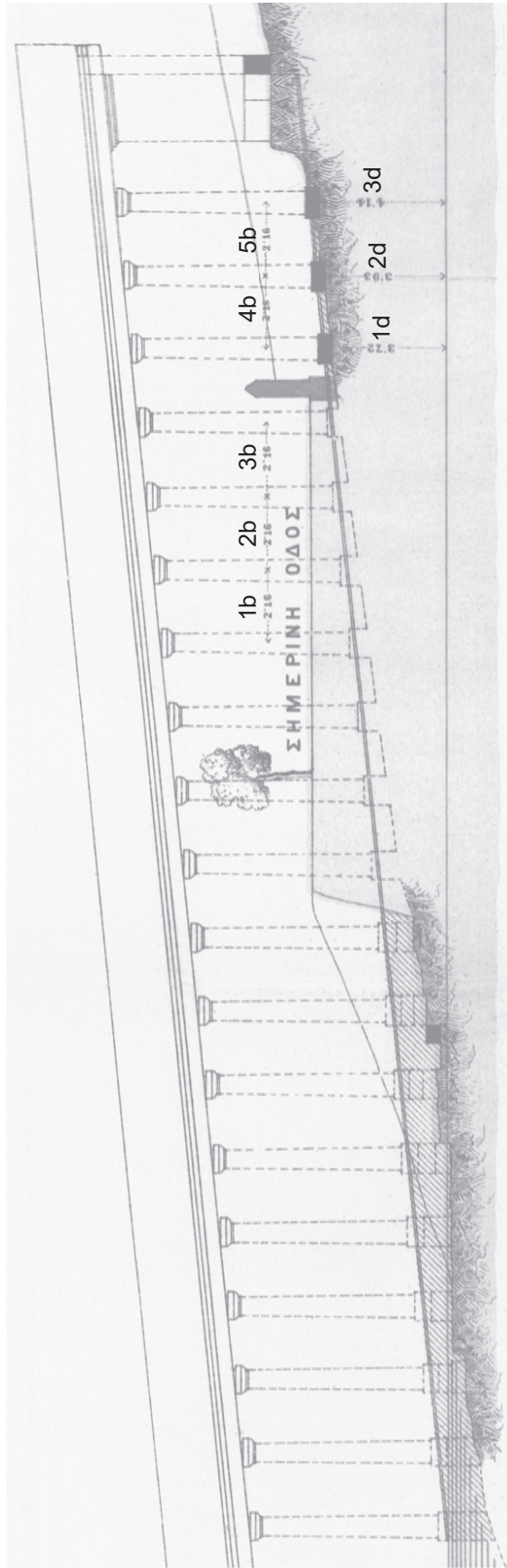

Fig. 233 Dragátsis and Dörpfeld 1885, pl. 3. Margin of Precision measurements:
 a) Colonnade dividing Shipsheds 20(π)/21(Δ), and b) Colonnade dividing Shipsheds 17(η)/18(X)



a) Colonnade dividing Shipsheds 20(π)/21(Δ)



b) Colonnade dividing Shipsheds 17(η)/18(X)

(Not to scale)

Fig. 234 Plan of the pit U:2 (Sector A)

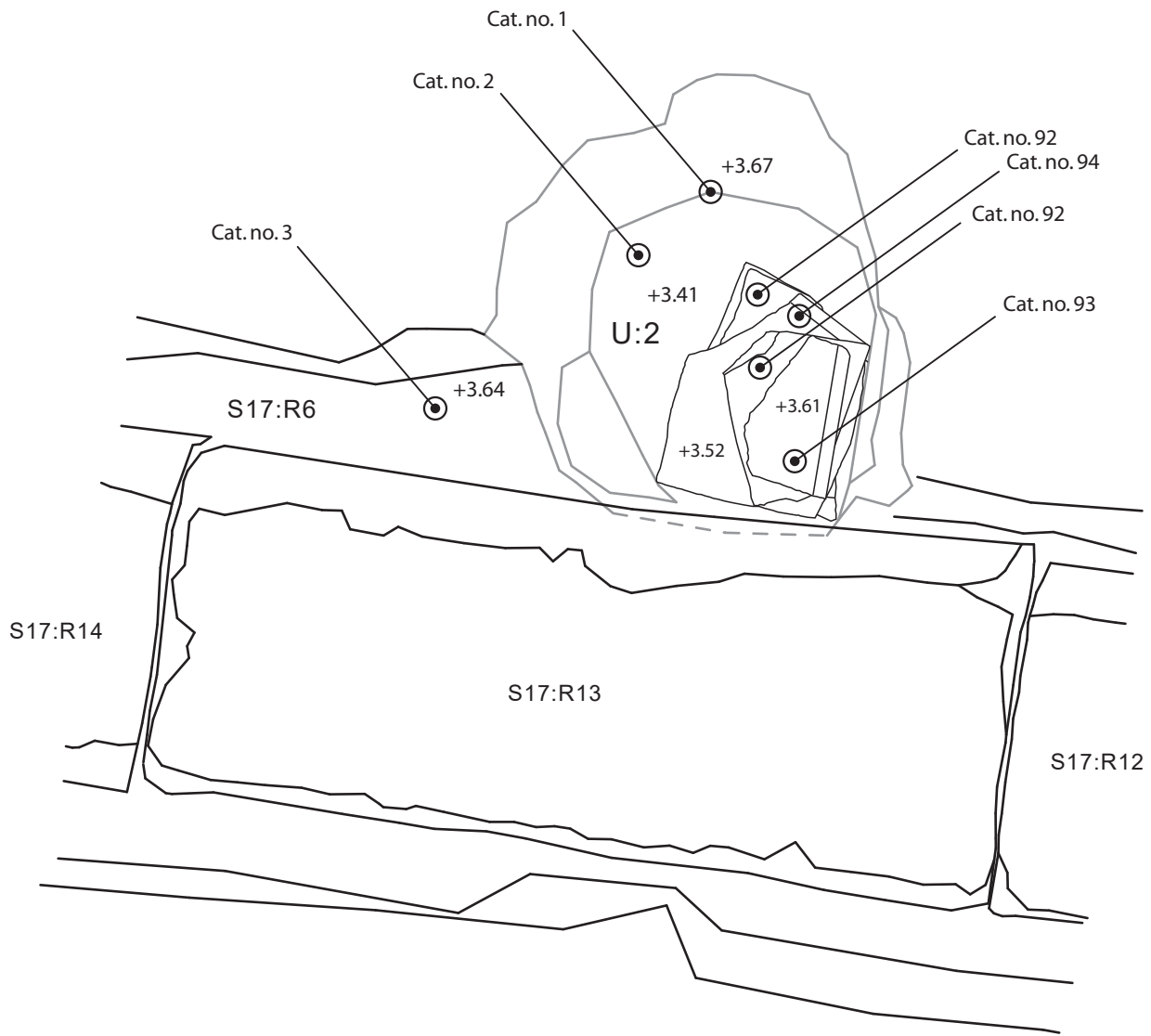

0 1m

Surveyor: S.R. Eliassen / Architect: B. Klejn-Christensen © ZHP 2011

1 : 10



Fig. 235 Reconstruction of a Corinthian pan tile. The borders of the pan tile are outlined and their measurements are listed. The total length and width, however, are hypothetical (the length 79.8 cm and the width 54.0 cm are used in the Phase 3 reconstruction)

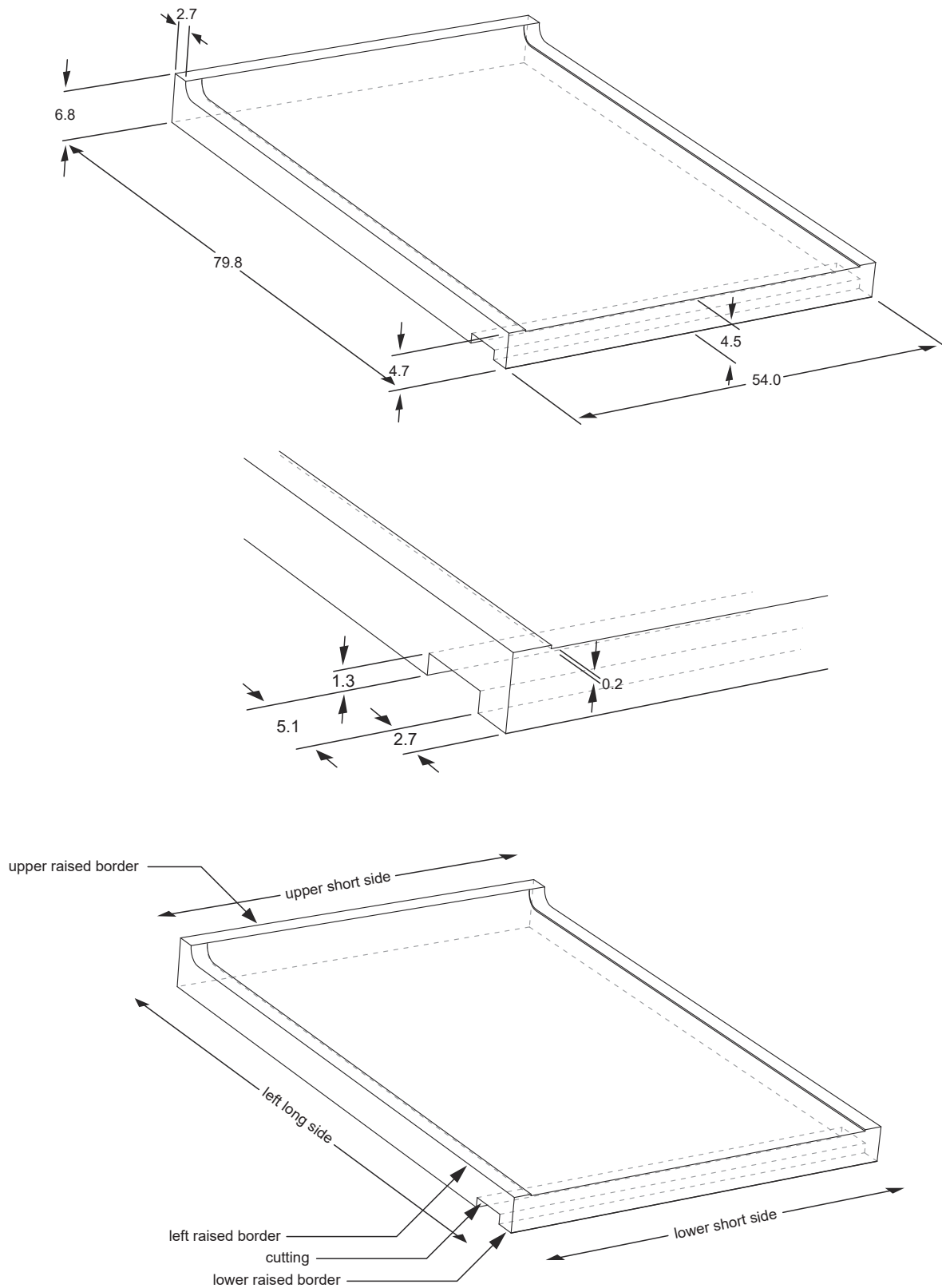
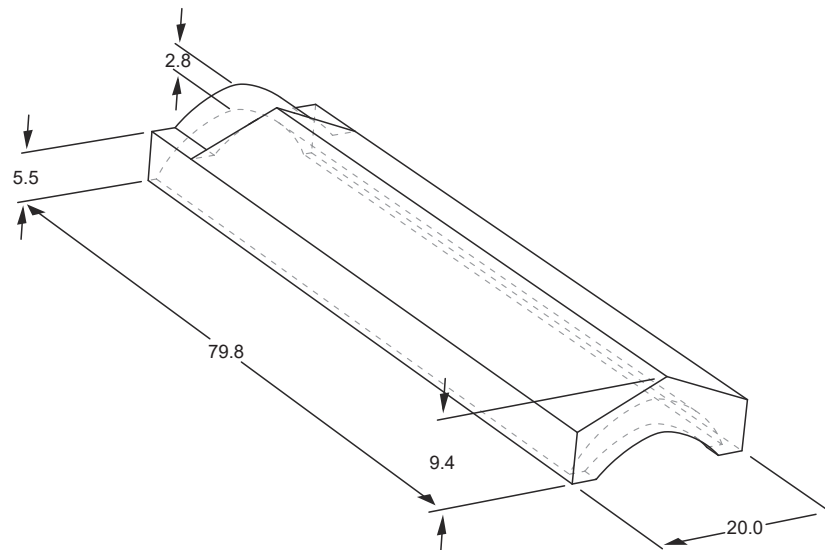

Fig. 236 Reconstruction of a Corinthian cover tile. The width is known; the cutting at the upper end and the length of the tile remain hypothetical



Architect: B. Klejn-Christensen / Data: M. Schaldemose © ZHP 2011

Fig. 237 Reconstruction of the tile components and their overlapping arrangement of the Phases 2 and 3 roofs of the Zea shipsheds

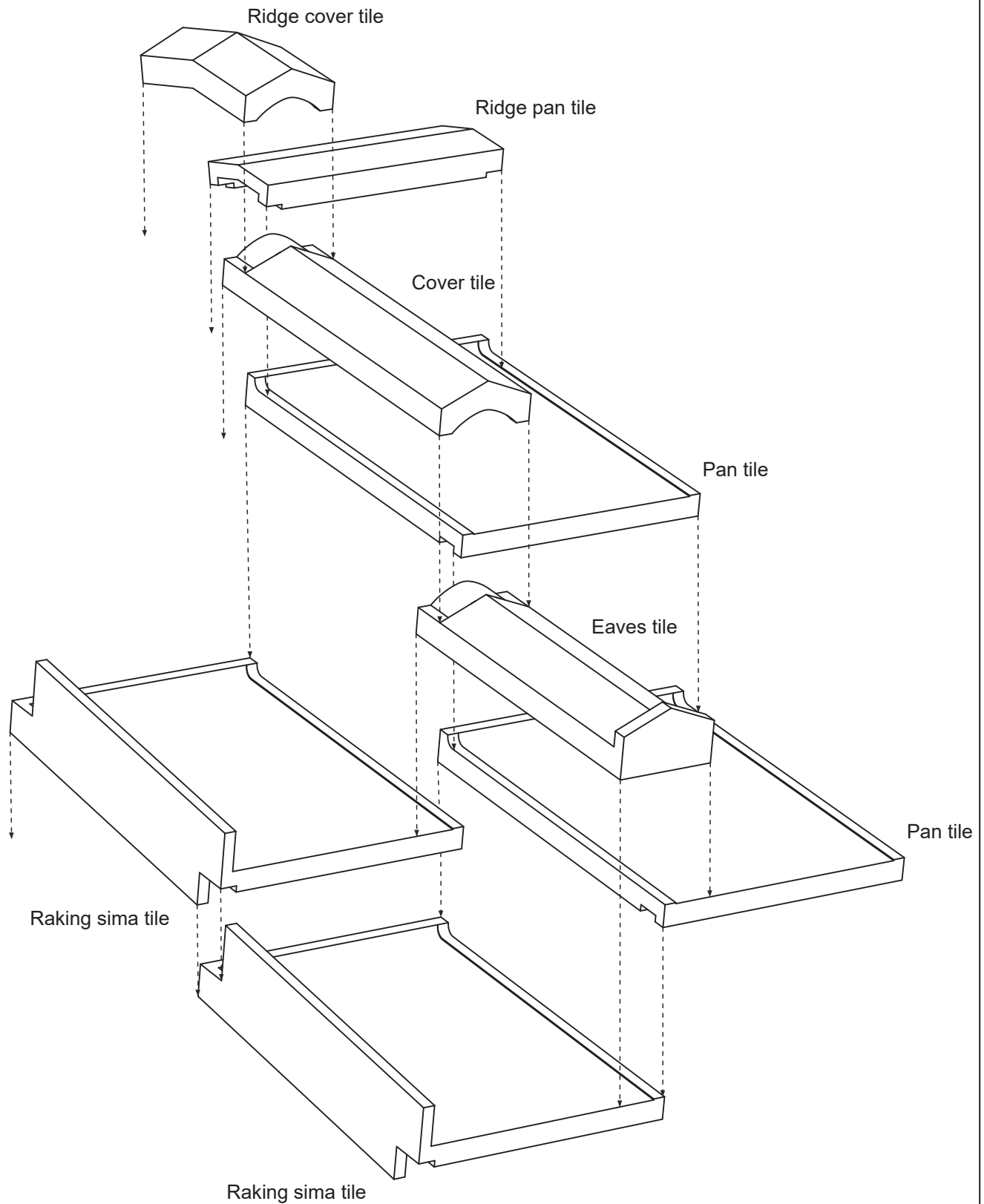
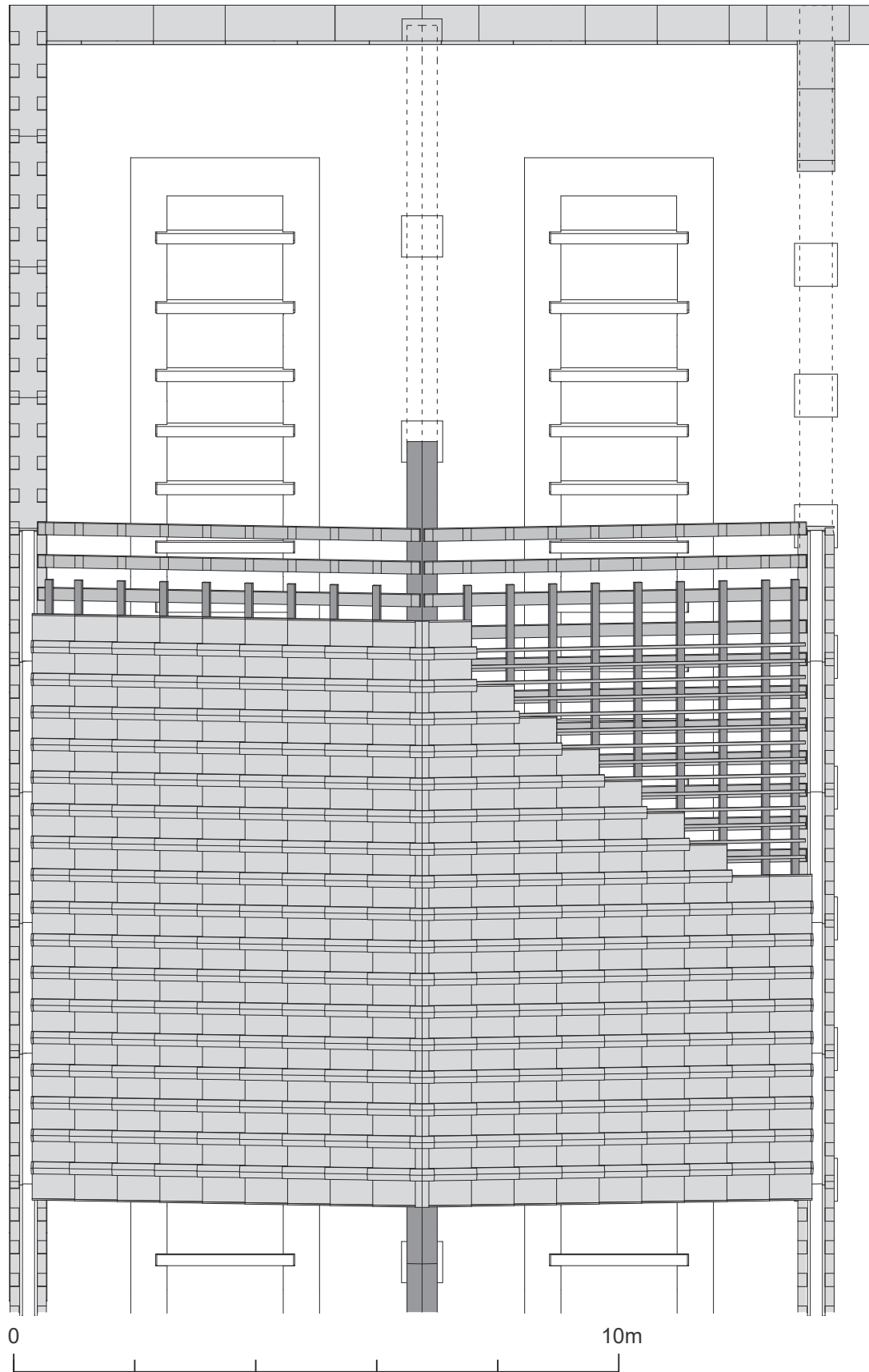

Fig. 238 Top view of the reconstructed roof of the Phase 3 shipsheds, showing the capitals, architrave, ridge beam, gutter, rafters, battens, sheathing and tiles



0

10m

Architect: Klejn-Christensen / Data: Schaldemose and Lovén © ZHP 2011

1 : 100

Fig. 239 Three-quarters view of the reconstructed roof of a section of the Phase 3 shipshed showing all the roof elements

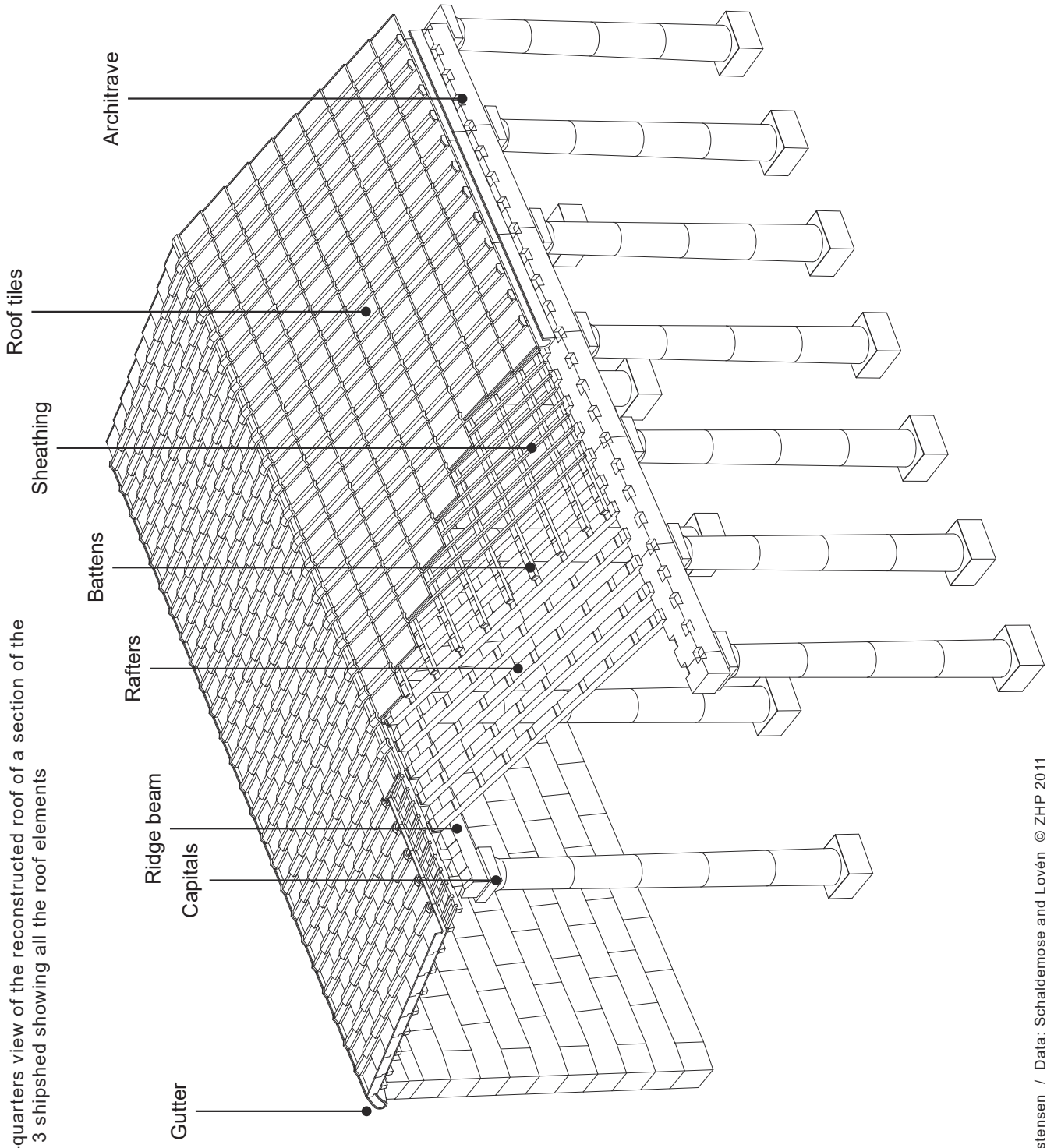

Architect: Klejn-Christensen / Data: Schaldemose and Lovén © ZHP 2011

Fig. 240 Artistic reconstruction of a *trireme* being hauled into a shipshed (Y. Nakas ©ZHP 2010)

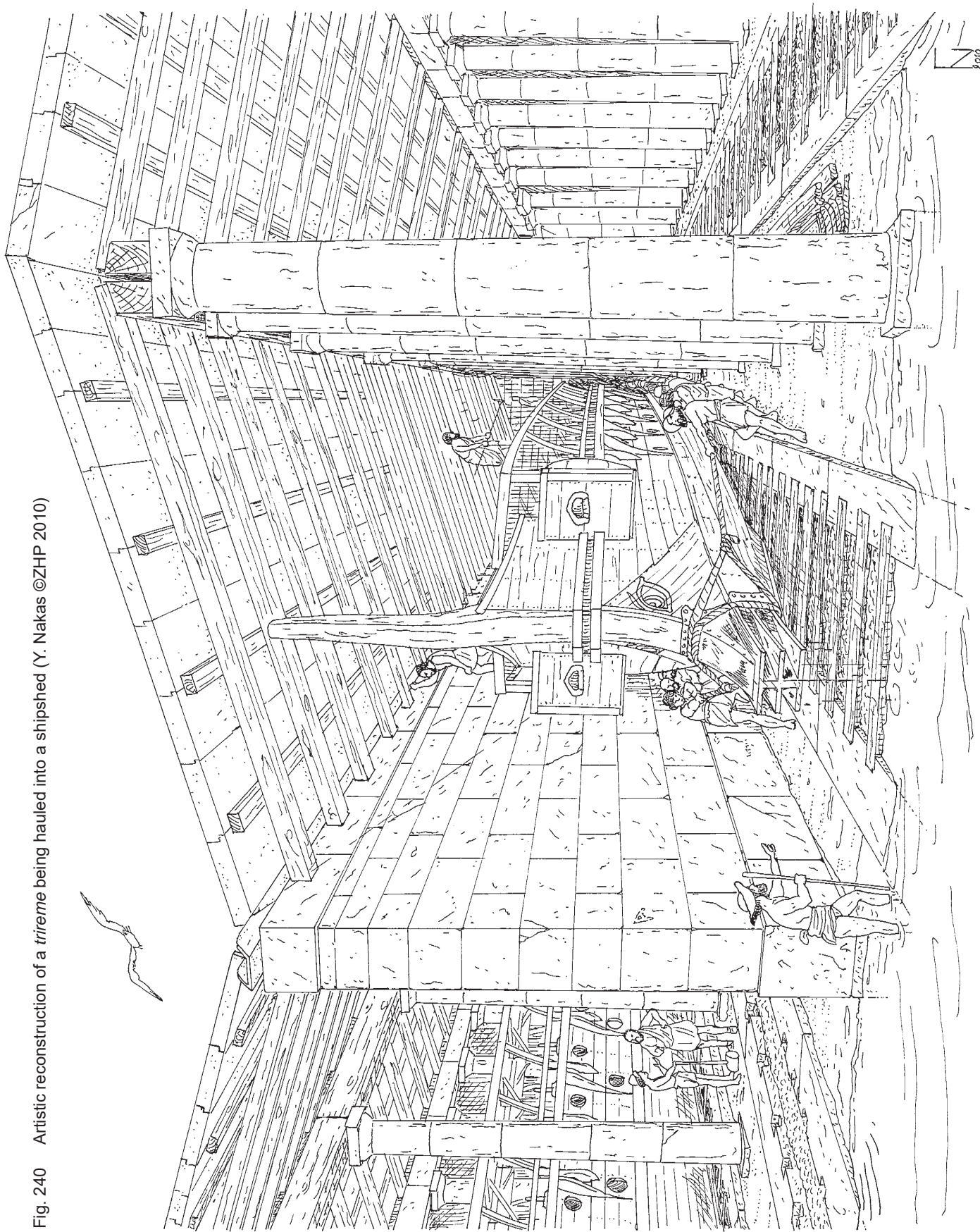

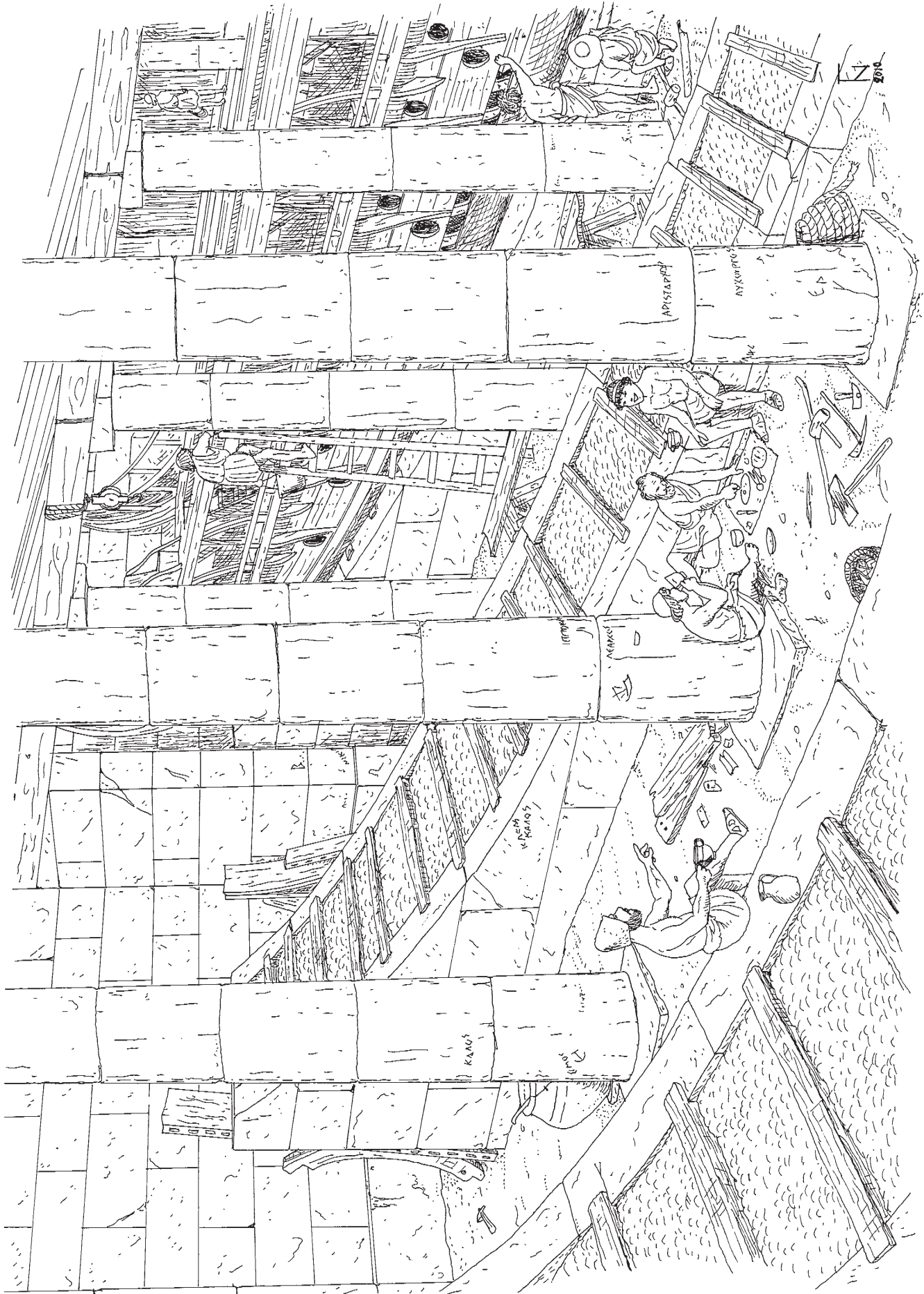

Fig. 241 Artistic reconstruction of the stern-supporting ramp section (Y. Nakas ©ZHP 2010)